

R E P O R T R E S U M E S

ED 013 853

UD 004 095

PUPIL, STAFF, AND EDUCATIONAL FACILITY CHARACTERISTICS
ASSOCIATED WITH PUBLIC LAW 89-10 TITLE I PROJECTS IN IOWA.
INTERIM REPORT, 1 JUNE 1966-31 MAY 1967.

BY- FOLEY, WALTER J.
IOWA UNIV., IOWA CITY

PUB DATE 67

CONTRACT OEC-3-6-001043-1514
EDRS PRICE MF-\$1.25 HC-\$11.52 288P.

DESCRIPTORS- *COMPENSATORY EDUCATION PROGRAMS, *PROGRAM
EVALUATION, *DISADVANTAGED YOUTH, PROFESSIONAL PERSONNEL,
*STATISTICAL ANALYSIS, COMPARATIVE TESTING, TESTS, TABLES
(DATA), SECONDARY EDUCATION, INDIVIDUAL CHARACTERISTICS,
ACHIEVEMENT, ATTENDANCE, ASPIRATION, ABILITY, PROGRAM
ADMINISTRATION, PROGRAM BUDGETING, SALARIES, SCHOOL SERVICES,
PERSONNEL, ELEMENTARY GRADES, ESEA TITLE 1, IOWA PUPIL
INVENTORY, IOWA TESTS OF EDUCATIONAL DEVELOPMENT, IOWA TESTS
OF BASIC SKILLS, IOWA

THIS DETAILED FOUR-PART REPORT ASSESSES THE FIRST YEAR
OF COMPENSATORY EDUCATION PROJECTS ESTABLISHED IN IOWA UNDER
TITLE I OF THE 1965 ELEMENTARY AND SECONDARY EDUCATION ACT.
OVER 95 PERCENT OF IOWA'S SCHOOL DISTRICTS, MANY OF THEM IN
RURAL AREAS, PARTICIPATED IN THE PROJECT. THE MOST
SIGNIFICANT SHORTCOMING OF THE LOCAL PROJECTS WAS THEIR LACK
OF INVOLVEMENT AT THE PRESCHOOL AND EARLY ELEMENTARY LEVELS.
DURING THE FIRST YEAR READING REMEDIATION WAS THE PRINCIPAL
OBJECTIVE OF MOST OF THE LOCAL PROJECTS, BUT IT IS HOPED THAT
IN THE SECOND YEAR THEY WILL PURSUE A GREATER VARIETY OF
PROGRAMS. THE 60 PROJECTS WHICH STATED CURRICULUM CHANGE AS A
MAJOR GOAL AVERAGED 6.06 CHANGES. THE SALARIES PAID TO
PROJECT ADMINISTRATORS AND TEACHERS WERE SLIGHTLY LOWER THAN
THOSE PAID TO THEIR NONPROJECT COUNTERPARTS. AS COMPARED WITH
A SAMPLE OF NONPROJECT PUPILS, TITLE I PUPILS HAD A LOWER
LEVEL OF ACHIEVEMENT, LOWER ASPIRATIONS AND EXPECTATIONS, AND
POORER SCHOOL ATTENDANCE. THE CHIEF INSTRUMENTS USED TO
COMPARE THESE TWO GROUPS WERE THE IOWA TESTS OF EDUCATIONAL
DEVELOPMENT, THE IOWA TESTS OF BASIC SKILLS, AND THE IOWA
PUPIL INVENTORY. AN ATTEMPT WAS ALSO MADE TO ANALYZE THE
INTERACTIONS OF PUPILS, TEACHERS, AND EDUCATIONAL PROGRAMS IN
TERMS OF ACHIEVEMENT, ATTENDANCE, AND CHANGE IN ASPIRATION,
TO FIND SIGNIFICANT PREDICTORS TO EVALUATE TITLE I PROJECTS.
THE COMPLETE ANALYSIS OF THIS INFORMATION WILL APPEAR IN THE
FINAL REPORT. (LB)

ED013853

#17
TITLE I EVALUATION

OEC-3-6-001043-1514

U.S. DEPARTMENT OF HEALTH, EDUCATION & WELFARE
OFFICE OF EDUCATION

must E

UD004095

THIS DOCUMENT HAS BEEN REPRODUCED EXACTLY AS RECEIVED FROM THE PERSON OR ORGANIZATION ORIGINATING IT. POINTS OF VIEW OR OPINIONS STATED DO NOT NECESSARILY REPRESENT OFFICIAL OFFICE OF EDUCATION POSITION OR POLICY.

INTERIM REPORT

CONTRACT NO. OEC-3-6-001043-1514

PERIOD COVERED: JUNE 1, 1966, THROUGH MAY 31, 1967

NAME OF INSTITUTION: THE UNIVERSITY OF IOWA (IOWA EDUCATIONAL INFORMATION CENTER)

TITLE OF PROJECT: PUPIL, STAFF, AND EDUCATIONAL FACILITY CHARACTERISTICS ASSOCIATED WITH PUBLIC LAW 89-10 TITLE I PROJECTS IN IOWA

PROJECT DIRECTOR: WALTER J. FOLEY

TABLE OF CONTENTS

	Page
Foreword	1
Introduction	2
PART I	8
The Administrative Context	8
PART II	33
Administrative Communications	33
Reference Key	44
Administrative Project Information by Objective Title	54
Ability, Achievement and Other Factor Codes	81
PART III	141
Pupil Inventory Item Analysis	153
A Comparison of Responses of Title I Vs. A Sample of Other Pupils to Inventory Items	157
The Iowa Tests of Educational Development	184
Iowa Tests of Basic Skills	198
PART IV	215
Iowa Pupil Inventory Comparisons	217
PART V	281
Summary	281
APPENDIX A	
APPENDIX B	
APPENDIX C	
APPENDIX D	

Miss 9

Foreword

This interim report represents our first effort to meet the commitments of the contracted agreement. When examining the information presented, it must be remembered that the Title I programs described were only in operation one semester. Further, the limitations of time and sequencing encountered in developing each part of the report have been detailed in each section.

This interim report is also written to provide a preview of the data analysis that will be included in the final report of July, 1968. At that time inferences related to the assessment of the impact of the legislation can be better made at a comparative level. For example, the elementary portion of the Iowa Testing Program was administered in the spring, before the actual programs began, and represents what may be thought of as a premeasure on these pupils. The final report will be more conducive to impact type comparisons for these pupils as their retesting will, it is expected, reflect change.

Also, it should be pointed out that wherever available data made it possible, a comparison sample of pupils not designated as involved or identified in Title I programs has been used for comparison purposes. For the most part, these comparisons clearly indicate the discrepancies in level of functioning between the groups.

Introduction

Title I of the 1965 Elementary and Secondary Education Act was designed to provide increased educational opportunities for children and youth who are socially, economically, or environmentally deprived. Title I was designed to meet the specific needs of a specified group through the existing educational structure. It was, in effect, a vehicle for the provision of compensating educational opportunities coupled with an evaluation to assess the extent that pupils profit from these types of experiences. The assessment of the effective translation of this mandate into action programs of compensatory education is the subject of this interim evaluation report. In the most general of terms, this report is aimed at an initial assessment of the impact of Title I of the Elementary and Secondary Act in the State of Iowa.

Method of Evaluation

The magnitude of the program in Iowa can be comprehended, in a sense, by the fact that during the fiscal year 1966 \$15, 445, 609 of Title I monies were expended. This figure represented approximately 4.2% of the total statewide public school expenditures for the 1965-66 school year. In an attempt to effectively manage the evaluation project, a series of organizational decisions were made. These decisions are described here in the hope that they will help the reader in understanding the approach and provide a frame reference for this interim report.

First, in order to bring the project into some semblance of a manageable perspective, the legislation was thought of in terms of the organizational structure which administered the program. This, then, represented the State Department of Public Instruction context as the vehicle for the implementation of the legislation. It was felt that the evaluation of the outcomes of the program would be enhanced by an understanding of their relationship to the administrative structure; if you will, the products of the program as related to the machinery which administered the program.

Stated another way, the 625 participant educational agencies had certain common requirements, or constraints, placed upon them by the State Department of Public Instruction as the administrative office of the legislation at the state level, and perhaps unique constraints in that each local program had to be locally managed. The State Department produced the guidelines, approved the proposals and monitored the various project activities of the local educational agencies (hereinafter referred to as LEA's). The local agencies provided their individual administrative structure.

The internal context, i.e., educational processes and accomplishments of the funded projects established, it was felt could be better understood when these external factors (state and local organizational constraints) were interwoven into the evaluation fabric.

We then had clarified our thinking to the point of our first

dichotomy. The two dimensions, termed the internal and external, formed the first major axes of our evaluation strategy and are shown graphically in Figure 1.

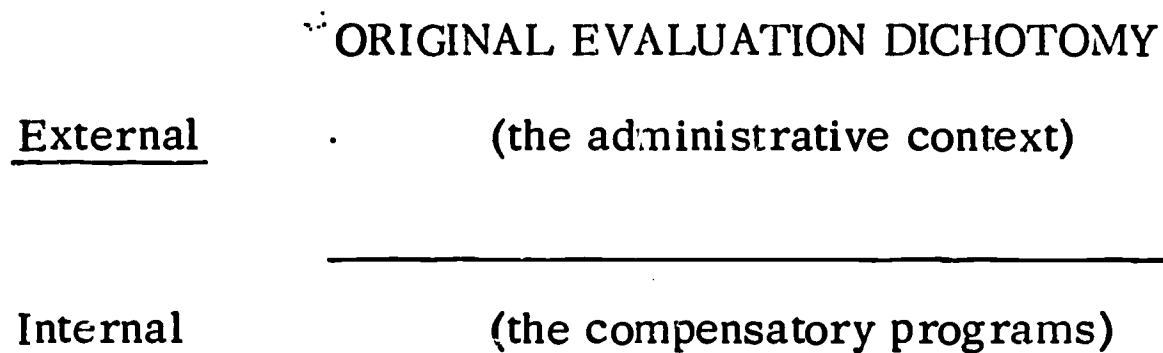

Figure 1.

Next, a decision was made concerning the organization and classification of available information for a better understanding of the logically possible relationships inherent in the study. The problem in the available information area had to do with the descriptive versus quantitative nature of the data sources; the relationship between the two types of data; the relationship of the data to the goals of the projects within the existing restrictions; and finally, the conclusions that were to be drawn from this study.

In order to conceptualize these data sources and relationships, the original external-internal axis was further classified into a qualitative-quantitative categoric axis. The resulting evaluation strategy took the form of two manageable yet intertwined classification systems which formed the crossbreak shown as Figure 2.

THE EVALUATION STRATEGY MODEL

	Quantitative	Qualitative
	(administrative context)	(administrative communications)
	PART I	PART II
	examples:	examples:
External	<ol style="list-style-type: none"> 1. funding 2. project personnel 3. positions created 4. target population 	<ol style="list-style-type: none"> 1. objectives 2. reports and communications
	(compensatory programs)	(compensatory program outcomes)
	PART III	PART IV
	examples:	examples:
Internal	<ol style="list-style-type: none"> 1. teacher information 2. pupil information 3. program information 4. test information 	Selected relationships from Parts I, II, and III

Figure 2.

The relationships of information in each cell when viewed in terms of the rationale that motivated Title I legislation then become available for decision making. The multiple criteria for outcome evaluations, i.e., standards of excellence, achievement, and the judgments of both participants and experts of the program areas, necessitated the need for multiple sources and levels of information. Within the context of the model, the

evaluation report which follows will consist of four parts.

Part I deals with the context of the legislation, the funds made available and how they were spent, the organizational structure the legislation created and the programs established. The information presented in this section comes from the required state evaluation report and information gathered by the Iowa Educational Information Center. Several relevant classifications of this information are presented.

Part II describes the target population in terms of project objectives, personnel employment in terms of project type and other professional services offered.

Part III describes the pupils, the teachers who were involved in the programs, the effect of the legislation on the curriculum, and the special services provided to pupils. The information presented in this section is based upon the data collection activities of the Iowa Educational Information Center and the original applications of the local educational program.

Part IV summarizes the interactions of pupils, teachers and educational programs in terms of achievement, attendance, and change in aspiration. This section of the report represents our first attempts at relating relevant variables. In a sense, this section may be thought of as our initial efforts to find relationships, significant predictors, and evaluative elements.

The total report presents the more persuasive evaluatory statements

that can be generalized. Also, the expectations of the evaluators concerning the appearance and format of the 1968 final report may be found in this interim document.

PART I

THE ADMINISTRATIVE CONTEXT

The emphasis of Title I legislation was on individual children through compensatory educational practices. No doubt, when the sheer number of cases involved are examined alongside the financial data, Title I in the first year of operation did have a tremendous impact on the educational practices in the State of Iowa.

In this section of the report we examine the grants that were funded through Title I, the breakdown of what happened to the money involved and the project organizational structure of those projects funded.

The first portion of the report has been presented in terms of the five Standard Metropolitan Statistical Areas (hereafter referred to as SMSA). This, in response to the Office of Education's request, allowed the state to employ a classification scheme based on Bureau of Budget definitions. The key to this system of SMSA as defined by the Bureau of the Budget follows:

CLASSIFICATION A includes the largest "core city" in the SMSA. If the area is composed of "twin cities" or "tri-city" areas, such as Minneapolis-St. Paul, Classification A should represent all the large cities as the SMSA.

CLASSIFICATION B includes all secondary cities within the SMSA that have populations of 50,000 or more. Also included in Classification B should be "older secondary cities" within the SMSA which have populations of less than 50,000. The "older secondary city" is characterized by a high incidence of low-income families, antiquated and high density housing, low mobility of inhabitants, or other traits which the states may use as criteria. States are urged to use their judgment in identifying and classifying "older secondary cities."

CLASSIFICATION C includes all other rural or urban areas within the SMSA which have a population of fewer than 50,000. These can be either incorporated or unincorporated areas.

CLASSIFICATION D includes all local educational agencies serving school districts in urban areas outside the SMSA which have populations between 2,500 and 49,999.

CLASSIFICATION E includes all local educational agencies serving school districts in rural areas outside the SMSA which have populations below 2,500.

Before proceeding into the analysis, it is well to keep in mind the composition of the population of the State of Iowa. First, under Classification A which includes the "core cities" Iowa has six school districts represented at this level. Under Classification B

which includes the secondary cities of 50,000 or more and the older secondary cities which have populations of less than 50,000, Iowa is represented by two such school districts.

The bulk of the school districts in the State of Iowa are included in Classification E which serves school districts in rural areas outside Standard Metropolitan Statistical Areas which have populations below 2,500. To this extent, the classification of the projects reflects the state but perhaps more clearly reflects the rural nature of the state within the United States.

Basic Grants

This portion of the report dealt with the monies granted to the local school districts in relation to how the funds were divided among preschool, elementary, secondary and combined elementary/secondary school districts.

Table I shows the maximum basic grant by SMSA level within the school district. The largest grants were given the six school districts in SMSA Classification A. The mean amount of the grant for this group was \$323,639. The mean basic grant for the 307 school districts in SMSA level E was \$30,661. The range in mean amount of basic grant funds was approximately ten to one with the largest to SMSA level A and the smallest grant to SMSA level E. But when examined in terms of actual dollars expended, SMSA level E received the largest portion of the total monies.

TABLE I

Maximum Basic Grant by SMSA Level / District

	<u>M</u>	<u>SD</u>	<u>N</u>
A	323, 639	260, 040	6
B	81, 350	39, 927	2
C	38, 205	52, 187	27
D	64, 762	85, 135	85
E	30, 661	26, 289	<u>307</u>
			427

In turning to where the money was spent by level of pupil involved, the SMSA levels supporting preschool projects were the levels C, D, and E. Clearly, these were the more rural areas of the state. The actual distribution of funds for preschool projects is shown in Table II.

TABLE II

Preschool Funds Approved by SMSA Level / District

	<u>M</u>	<u>SD</u>	<u>N</u>
A	-	-	-
B	-	-	-
C	10, 634	4, 148	2
D	8, 167	7, 333	16
E	7, 102	9, 264	<u>17</u>
			35

The table compared the preschool funds approved by SMSA level and the number of districts at each level. The striking thing about this table was that of the 427 districts included in these analyses, only 35 submitted preschool projects that were approved at the state level during the first year of program operation.

Turning to the elementary school Title I projects approved by SMSA level, Table III showed that, in terms of frequency, projects at this level were most frequently funded. In all, 144 districts of the 427 districts in the analysis applied for elementary project funding.

TABLE III

Elementary Funds Approved by SMSA Level / District

	<u>M</u>	<u>SD</u>	<u>N</u>
A	158,757	96,233	5
B	65,754	0	1
C	10,562	6,802	12
D	19,736	19,222	41
E	11,696	9,830	<u>85</u>
			144

SMSA level A had 5 district applications with a mean expenditure of \$158,757 per district. The smallest mean appropriation, that of \$10,562, occurred at SMSA level C where 12 districts were represented. Most frequently, SMSA level E applied for and received Title I funds for elementary projects. For the 85 districts at SMSA level E the mean appropriation was \$11,696.

The secondary Title I projects approved by SMSA level, included as Table IV, showed that 137 districts had secondary projects approved. Again the highest mean appropriation per project, that of \$97,982, occurred at SMSA level A where 4 districts were represented. The most frequent type district requesting funds at the secondary level was also SMSA level E where 79 districts had a mean appropriation of \$12,743 per project. The other project approved for SMSA level B occurred at the secondary level and was for \$53,464.

TABLE IV

Secondary Funds Approved by SMSA Level / District

	<u>M</u>	<u>SD</u>	<u>N</u>
A	97,982	128,978	4
B	53,464	0	1
C	10,263	6,425	8
D	15,437	11,011	45
E	12,743	10,507	<u>79</u>
			137

The combined elementary/secondary districts granted funds under Title I are shown in Table V. Each of the SMSA levels is represented. Significantly, the majority of the projects had representation in the combined district funds category.

TABLE V

Combination (elementary and secondary) funds Approved by SMSA Level / District

	<u>M</u>	<u>SD</u>	<u>N</u>
A	142,700	64,896	5
B	41,264	0	1
C	35,687	49,744	18
D	40,389	25,896	68
E	23,058	15,983	<u>261</u>
			353

A total of 353 of the 427 total districts submitted projects which were approved under this category. Again SMSA level A received the largest mean appropriation for their five districts. The smallest appropriation in terms of mean dollar amount was \$23,058 for the 261 districts in SMSA level E. But, again in terms of sheer dollar amount while SMSA level E received the smallest mean appropriation, the number of districts in this category makes the actual dollar appropriation far greater than that received by any other SMSA category.

Instructional Cost

The appropriations under Title I gained another dimension of meaning when transferred into instructional cost figures. This section of Part I dealt with the analysis of instructional costs and has been further subdivided into supporting services, salaries, in-service training costs,

and a category labeled other costs which grouped small non-definable classifications.

First, the instructional costs by SMSA level were shown as Table VI. The classification for this table and for the remainder of the tables in this section is on a project basis. This means, for example, that while only five districts are represented by SMSA level A, 52 projects submitted data within these five districts on the instructional costs involved in the program. It was felt that a project level break out of data would be most meaningful for these data.

TABLE VI

Instructional Costs by SMSA Level/Project

	<u>M</u>	<u>SD</u>	<u>N</u>
A	31,152	41,098	52
B	28,782	8,084	5
C	16,900	31,841	43
D	15,276	14,760	211
E	12,703	10,963	<u>505</u>
			816

Table VI showed that the mean dollar expenditure for the 52 projects in the category SMSA level A was \$31,152 in instructional costs. At SMSA level B the five projects under this classification had a mean instructional cost of \$28,782. The mean expenditure for the 43 projects in SMSA level C was \$16,900 while \$15,726 was the

mean instructional cost for the 211 projects in SMSA level D. In contrast, SMSA level E included more projects than all other SMSA levels combined with a total of 505 projects submitting information on instructional costs. The mean dollar amount for each of these projects was \$12,703, again showing that the mean amount while smallest of the five categories represented by sheer volume the largest expenditure of funds at any SMSA level in the state.

Salaries shown in Table VII represented the largest dollar expenditure as a proportion of instructional costs. The breakdown shown in Table VII was by SMSA level across projects submitting data on salaries paid. The largest expenditure for salary occurred at SMSA level B with a mean of \$21,935 for the five projects reported in this category.

TABLE VII

Salaries by SMSA Level / Project

	<u>M</u>	<u>SD</u>	<u>N</u>
A	14,412	21,395	61
B	21,935	5,103	5
C	8,057	8,393	48
D	7,920	8,004	243
E	5,179	4,874	<u>572</u>
			929

A word of explanation is necessary as to why this figure may be misleading. The five projects showed a mean salary figure but this figure does not give any indication of the number of staff members involved. In other words, one should not come to the conclusion that a particular person received a mean salary of \$21, 935 but that the project spent a mean of \$21, 935 for salaries. Perhaps the best interpretation of this table is in terms of the size of the project. For example, SMSA level E showed 572 projects with a mean salary expenditure of \$5, 179. Restated, the projects in this SMSA tended to be smaller, single teacher and/or single person projects; whereas, the projects showing a larger mean expenditure for salaries tended to be multi-teacher and/or multi-person projects.

In order to make these first salary figures clearer, they are divided into the addition of teachers, the addition of administrative support and the addition of consultant support for the projects in the tables which follow Table VII.

Table VIII described the number of teacher additions by SMSA level across projects. As one would expect the mean number of teacher additions was greatest for SMSA level A with 7 teacher additions being made per project. SMSA level E had a mean of 3 additions per project. These figures tend to reinforce the idea that the larger multi-classroom projects were attempted by the metropolitan areas while the rural areas of necessity concentrated on smaller projects. Again, one should notice

that over half or 485 of the 790 projects classified were in rural areas. ¹⁸

TABLE VIII

Number of Teacher Additions by SMSA Level / Project

	<u>M</u>	<u>SD</u>	<u>N</u>
A	7	15	50
B	4	1	5
C	4	5	41
D	4	5	209
E	3	3	<u>485</u>
			790

Turning to the number of administrative additions, Table IX stressed the mean administrative additions across SMSA by projects. The most striking feature of this table was the almost uniform mean number of positions created. At each level one administrative position was created for the project classified.

TABLE IX

Number of Administrative Additions by SMSA Level / Project

	<u>M</u>	<u>SD</u>	<u>N</u>
A	1.2	.7	23
B	1.0	0.0	5
C	1.1	0.3	17
D	1.2	0.6	92
E	1.1	0.4	<u>210</u>
			347

On the one hand, one might say that the larger SMSA with their multi-teacher projects tended to incur less administrative cost while the smaller projects in the more rural areas incurred higher administrative costs across projects. But, a case can also be made for the fact that the administrative additions in the more rural areas only occur in less than half of the projects. This was true in the more metropolitan areas also. When one compares Table VIII and Table IX it can readily be seen that the ratio of administrative additions to teacher additions was greatest in the metropolitan areas with approximately seven to one, and least in the more rural areas for SMSA E with a ratio of approximately three to one.

Table X, description of consultant services provided to the projects by SMSA level, showed that consultants were used in a small portion of the projects. Here again, the more metropolitan areas with a mean of 2.6 consultant additions for 21 projects reported were the most frequent user of these services. The lower down the list one goes, with the exception of SMSA level D, the less frequent the use of consultant services. In other words, the larger multi-purpose projects carried out by the metropolitan areas tended to have a more favorable teacher-administrative ratio and also to apply consultant services more extensively.

TABLE X

Number of Consultant Additions by SMSA Level / Project

	<u>M</u>	<u>SD</u>	<u>N</u>
A	2.6	2.6	21
B	1.0	0.0	1
C	1.0	0.0	11
D	2.0	2.7	54
E	1.1	0.4	<u>92</u>
			179

One must also call attention to the fact that less than half of the SMSA level A projects employed consultant services, and less than 20% of the projects at SMSA level E employed these services. A total of 179 consultant additions were made as contrasted to a total of 347 administrative positions and 790 teacher additions.

In-Service Training

In total, 174 projects incurred in-service training costs. The highest mean cost for in-service training shown in Table XI occurred at SMSA level A with a mean dollar amount of \$3,526 for the 12 projects that conducted in-service training. The largest number, in terms of frequency of in-service training costs per project, occurred at SMSA level E where 104 projects engaged in in-service training. The smallest cost occurred at SMSA level B where 137 was the mean dollar amount for the 4 projects listing in-service training costs. As a comparative

expenditure, in-service training was not frequently employed by projects during the fiscal year 1966.

TABLE XI

In-Service Training Costs by SMSA Level / Project

	<u>M</u>	<u>SD</u>	<u>N</u>
A	3,526	4,122	12
B	137	21	4
C	403	247	10
D	1,533	5,280	44
E	1,100	3,730	<u>104</u>
			174

Supporting Services

Table XII shows the supporting services expense incurred by projects within SMSA levels. Here the largest mean expenditure occurred at SMSA level A where 14 projects spent a mean of \$6,215 for supporting services. SMSA level E spent the smallest mean dollar amount (\$1,848) but also represented the most frequent use of supporting services with 164 projects reporting expenditures for this category. When looked at as a proportion of the total instructional costs, supporting services represented a small portion of the total instructional costs for the projects. In fact, only 265 projects reported expenses for supporting services.

TABLE XII

Supporting Services Expense by SMSA Level / Project

	<u>M</u>	<u>SD</u>	<u>N</u>
A	6, 215	6, 642	14
B	2, 274	1, 512	5
C	2, 004	1, 304	13
D	3, 072	3, 796	69
E	1, 848	2, 415	<u>164</u>
			265

Other Costs

Table XIII shows the other educational cost incurred by projects within SMSA categories. In this breakout 136 projects reported expenditures as "other educational costs." Again, the largest expenditure in terms of mean dollar amount occurred at SMSA level A. The 15 projects at this level reported a mean of \$6, 603 expended for other educational costs. Here again SMSA level E showed the smallest mean dollar amount (\$1, 404) but also the most frequent use of this category in reporting educational costs with 74 projects.

TABLE XIII

Other Educational Costs by SMSA Level / Project

	<u>M</u>	<u>SD</u>	<u>N</u>
A	6, 603	5, 495	15
B	4, 650	0	1
C	4, 322	3, 474	4
D	3, 423	6, 640	42
E	1, 404	1, 539	<u>74</u>
			136

Health Service Additions

In addition to the salary figures for teacher additions, administrative additions, and consultant services, salaries were also expended for health services, and teacher aids, and other supporting staff. Table XIV shows the number of health service additions by SMSA level. The table also includes the number of projects showing this activity as a category of service for Title I projects.

TABLE XIV

Number of Health Service Additions by SMSA Level / Project

	<u>M</u>	<u>SD</u>	<u>N</u>
A	1.5	0.9	9
B	-	-	-
C	1.0	0.0	11
D	1.1	0.4	58
E	1.0	0.3	<u>107</u>
			185

An examination of this table reveals that 4 of the 5 SMSA levels attempted projects that included health service additions. SMSA level B was not represented by any project attempting these types of ancillary services. The mean number across the four project SMSA levels was close to one and the standard deviation was less than one. There were a total of 185 projects that included health service additions.

Teacher Aids

Turning to the employment of teacher aids as a part of Title I approved projects, Table XV shows teacher aids used extensively. In fact, they were employed in 319 projects. Here SMSA level B employed a mean of 6 teacher aids for the 2 projects at that level. SMSA level E, with 204 projects reporting the use of teacher aids and a mean of slightly over 2 teacher aids per project, had the largest number of projects using this device as part of their project application. Stated another way, SMSA level E had over four hundred teacher aids paid out of Title I funds.

TABLE X V

Number of Teacher Aid Additions by SMSA Level / Project

	<u>M</u>	<u>SD</u>	<u>N</u>
A	3.4	3.9	25
B	6.0	0	2
C	2.8	1.4	16
D	3.3	3.9	72
E	2.2	1.9	<u>204</u>
			319

Other Staff

In terms of other staff member additions, Table XVI shows the use of this category by SMSA level and number of projects. Here 4 of the 5 SMSA levels employed other staff additions to assist in

implementing their projects. SMSA level B did not employ any other staff additions. Significantly, only 36 projects reported the use of other staff additions. One can generalize from Table XVI that this category was not very frequently employed in reporting the personnel expenditures of Title I funds.

TABLE XVI

Number of Other Staff Additions by SMSA Level / Project

	<u>M</u>	<u>SD</u>	<u>N</u>
A	1.5	0.7	7
B	-	-	-
C	1.3	0.4	4
D	2.3	3.1	7
E	1.7	2.1	<u>18</u>
			36

PUPILS

Thus far, we have looked at the grants that were approved by the State Department of Public Instruction, the instructional costs that were involved in the grants, and the breakdown of these instructional costs into salaries, in-service training, supporting services, and other costs incurred. At this point we will turn to a brief description of the pupils who were benefited by Title I funds in the State of Iowa. These data provide, perhaps, a key to relating the financial figures presented.

A detailed analysis of pupil characteristics will be presented later in the report.

This section of the report will deal with the children who received the aid at four levels: in preschool programs, in kindergarten programs, in elementary programs and in secondary programs.

Preschool Children

Table XVII shows the mean number of preschool children by SMSA level included in the projects across the state.

TABLE XVII

Number of Preschool Children by SMSA Level / Project

	<u>M</u>	<u>SD</u>	<u>N</u>
A	-	-	-
B	-	-	-
C	32	3	3
D	51	33	24
E	21	12	<u>27</u>
			54

An examination of Table XVII shows that SMSA levels A and B were not funded for projects that included preschool children. SMSA level E, the most frequent category including preschool children's projects, listed 27 programs. This was closely followed by SMSA level D with 24 programs while SMSA level C had only three programs.

A total of 54 projects involved preschool children.

The very small number of projects including preschool children during the academic year can perhaps best be explained by the fact that the applications were not accepted until December and projects did not get underway until two to three months after first receipt of the project application. For the most part, it was simply a matter of not being able to "tool-up" in time for involvement at this level.

Kindergarten Children

Table XVIII presents graphically the number of kindergarten children involved in SMSA projects across the state. Here we find one SMSA level not represented, that being SMSA level B. The 15 projects for kindergarten children at SMSA level A showed a mean number of pupils involved of 91, i.e., they were typically multiple classroom projects. The smallest mean number of pupils involved in kindergarten projects was 12 and this figure was for the 201 projects from SMSA level E.

TABLE XVIII

Number of Kindergarten Children by SMSA Level / Project

	<u>M</u>	<u>SD</u>	<u>N</u>
A	91	110	15
B	-	-	-
C	35	28	14
D	38	76	59
E	12	14	<u>201</u>
			289

The total of 289 projects were funded which included programs for kindergarten children. The most extensive coverage, in terms of number of pupils, appeared at SMSA level E. Notice the contrast between preschool programs and kindergarten programs. It would appear that where the existing educational structure was such that kindergarten programs could be readily adapted into the existing curriculum, they were in fact employed as the vehicle for improving the status of Title I pupils. Or, one might say, the "tooling-up" process was not prohibitive beyond the preschool level.

Grade 1 - 6 Pupils

At the elementary level, one can see from the figures shown in Table XIX that elementary projects were perhaps the most diversified in terms of sheer number of projects and also in terms of the number of children involved. This, of course, only includes the distributions we have examined thus far: preschool, kindergarten and elementary.

TABLE XIX

Number of Children Grades 1 - 6 by SMSA Level / Project

	<u>M</u>	<u>SD</u>	<u>N</u>
A	302	399	34
B	325	126	3
C	99	84	38
D	184	260	153
E	74	84	<u>462</u>
			690

There is a decided shift both in number of programs and number of children involved as one moves up the educational levels. In this table the largest mean number of pupils involved occurred at SMSA level B. For the three projects reported, a mean of 325 pupils was shown. This was closely followed by the 34 projects reported in SMSA level A where a mean of 302 pupils is shown. Again SMSA level E led all six in terms of both project fundings, with 462, and the total number of pupils involved. This was done while level E also maintained the smallest mean number of pupils per project, i.e., a mean of 74.

Grades 7 - 12 Pupils

Moving to the secondary level, grades 7 - 12, Table XX shows the number of projects involved within each SMSA level. The most salient feature of the table is the fact that this classification included 706 projects. Again emphasizing the finding that as one moves up the educational ladder, there is an increase in the number of projects funded.

TABLE XX

Number of Children Grades 7 - 12 by SMSA Level / Project

	<u>M</u>	<u>SD</u>	<u>N</u>
A	319	475	33
B	251	225	3
C	90	113	34
D	144	373	163
E	57	49	<u>473</u>
			706

Here SMSA level A showed the largest mean number of pupils per project with a mean of 319 for the 33 projects reported. SMSA level B followed with a mean of 251 pupils. But only three projects were involved for this standard metropolitan statistical area. SMSA level E again showed both the greatest number of projects, with 473, and the lowest mean number of pupils per project with 57. The rural nature of this SMSA level is perhaps the best explanation of the two findings going together: (1) that there were the most projects approved in this category, and (2) that the smallest mean number of pupils per project occurred at this level.

Summary

The financial figures presented show that the instructional costs of Title I projects tend to go down as one moves from the densest populations in SMSA level A to the sparsest population in SMSA level E. There is a reduction in mean instructional cost that occurs in direct relation to the SMSA level.

But when the instructional costs are worked out in terms of where the money went, one finds that teacher salaries, while in general higher in the more densely populated SMSA levels, do not afford the full explanation of what in fact did happen to the money. The more densely populated areas also spent proportionally more money on in-service training and supporting service for their programs. When the other costs incurred are examined in relation to the instructional costs, one

also finds that the more densely populated areas represented by SMSA levels A, D and C had the highest other educational costs.

Since salaries represented the largest portion of the instructional costs across the state, a closer examination was given to the distribution of funds in the salary classification.

The use of funds for adding teachers, administrators, consultants, health services, teacher aids and other staff members was presented. Here again the more densely populated areas showed the largest mean increase in number of teacher additions when classified by SMSA level. Strikingly, the number of administrative additions remain constant across SMSA levels with a mean addition of slightly over one at each level.

The use of consultants was greatest at SMSA level A but the spread was not very great and the largest mean reported was 2.6 with three categories showing a mean of one and only two showing a mean of 2 to 2.6.

One might say that the use of consultant additions was fairly uniform across the SMSA levels. In terms of health services, SMSA level A also showed the largest increase with a mean of 1.5. But, four of the five SMSA levels showed a mean of at least one such position for the projects reported.

In terms of teacher aids, there was a fairly uniform usage of teacher aids across four of the five SMSA levels with SMSA level B showing the largest use of Title I funds for teacher aid additions with a mean of 6 for the two projects reported. Other staff member usage

as an expenditure had four of the five SMSA levels using Title I funds for this category and for the five levels the mean number of positions was greater than 1 and less than 3. Overall, the use of Title I money for instructional costs indicated that the more densely populated the area, the greater the tendency for a project to be a multiple project employing several staff additions and supporting service additions, while the administrative costs in terms of personnel remained relatively constant across all SMSA's.

A very brief description of the children involved was presented in this section mainly for the purpose of providing a first look at our efforts to understand the expenditure of funds in terms of the children served. These figures also indicated that as projects moved from pre-school through kindergarten and elementary school, on into the secondary schools, the number of projects funded increased and also the number of children served increased. The elementary and secondary levels showed the largest number of pupils involved both in terms of an actual number and in terms of a proportion.

During this first year of operation, one could surmise that the existing educational structure was the most frequently used vehicle for implementing the aims of Title I funds.

The most salient finding of this section of the report might be stated as the pointing out of the fact that an existing educational structure was employed with a significant degree of efficiency and success in helping our children who have special problems in terms of their educational attainment.

PART II

ADMINISTRATIVE COMMUNICATIONS

In this part of the report, we have examined in detail the objectives, reports and analyses generated and public releases from the Title I programs. The major emphasis in this section is on the objectives stated for the 514 school districts involved in Title I.

The stated objectives of the 514 school districts were classified into five major areas of achievement, ability, attitudes, behavior, and other areas. There were a total of 28 possible objective classifications. Under achievement, there were 6 possibilities. Under ability, there were 4 possibilities for further clarification. Attitudes allowed for a subclassification into five major areas. Behavior allowed for five distinctions in objective classification. Other areas, the final listing, provided for eight subclassifications of objectives.

The stated objectives were examined in terms of frequency of use of the objectives by school districts, the use of the objectives according to Standard Metropolitan Statistical Areas (SMSA) and in relation to the funds that were expended for the Title I projects.

Table I of Section II shows the specific objectives by major category for the projects. In terms of frequency, the table showed that improved reading performance was by far the most frequently listed objective. Four-hundred-eighty-nine of the 514, or 95.14% of the 514 school districts, listed this as an objective.

The second most frequently stated objective was that of staff and administrative innovations. This was listed by 76.46% of the school districts. Improving classroom performance in other than reading was the third most frequently listed objective, and accounted for 66.54% of the classifications.

TABLE I

Title I Projects in Iowa 1965-66
Frequency of Stated Objectives for 514 School Districts

	<u>N</u>	<u>Percent</u>
<u>Achievement</u>		
1. Improve Standardized Test Performance	24	4.67
2. Improve Reading Performance	489	95.14
3. Improve Classroom Performance in other than Reading	342	66.54
4. Other Achievement Objective	138	26.85
5. Additional Course Offerings	124	24.12
6. Special Class - Tutoring - Reduce Class Size	421	81.91
<u>Ability</u>		
1. Improve Standardized Test Performance	11	2.14
2. Improve Verbal Functioning Level	122	23.74
3. Improve Non-Verbal Functioning Level	80	15.56
4. Other Ability Objectives	6	1.17
<u>Attitudes</u>		
1. Improve Child's Self-Image	102	19.84
2. Improve Attitude Toward School and Education	166	32.30
3. Raise Occupation and/or Education Aspirations	85	16.54
4. Increase Expectation of School Success	25	4.86
5. Other Attitude Objectives	34	6.61

TABLE I (continued)

Behavior

1. Improve Average Daily Attendance	51	9.92
2. Decrease Dropout Rate	103	20.04
3. Reduce Discipline	16	3.11
4. Improve Attention Span	29	5.64
5. Other Behavior Objectives	24	4.67

Other Areas

1. Improve Physical Health	237	46.11
2. Improve Nutrition	127	24.71
3. Improve Emotional/Social Stability of Child or Family	172	33.46
4. Provide Clothing	21	4.09
5. Staff and Administration Innovations (Hiring Aides, In-service Training)	393	76.46
6. Pupil Personnel Services (Guidance Counseling, Social Work, Speech, Psychologist)	209	40.66
7. Library or Materials Center	118	22.96
8. Minor Construction or Remodeling	195	37.94

Because school districts could list more than one objective and, in fact, did list more than one objective for their projects, there is an overlap in the number of objectives stated. Because of the small number of districts utilizing certain of the objective categories, they were collapsed into thirteen more descriptive and summarizing categories.

Classification by Project Objective

The previous table presented the incidence of projects as classified according to their stated objectives. It is also important to know the frequency of pupils in each objective category since the number of pupils involved in a given project varies widely from project to project. A summary of pupils classified by the objective of the project within which they are identified or involved will reflect:

- (a) The number and proportion of pupils receiving specific types of instruction or benefits as reflected by the objectives.
- (b) Changes in objective emphasis across grade level or sex classification in grouping pupils by various objectives.

In compiling these summaries, it was decided to collapse some of the previous objective categories into fewer categories because of either the overlap in meaning or the very small number of times the objective was listed. Therefore, the summaries by grade, sex and involved versus non-involved status utilize the following objectives:

1. Improve Standardized Test Performance
2. Improve Reading Performance
3. Other Achievement Objectives and Additional Course Offerings
4. Special Class - Tutoring - Reduce Class Size
5. All Ability Objectives (Standardized Test Performance, Verbal and Non-Verbal Functioning)
6. All Attitude Objectives
7. All Behavior Objectives
8. Improve Physical Health
9. Improve Emotional/Social Stability of Child or Family
10. Staff and Administration Innovations (Hiring Aides, In-service Training)
11. Pupil Personnel Services (Guidance Counseling, Social Work, Speech, Psychologist)

12. Library or Materials Center
13. Minor Construction or Remodeling

Tables II to IV inclusive present the number and percent of pupils in grades 3 through 5 as classified by the objectives of the projects in which they are placed. Approximately 76% of the pupils in grades 3 through 5 as submitted on lists to the State Department of Public Instruction were involved in projects as opposed to simply being identified for a project. More boys are represented in projects than girls at each grade level. Objectives 2, 3, 4 and 10 seem to affect pupils the greatest, which is consistent with the previously found emphasis on reading, special classes and staff or administrative innovations.

Table V provides a summary table of Grades 3, 4 and 5 combined. One can quickly verify that boys are more frequently represented in each objective category. In addition, the table summarizes the proportion of pupils at the grade levels 3, 4 and 5 potentially affected by each objective. Table VI presents in one easily read table the number of pupils in each category of the previous summaries.

Similar tables have been prepared for secondary pupils in grades 7 through 12 and are presented following the summary for grades 3 through 5 inclusive. Again, objectives 2, 3, 4 and 10 accounted for the largest number of pupils. Of the 27,305 secondary pupils involved in Title I projects, 15,536 can be accounted for by these four objectives. Clearly, the emphasis of the first year of operation centered upon the improvement of reading, achievement, special classes and expanded

PUPILS CLASSIFIED BY TYPE OF PROJECT OBJECTIVE
GRADE 3

Objective		Boys		Girls		Total	
		Inv.	Non.	Inv.	Non.	Inv.	Non.
1	N	34	5	8	4	42	9
	%	0.6	0.1	0.1	0.1	0.7	0.2
2	N	469	105	255	89	724	194
	%	8.3	1.9	4.5	1.6	12.8	3.4
3	N	352	89	187	74	539	163
	%	6.2	1.6	3.3	1.3	9.5	2.9
4	N	422	102	233	97	655	199
	%	7.4	1.8	4.1	1.7	11.5	3.5
5	N	77	30	45	25	122	55
	%	1.4	0.5	0.8	0.4	2.2	1.0
6	N	154	47	74	35	228	82
	%	2.7	0.8	1.3	0.6	4.0	1.4
7	N	92	21	35	18	127	39
	%	1.6	0.4	0.6	0.3	2.2	0.7
8	N	229	49	116	47	345	96
	%	4.0	0.9	2.0	0.8	6.1	1.7
9	N	126	39	68	41	194	80
	%	2.2	0.7	1.2	0.7	3.4	1.4
10	N	447	121	275	98	722	219
	%	7.9	2.1	4.8	1.7	12.7	3.9
11	N	177	38	109	33	286	71
	%	3.1	0.7	1.9	0.6	5.0	1.3
12	N	76	20	58	16	134	36
	%	1.3	0.4	1.0	0.3	2.4	0.6
13	N	155	38	87	30	242	68
	%	2.7	0.7	1.5	0.5	4.3	1.2
Total	N	2810	704	1550	607	4360	1311
	%	50.0	12.4	27.3	10.7	76.9	23.1
Grand Total						5671	

TABLE III

39

PUPILS CLASSIFIED BY TYPE OF PROJECT OBJECTIVE
GRADE 4

Objective		Boys		Girls		Total	
		Inv.	Non.	Inv.	Non.	Inv.	Non.
1	N	28	3	21	0	49	3
	%	0.4	0.0	0.3	0.0	0.7	0.0
2	N	552	130	359	107	911	237
	%	8.1	1.9	5.3	1.6	13.3	3.5
3	N	346	129	262	89	608	218
	%	5.1	1.9	3.8	1.3	8.9	3.2
4	N	513	148	339	119	852	267
	%	7.5	2.2	5.0	1.7	12.5	3.9
5	N	63	29	50	20	113	49
	%	0.9	0.4	0.7	0.3	1.7	0.7
6	N	192	65	146	39	338	104
	%	2.8	1.0	2.1	0.6	4.9	1.5
7	N	83	47	77	20	160	67
	%	1.2	0.7	1.1	0.3	2.3	1.0
8	N	227	43	155	41	382	84
	%	3.3	0.6	2.3	0.6	5.6	1.2
9	N	143	42	103	40	246	82
	%	2.1	0.6	1.5	0.6	3.6	1.2
10	N	509	153	325	120	834	273
	%	7.4	2.2	4.8	1.8	12.2	4.0
11	N	194	56	103	41	297	97
	%	2.8	0.8	1.5	0.6	4.3	1.4
12	N	92	17	68	18	160	35
	%	1.3	0.2	1.0	0.3	2.3	0.5
13	N	173	33	129	34	302	67
	%	2.5	0.5	1.9	0.5	4.4	1.0
Total	N	3115	895	2137	688	5252	1583
	%	45.6	13.1	31.3	10.1	76.8	23.2
Grand Total							6835

TABLE IV

40

PUPILS CLASSIFIED BY TYPE OF PROJECT OBJECTIVE
GRADE 5

Objective		Boys		Girls		Total	
		Inv.	Non.	Inv.	Non.	Inv.	Non.
1	N	40	5	19	2	59	7
	%	0.6	0.1	0.3	0.0	0.8	0.1
2	N	542	145	390	110	932	255
	%	7.5	2.0	5.4	1.5	12.9	3.5
3	N	381	131	286	91	667	222
	%	5.3	1.8	4.0	1.3	9.2	3.1
4	N	476	166	388	118	864	284
	%	6.6	2.3	5.4	1.6	12.0	3.9
5	N	80	32	59	23	139	55
	%	1.1	0.4	0.8	0.3	1.9	0.8
6	N	159	70	136	41	295	111
	%	2.2	1.0	1.9	0.6	4.1	1.5
7	N	91	31	71	14	162	45
	%	1.3	0.4	1.0	0.2	2.2	0.6
8	N	269	72	161	51	430	123
	%	3.7	1.0	2.2	0.7	6.0	1.7
9	N	144	63	120	43	264	106
	%	2.0	0.9	1.7	0.6	3.7	1.5
10	N	499	176	366	138	865	314
	%	6.9	2.4	5.1	1.9	12.0	4.4
11	N	199	77	141	39	340	116
	%	2.8	1.1	2.0	0.5	4.7	1.6
12	N	98	8	62	21	160	29
	%	1.4	0.1	0.9	0.3	2.2	0.4
13	N	172	49	113	39	285	88
	%	2.4	0.7	1.6	0.5	3.9	1.2
Total	N	3150	1025	2312	730	5462	1755
	%	43.6	14.2	32.0	10.1	75.7	24.3
Grand Total							7217

TABLE V

41

PUPILS CLASSIFIED BY TYPE OF PROJECT OBJECTIVE
TOTAL GRADES 3, 4, AND 5

Objective		Boys		Girls		Total	
		Inv.	Non.	Inv.	Non.	Inv.	Non.
1	N	102	13	48	6	150	19
	%	0.5	0.1	0.2	0.0	0.8	0.1
2	N	1563	380	1004	306	2567	686
	%	7.9	1.9	5.1	1.6	13.0	3.5
3	N	1079	349	735	254	1814	603
	%	5.5	1.8	3.7	1.3	9.2	3.1
4	N	1411	416	960	334	2371	750
	%	7.2	2.1	4.9	1.7	12.0	3.8
5	N	220	91	154	68	374	159
	%	1.1	0.5	0.8	0.3	1.9	0.8
6	N	505	182	356	115	861	297
	%	2.6	0.9	1.8	0.6	4.4	1.5
7	N	266	99	183	52	449	151
	%	1.3	0.5	0.9	0.3	2.3	0.8
8	N	725	164	432	139	1157	303
	%	3.7	0.8	2.2	0.7	5.9	1.5
9	N	413	144	291	124	704	268
	%	2.1	0.7	1.5	0.6	3.6	1.4
10	N	1455	450	966	356	2421	806
	%	7.4	2.3	4.9	1.8	12.3	4.1
11	N	570	171	353	113	923	284
	%	2.9	0.9	1.8	0.6	4.7	1.4
12	N	266	45	188	55	454	100
	%	1.3	0.2	1.0	0.3	2.3	0.5
13	N	500	120	329	103	829	223
	%	2.5	0.6	1.7	0.5	4.2	1.1
Total	N	9075	2624	5999	2025	15074	4649
	%	46.0	13.3	30.4	10.3	76.4	23.6
						Grand Total	19723

TABLE VI
PUPILS CLASSIFIED BY TYPE OF PROJECT OBJECTIVE

	Grade 3				Grade 4				Grade 5			
	Boys		Girls		Boys		Girls		Boys		Girls	
	Inv.	Non.	Inv.	Non.	Inv.	Non.	Inv.	Non.	Inv.	Non.	Inv.	Non.
1	34	5	8	4	28	3	21	0	40	5	19	2
2	469	105	255	89	552	130	359	107	542	145	390	110
3	352	89	187	74	346	129	262	89	381	131	286	91
4	422	102	233	97	513	148	339	119	476	166	388	118
5	77	30	45	25	63	29	50	20	80	32	59	23
6	154	47	74	35	192	65	146	39	159	70	136	41
7	92	21	35	18	83	47	77	20	91	31	71	14
8	229	49	116	47	227	43	155	41	269	72	161	51
9	126	39	68	41	143	42	103	40	144	63	120	43
10	447	121	275	98	509	153	325	120	499	176	366	138
11	177	38	109	33	194	56	103	41	199	77	141	39
12	76	20	58	16	92	17	68	18	98	8	62	21
13	155	38	87	30	173	33	129	34	172	49	113	39
Totals	2810	704	1550	607	3115	895	2137	1583	3150	1025	2312	730

offerings plus the addition of staff and/or administrative innovation.

At the secondary level, boys represented 41 percent of the total pupils classified by objective. This listing included both involved and non-involved pupils. In contrast, boys represented 46 percent of the total at the elementary level. The complete grade level and summary analyses for the secondary level are included as Tables VII through XIV.

From the grades included in this analysis, one could also conclude that the probability of being included in a program, once the need has been established, is greater at the elementary level. The actual percents show that 76.4% of those pupils identified at the elementary level were included in programs while only 70.6% of those identified were included in programs at the secondary level.

OBJECTIVES

1. Improve Standardized Test Performance
2. Improve Reading Performance
3. Other Achievement Objectives and Additional Course Offerings
4. Special Class-Tutoring--Reduce Class Size
5. All Ability Objectives (Standardized Test Performance, Verbal and Non-Verbal Functioning)
6. All Attitude Objectives
7. All Behavior Objectives
8. Improve Physical Health
9. Improve Emotional/Social Stability of Child or Family
10. Staff and Administration Innovations (Hiring Aides, Inservice Training)
11. Pupil Personnel Services (Guidance Counseling, Social Work, Speech, Psychologist)
12. Library or Materials Center
13. Minor Construction or Remodeling

TABLE VII

PUPILS CLASSIFIED BY TYPE OF PROJECT OBJECTIVE
GRADE 7

Objective		Boys		Girls		Total	
		Inv.	Non.	Inv.	Non.	Inv.	Non.
1	N	32	5	16	6	48	11
	%	0.6	0.1	0.3	0.1	0.8	0.2
2	N	390	120	254	95	644	215
	%	6.9	2.1	4.5	1.7	11.4	3.8
3	N	268	114	180	94	448	208
	%	4.7	2.0	3.2	1.7	7.9	3.7
4	N	368	131	233	107	601	238
	%	6.5	2.3	4.1	1.9	10.6	4.2
5	N	77	21	42	11	119	32
	%	1.4	0.4	0.7	0.2	2.1	0.6
6	N	200	81	134	75	334	156
	%	3.5	1.4	2.4	1.3	5.9	2.8
7	N	129	59	79	54	208	113
	%	2.3	1.0	1.4	1.0	3.7	2.0
8	N	183	51	110	43	293	94
	%	3.2	0.9	1.9	0.8	5.2	1.7
9	N	114	54	82	55	196	109
	%	2.0	1.0	1.4	1.0	3.5	1.9
10	N	360	117	232	104	592	221
	%	6.4	2.1	4.1	1.8	10.5	3.9
11	N	153	71	88	57	241	128
	%	2.7	1.3	1.6	1.0	4.3	2.3
12	N	58	10	30	7	88	17
	%	1.0	0.2	0.5	0.1	1.6	0.3
13	N	137	49	79	37	216	86
	%	2.4	0.9	1.4	0.7	3.8	1.5
Total	N	2469	883	1559	745	4028	1628
	%	43.7	15.6	27.6	13.2	71.2	28.8

Grand Total 5656

TABLE VIII

46

PUPILS CLASSIFIED BY TYPE OF PROJECT OBJECTIVE
GRADE 8

Objective		Boys		Girls		Total	
		Inv.	Non.	Inv.	Non.	Inv.	Non.
1	N	28	8	23	9	51	17
	%	0.5	0.1	0.4	0.1	0.8	0.3
2	N	400	122	292	120	692	242
	%	6.5	2.0	4.8	2.0	11.3	3.9
3	N	279	104	200	96	479	200
	%	4.6	1.7	3.3	1.6	7.8	3.3
4	N	358	135	264	123	622	258
	%	5.8	2.2	4.3	2.0	10.1	4.2
5	N	64	22	49	15	113	37
	%	1.0	0.4	0.8	0.2	1.8	0.6
6	N	208	77	168	79	376	156
	%	3.4	1.3	2.7	1.3	6.1	2.5
7	N	137	59	103	59	240	118
	%	2.2	1.0	1.7	1.0	3.9	1.9
8	N	187	54	141	47	328	101
	%	3.1	0.9	2.3	0.8	5.3	1.6
9	N	126	52	98	61	224	113
	%	2.1	0.8	1.6	1.0	3.7	1.8
10	N	357	122	280	112	637	234
	%	5.8	2.0	4.6	1.8	10.4	3.8
11	N	146	70	116	71	262	141
	%	2.4	1.1	1.9	1.2	4.3	2.3
12	N	78	16	43	10	121	26
	%	1.3	0.3	0.7	0.2	2.0	0.4
13	N	136	53	102	52	238	105
	%	2.2	0.9	1.7	0.8	3.9	1.7
Total	N	2504	894	1879	854	4383	1748
	%	40.8	14.6	30.6	13.9	71.5	28.5
Grand Total							6131

TABLE IX

PUPILS CLASSIFIED BY TYPE OF PROJECT OBJECTIVE
GRADE 9

Objective		Boys		Girls		Total	
		Inv.	Non.	Inv.	Non.	Inv.	Non.
1	N	38	7	20	5	58	12
	%	0.5	0.1	0.2	0.1	0.7	0.2
2	N	533	183	407	135	940	318
	%	6.5	2.2	4.9	1.6	11.4	3.9
3	N	430	166	313	125	743	291
	%	5.2	2.0	3.8	1.5	9.0	3.5
4	N	492	159	347	121	839	280
	%	6.0	1.9	4.2	1.5	10.2	3.4
5	N	85	21	73	16	158	37
	%	1.0	0.3	0.9	0.2	1.9	0.4
6	N	285	112	196	92	481	204
	%	3.5	1.4	2.4	1.1	5.8	2.5
7	N	185	77	133	65	318	142
	%	2.2	0.9	1.6	0.8	3.9	1.7
8	N	255	82	204	63	459	145
	%	3.1	1.0	2.5	0.8	5.6	1.8
9	N	152	68	116	62	268	130
	%	1.8	0.8	1.4	0.8	3.2	1.6
10	N	532	175	410	131	942	306
	%	6.4	2.1	5.0	1.6	11.4	3.7
11	N	172	90	154	84	326	174
	%	2.1	1.1	1.9	1.0	4.0	2.1
12	N	102	19	74	15	176	34
	%	1.2	0.2	0.9	0.2	2.1	0.4
13	N	197	67	154	51	351	118
	%	2.4	0.8	1.9	0.6	4.3	1.4
Total	N	3458	1226	2601	965	6059	2191
	%	41.9	14.9	31.5	11.7	73.4	26.6

Grand Total

8250

TABLE X

48

PUPILS CLASSIFIED BY TYPE OF PROJECT OBJECTIVE
GRADE 10

Objective		Boys		Girls		Total	
		Inv.	Non.	Inv.	Non.	Inv.	Non.
1	N	33	8	15	5	48	13
	%	0.4	0.1	0.2	0.1	0.6	0.2
2	N	484	189	330	153	814	342
	%	6.4	2.5	4.3	2.0	10.7	4.5
3	N	368	203	258	170	626	373
	%	4.8	2.7	3.4	2.2	8.2	4.9
4	N	424	205	268	152	692	357
	%	5.6	2.7	3.5	2.0	9.1	4.9
5	N	89	25	61	20	150	45
	%	1.2	0.3	0.8	0.3	2.0	0.6
6	N	261	117	172	102	433	219
	%	3.4	1.5	2.3	1.3	5.7	2.9
7	N	173	73	92	62	265	135
	%	2.3	1.0	1.2	0.8	3.5	1.8
8	N	245	61	158	52	403	113
	%	3.2	0.8	2.1	0.7	5.3	1.5
9	N	130	80	87	52	217	132
	%	1.7	1.1	1.1	0.7	2.8	1.7
10	N	454	185	320	169	774	354
	%	6.0	2.4	4.2	2.2	10.2	4.6
11	N	189	121	105	78	294	199
	%	2.5	1.6	1.4	1.0	3.9	2.6
12	N	100	20	65	14	165	34
	%	1.3	0.3	0.9	0.2	2.2	0.4
13	N	171	79	111	57	282	136
	%	2.2	1.0	1.5	0.7	3.7	1.8
Total	N	3044	1366	2042	1086	5163	2452
	%	40.4	17.9	26.8	14.3	67.8	32.2
Grand Total							7615

TABLE XI

PUPILS CLASSIFIED BY TYPE OF PROJECT OBJECTIVE
GRADE 11

Objective		Boys		Girls		Total	
		Inv.	Non.	Inv.	Non.	Inv.	Non.
1	N	27	8	22	4	49	12
	%	0.4	0.1	0.4	0.1	0.8	0.2
2	N	392	133	310	112	702	245
	%	6.4	2.2	5.1	1.8	11.5	4.0
3	N	300	131	224	118	524	249
	%	4.9	2.1	3.7	1.9	8.6	4.1
4	N	353	129	249	118	602	247
	%	5.8	2.1	4.1	1.9	9.8	4.0
5	N	64	29	50	28	114	57
	%	1.0	0.5	0.8	0.5	1.9	0.9
6	N	196	93	127	69	323	162
	%	3.2	1.5	2.1	1.1	5.3	2.6
7	N	113	52	76	55	189	107
	%	1.8	0.8	1.2	0.9	3.1	1.7
8	N	185	59	173	59	358	118
	%	3.0	1.0	2.8	1.0	5.9	1.9
9	N	105	32	88	31	193	63
	%	1.7	0.5	1.4	0.5	3.2	1.0
10	N	389	129	320	111	709	240
	%	6.4	2.1	5.2	1.8	11.6	3.9
11	N	146	54	102	41	248	95
	%	2.4	0.9	1.7	0.7	4.1	1.6
12	N	87	28	60	18	147	46
	%	1.4	0.5	1.0	0.3	2.4	0.8
13	N	126	56	98	39	224	95
	%	2.1	0.9	1.6	0.6	3.7	1.6
Total	N	2483	933	1899	803	4382	1706
	%	40.6	15.3	31.0	13.1	71.6	28.4
Grand Total							6118

TABLE XII

50

PUPILS CLASSIFIED BY TYPE OF PROJECT OBJECTIVE
GRADE 12

Objective		Boys		Girls		Total	
		Inv.	Non.	Inv.	Non.	Inv.	Non.
1	N	18	8	12	7	30	15
	%	0.4	0.2	0.2	0.1	0.6	0.3
2	N	293	120	224	101	517	221
	%	6.0	2.5	4.6	2.1	10.6	4.5
3	N	243	132	188	97	431	229
	%	5.0	2.7	3.8	2.0	8.8	4.7
4	N	261	124	194	107	455	231
	%	5.3	2.5	4.0	2.2	9.3	4.7
5	N	52	23	43	19	95	42
	%	1.1	0.5	0.9	0.4	1.9	0.9
6	N	149	87	117	55	266	142
	%	3.0	1.8	2.4	1.1	5.4	2.9
7	N	89	46	62	37	151	83
	%	1.8	0.9	1.3	0.8	3.1	1.7
8	N	159	59	141	47	300	106
	%	3.3	1.2	2.9	1.0	6.1	2.2
9	N	71	33	48	20	119	53
	%	1.5	0.7	1.0	0.4	2.4	1.1
10	N	274	143	237	100	511	243
	%	5.6	2.9	4.9	2.0	10.5	5.0
11	N	95	53	85	34	180	87
	%	1.9	1.1	1.7	0.7	3.7	1.8
12	N	43	29	39	24	82	53
	%	0.9	0.6	0.8	0.5	1.7	1.1
13	N	99	54	54	37	153	91
	%	2.0	1.1	1.1	0.8	3.1	1.9
Total	N	1846	911	1444	685	3290	1596
	%	37.8	18.6	29.6	14.0	67.3	32.7

Grand Total

4886

TABLE XIII

51

PUPILS CLASSIFIED BY TYPE OF PROJECT OBJECTIVE
TOTAL GRADES 7-12

Objective		Boys		Girls		Total	
		Inv.	Non.	Inv.	Non.	Inv.	Non.
1	N	176	44	108	36	284	80
	%	0.5	0.1	0.3	0.1	0.7	0.2
2	N	2492	867	1817	716	4309	1583
	%	6.4	2.2	4.7	1.9	11.1	4.1
3	N	1888	850	1363	700	3251	1550
	%	4.9	2.2	3.5	1.8	8.4	4.0
4	N	2256	883	1555	728	3811	1611
	%	5.8	2.3	4.0	1.9	9.9	4.2
5	N	431	141	318	109	749	250
	%	1.1	0.4	0.8	0.3	1.9	0.6
6	N	1299	567	914	472	2213	1039
	%	3.4	1.5	2.4	1.2	5.7	2.7
7	N	826	366	545	332	1371	698
	%	2.1	0.9	1.4	0.9	3.5	1.8
8	N	1214	366	927	311	2141	677
	%	3.1	0.9	2.4	0.8	5.5	1.8
9	N	698	319	519	281	1217	600
	%	1.8	0.8	1.3	0.7	3.1	1.6
10	N	2366	871	1799	727	4165	1598
	%	6.1	2.3	4.7	1.9	10.8	4.1
11	N	901	459	650	365	1551	824
	%	2.3	1.2	1.7	0.9	4.0	2.1
12	N	468	122	311	88	779	210
	%	1.2	0.3	0.8	0.2	2.0	0.5
13	N	866	358	598	273	1464	631
	%	2.2	0.9	1.5	0.7	3.8	1.6
Total	N	15881	6213	11424	5138	27305	11351
	%	41.1	16.1	29.6	13.3	70.6	29.4
Grand Total						38656	

TABLE XIV

PUPILS CLASSIFIED BY TYPE OF PROJECT OBJECTIVE

	Grade 7				Grade 8				Grade 9			
	Boys		Girls		Boys		Girls		Boys		Girls	
	Inv.	Non.	Inv.	Non.	Inv.	Non.	Inv.	Non.	Inv.	Non.	Inv.	Non.
1	32	5	16	6	28	8	23	9	38	7	20	5
2	390	120	254	95	400	122	292	120	533	183	407	135
3	268	114	180	94	279	104	200	96	430	166	313	125
4	368	131	233	107	358	135	264	123	492	159	347	121
5	77	21	42	11	64	22	49	15	85	21	73	16
6	200	81	134	75	208	77	168	79	285	112	196	92
7	129	59	79	54	137	59	103	59	185	77	133	65
8	183	51	110	43	187	54	141	47	255	82	204	63
9	114	54	82	55	126	52	98	61	152	68	116	62
10	360	117	232	104	357	122	280	112	532	175	410	131
11	153	71	88	57	146	70	116	71	172	90	154	84
12	58	10	30	7	78	16	43	10	102	19	74	15
13	137	49	79	37	136	53	102	52	197	67	154	51
Totals	2469	833	1559	745	2504	894	1879	854	3458	1226	2601	965

TABLE XIV (Continued)

PUPILS CLASSIFIED BY TYPE OF PROJECT OBJECTIVE

	Grade 10				Grade 11				Grade 12			
	Boys		Girls		Boys		Girls		Boys		Girls	
	Inv.	Non.	Inv.	Non.	Inv.	Non.	Inv.	Non.	Inv.	Non.	Inv.	Non.
1	33	8	15	5	27	8	22	4	18	8	12	7
2	484	189	330	153	392	133	310	112	293	120	224	101
3	368	203	258	170	300	131	224	118	243	132	188	97
4	424	205	268	152	353	129	249	118	261	124	194	107
5	85	25	61	20	64	29	50	28	52	23	43	19
6	261	117	172	102	196	93	127	69	149	87	117	55
7	173	73	92	62	113	52	76	55	89	46	62	37
8	245	61	158	52	185	59	173	59	159	59	141	47
9	130	80	87	52	105	32	88	31	71	33	48	20
10	454	185	320	169	389	129	320	111	274	143	237	100
11	189	121	105	78	146	54	102	41	95	53	85	34
12	100	20	65	14	87	28	60	18	43	29	39	24
13	171	79	111	57	126	56	98	39	99	54	54	37
Totals	3121	1366	2042	1086	2483	933	1899	803	1846	911	1444	685

ADMINISTRATIVE PROJECT INFORMATION BY OBJECTIVE TITLE

While the preceding tables showed the objective classifications for the grade levels that achievement information existed, they were in no sense complete in terms of presenting a relationship to the administrative information that was presented in the preceding section.

Here we are attempting to classify information by objective type using the same categories as those already presented for financial information. This is done to better relate information related to objectives and information related to funding.

You will notice that the sequencing of Tables XV through XX on the following pages is exactly the same as that presented in Section I.

Here, the objectives already reduced on the preceding pages were further reduced into 9 objective types:

1. Practical Arts
2. Health Services
3. Class Reduction
4. Special Education
5. Guidance, Counseling, and Social Work
6. Preschool-Kindergarten Enrichment
7. Dropout
8. Curriculum Extension
9. Remediation

These nine categories represent the basic areas of objective by application. It was felt that they succinctly state each application

concentration. The reader should remember that in some instances classification of a project into one of the nine objective categories represented a judgment, albeit our best judgment, of the placement of the locally stated project objectives.

Preschool Children by Objective Type

Table XV shows the relationship between preschool children involved and their classification by objective type. Moving across from left to right the table shows the mean number of children, standard deviation, the number of projects classified in which children were involved, and lastly, the maximum number of children in each objective category.

Objective 6 (Preschool-Kindergarten Enrichment) was, as one would expect, the most frequently listed objective for projects involving preschool children. Thirty-nine projects listed this objective. Also, ten of the projects listed remediation in a more general sense as an objective at this project level. There were no project objectives under the categories of practical arts, class reduction, or dropout studies. The concentration of projects at the preschool level, when classified by objective type, were in categories 6, 9, and 2.

TABLE XV
NUMBER OF PRESCHOOL CHILDREN PER PROJECT
BY OBJECTIVE TYPE

	<u>M</u>	<u>SD</u>	<u>N</u>	<u>Max</u>
1	0.0	0.0	0	0.0
2	27.0	15.9	6	60.0
3	0.0	0.0	0	0.0
4	2.0	0.0	1	2.0
5	26.0	24.0	2	50.0
6	36.5	30.3	39	150.0
7	0.0	0.0	0	0.0
8	8.0	0.0	1	8.0
9	35.3	20.1	<u>10</u>	60.0
			59	

When this information is related back to Table II, the fact that SMSA Levels C, D and E represented all of the approved funds for preschool projects, the numbers of children involved and the numbers within each project objective can be better understood. Simply stated, these more rural areas of the state had preschool projects funded and their efforts concentrated on enrichment, remediation and health services for these youngsters.

Kindergarten Children by Objective Type

Table XVI shows the distribution of kindergarten pupils when

classified by the 9 objective types. The vast majority of the projects listed remediation as the prime objective at the kindergarten level. This figure (198) represented far and away the most frequent of the 302 objectives listed. Health services was the next most frequently listed objective type, but only represented 31 project listings. Third in importance was curriculum expansion at the kindergarten level. But, these objectives were insignificant in relation to the frequency of the remediation tabulation.

TABLE XVI

NUMBER OF KINDERGARTEN PUPILS PER PROJECT
BY OBJECTIVE TYPE

	<u>M</u>	<u>SD</u>	<u>N</u>	<u>Max</u>
1	9.0	0	1	9.0
2	26.5	55.9	31	298.0
3	27.3	36.8	16	154.0
4	19.1	32.1	13	124.0
5	25.7	22.6	7	80.0
6	37.8	38.1	15	141.0
7	0.0	0.0	0	0.0
8	34.4	57.4	21	226.0
9	20.5	49.1	<u>198</u>	575.0
			302	

Table XVI is related to Table III of Part I. Viewing the relationship between approval of elementary funds, which shows the concentration of projects in SMSA Level B and E, the figures for numbers of kindergarten children by objective type become much more meaningful. Again, the significant increase from preschool to kindergarten projects (59 to 302) demonstrated the extensive use of existing educational facilities during the first year of Title I involvement.

Children in Grades 1 - 6 by Objective Type

Table XVII, the classification of pupils grade 1 through 6 by objective type, again included the distributions in terms of pupils and the number of projects listing the nine categories of objectives. Here, the ninth objective - that of remediation - was by far the most frequently listed objective. A total of 556 of the projects in grades 1 through 6 made this particular objective choice. Curriculum expansion was closely followed by class reduction as the second and third objectives for elementary projects. The largest mean number of pupils classified fell under objective 2 (health services) which was closely followed by objectives 3 and 5.

TABLE XVII

NUMBER OF PUPILS IN GRADES 1 - 6 PER PROJECT
BY OBJECTIVE TYPE

	<u>M</u>	<u>SD</u>	<u>N</u>	<u>Max</u>
1	53.3	22.6	4	82.0
2	153.3	228.4	37	1256.0
3	125.3	222.6	42	978.0
4	77.2	160.8	21	741.0
5	132.9	114.1	10	463.0
6	53.8	35.0	4	103.0
7	0.0	0.0	0	0.0
8	118.8	160.4	44	1036.0
9	108.7	172.7	556	2589.0

The elementary grades, representing the majority of the funding at the district level, significantly listed practical arts objectives and those unrelated to elementary school, i.e., dropout and preschool-kindergarten enrichment, least often.

Pupils in Grades 7 - 12 by Project Objective

At the secondary level, the emphasis in terms of objective type was again on remediation. The total of 510 projects identified an objective at this level. Significantly, objective category 8 (curriculum expansion) showed the second highest number of projects with 72 reporting this objective. There was a decided shift in emphasis towards

practical arts objectives. While the elementary level showed 4 projects with this objective, at the secondary level there were 41 such listings.

Table XVIII also shows that health services, while not included among the three most frequently listed objectives, did have the highest mean number of pupils benefiting. When the table is examined in terms of the mean number of pupils involved, health services showed a mean of 172.7 and represented the objective with the broadest contact at the secondary level. The next closest objective was that of class reduction (objective 3) which had approximately 71 pupils less than objective two as a mean. One might generalize from these data that remediation was by far the most frequently named objective but the relationship of the number of times stated and the number of pupils involved brought the health services objective to the fore.

TABLE XVIII
NUMBER OF PUPILS IN GRADES 7 - 12 PER PROJECT
BY OBJECTIVE TYPE

	<u>M</u>	<u>SD</u>	<u>N</u>	<u>Max</u>
1	48.1	35.1	41	146.0
2	172.7	330.9	36	1934.0
3	101.1	168.7	27	922.0
4	80.1	120.3	15	367.0
5	100.0	92.5	21	416.0
6	25.0	13.6	3	44.0

TABLE XVIII (continued)

	<u>M</u>	<u>SD</u>	<u>N</u>	<u>Max</u>
7	90.0	122.4	7	387.0
8	97.2	213.3	72	1812.0
9	88.9	226.0	510	4230.0

Instructional Cost by Objective Type

When instructional costs were examined as they related to the stated objectives of Title I projects, a different perspective was gained than the one shown by Table VI of Part I. The earlier SMSA classification easily led to the generalization that as one moved from the more urban, densely populated areas into the more rural areas, the cost factor for instruction went proportionally down. As a function of objective type, instructional cost showed quite different relationships.

It is well to remember that this new classification of cost, while presenting a different facet of cost disbursement, did negate much of the information gained when costs were examined by SMSA level. Each comparison presents another facet of the picture but only at the cost of some of the previous information. Table XIX shows the mean, standard deviation, number of projects, and the maximum dollar amount granted within each of the nine objective types.

TABLE XIX
INSTRUCTIONAL COSTS PER PROJECT
BY OBJECTIVE TYPE

	<u>M</u>	<u>SD</u>	<u>N</u>	<u>Max</u>
1	9,447	5,481	34	29,888
2	6,046	5,187	14	18,005
3	11,403	20,484	39	126,070

TABLE XIX (continued)

	<u>M</u>	<u>SD</u>	<u>N</u>	<u>Max</u>
4	13,751	15,964	44	89,118
5	5,373	5,774	8	15,076
6	5,381	5,788	48	34,316
7	5,278	2,607	7	10,000
8	12,232	13,167	77	89,730
9	16,997	18,926	582	216,120

Instructional costs, from the most extensive through the least extensive objective type, ranged from objective 9 (remediation) with a mean cost of \$16,997 per project to objective 4 (special education) with \$13,751. These two extremes were followed by curriculum expansion (objective 8) with a mean cost of \$12,232 to objective 3 (class reduction) with a mean of \$11,403, to the practical arts (objective 1) with a mean of \$9,447. Health services, preschool-kindergarten enrichment, guidance-counseling-social work, and dropout objectives all bunched at \$5,000 to \$6,000 range.

The maximum project grant by objective type also occurred under objective 9 with \$216,120 being spent. Class reduction showed the next largest maximum project grant, that of \$126,070; while both curriculum expansion and special education followed with project grants in the neighborhood of \$89,000 at a maximum.

Stated another way, when instructional costs are compared

with objective types, remediation was the most costly of the objectives listed. Special education, curriculum expansion and class reduction followed very closely and represented the second category of expense. If one were looking for the least expensive objective in terms of the instructional costs related, dropout problem type objective with a mean expenditure of \$5,278 for the seven projects listed would be where the funds would be expended.

Salaries by Objective Type

The largest proportion of instructional costs goes into salaries. When objective type and salary are compared, as in Table XX, one finds that again remediation (objective 9) had the largest mean salary figure. The figure for remediation (\$7,992 as a mean) represented the largest salary figure shown as well as the largest number of projects reporting salary figures. The least expensive objective in terms of the salaries listed was that of practical arts. The mean salary figure for practical arts was \$2,200. The more frequently listed projects - those representing 50 or above but excluding remediation - showed a salary figure in the range of \$4,000 to \$5,000. Curriculum expansion, with 77 projects listing this as an objective, had a mean salary figure of \$3,554.

TABLE XX

SALARIES PER PROJECT BY OBJECTIVE TYPE

	<u>M</u>	<u>SD</u>	<u>N</u>	<u>Max</u>
1	2, 200	2, 675	33	13, 000
2	3, 329	2, 402	38	10, 462
3	5, 117	5, 411	50	26, 732
4	5, 426	5, 530	50	23, 151
5	5, 758	5, 813	23	27, 740
6	4, 210	3, 808	52	18, 700
7	2, 728	1, 943	6	5, 498
8	3, 554	6, 501	77	51, 905
9	7, 992	9, 385	640	119, 350

When the emphasis is placed on the achievement of objectives as a relationship to the salaries expended, dropout objectives would have to be classified as both the least frequently stated, with a project N of 6, and the lowest maximum expenditure with the figure \$5, 498 shown. The second lowest in terms of maximum was health services while the lowest in terms of mean salary was the figure reported for the preactical arts. Remediation again topped the list both in terms of maximum salaries and number of projects.

Teacher Additions by Objective Type

The previously presented figures on salaries become more meaningful when examined as the number of teacher additions provided by

objective categories. When the number of teacher additions by SMSA level (shown as Table VIII of Part I) is compared with the teacher additions per project by objective type (shown as Table XXI below) a fresh perspective is added to the instructional cost figures.

Table XXI showed a range of 1.4 additions for the health services objective class through 4.4 additions for remediation objectives as mean numbers of teacher additions. In terms of a maximum, the same two objectives (2 and 9) also represented the range. Objective 2 had a maximum teacher addition of 2 and objective 9 had a maximum teacher addition of 88.

TABLE XXI
NUMBER OF TEACHER ADDITIONS PER PROJECT
BY OBJECTIVE TYPE

	<u>M</u>	<u>SD</u>	<u>N</u>	<u>Max</u>
1	1.8	2.7	26	15.0
2	1.4	0.5	5	2.0
3	2.4	2.7	31	13.0
4	1.7	1.4	43	8.0
5	1.5	0.8	6	3.0
6	3.1	4.6	48	29.0
7	2.0	1.3	5	4.0
8	2.7	4.9	50	33.0
9	4.4	6.1	609	88.0

The teacher additions listed for remediation, in addition to the highest mean figure, also had the highest standard deviation, and represented far and away the largest number of projects by objective type. The 609 projects stating remediation as a function of teacher addition to the staff, contrasted to the next highest figure of project objectives, curriculum expansion, which had 50 projects listed.

Administrative Additions by Objective Type

When administrative additions were classified by objective type, the most salient finding was that approximately one-third of the projects classified an administrative addition as a function of their projects.

Table XXII summarizes the relationship between administrative additions and objectives. It should be noted that the mean figure across all nine objective types was less than two and exactly one for six of the nine objectives stated.

TABLE XXII
NUMBER OF ADMINISTRATIVE ADDITIONS PER PROJECT
BY OBJECTIVE TYPE

	<u>M</u>	<u>SD</u>	<u>N</u>	<u>Max</u>
1	1.0	0.0	11	1.0
2	1.3	0.4	11	2.0
3	1.3	0.7	7	3.0
4	1.0	0.0	9	1.0
5	1.0	0.0	3	1.0

TABLE XXII (continued)

	<u>M</u>	<u>SD</u>	<u>N</u>	<u>Max</u>
6	1.0	0.0	27	1.0
7	1.0	0.0	1	1.0
8	1.0	0.0	19	1.0
9	1.2	0.5	274	4.0

In terms of the maximum number of administrative additions shown, objective 9 (remediation) had a maximum project allocation of 4. This was followed by the objective class reduction with a maximum of 3. The only other objective listing a maximum of more than 1 was that of health services in which the maximum number listed was 2.

When the relationship between the number of administrative additions and the number of teacher additions is compared in terms of project objectives, both the number of projects reporting administrative additions and the mean number of administrative additions present a clear picture of the fact that teacher additions far outnumbered administrative additions in carrying out the mandates of Title I programs; again, pointing out the previously shown favorable relationship in teacher/administrative positions across projects.

Consultant Additions by Objective Type

In carrying out the nine objectives listed, the projects tended not to use consultant services. But, those projects which employed consultants tended to use more multiple consultants for their projects.

Table XXIII, a breakout of consultant additions by project objectives, showed that only one objective, i. e., that of health services, showed a maximum figure of one consultant. All other objectives showed a maximum number greater than one for consultant additions when classified by project.

TABLE XXIII
NUMBER OF CONSULTANT ADDITIONS PER PROJECT
BY OBJECTIVE TYPE

	<u>M</u>	<u>SD</u>	<u>N</u>	<u>Max</u>
1	1.4	0.8	5	3.0
2	1.0	0.0	4	1.0
3	2.7	2.4	3	6.0
4	1.4	0.9	10	4.0
5	2.1	2.3	18	11.0
6	1.3	0.7	24	3.0
7	1.4	0.5	5	2.0
8	3.3	5.4	12	20.0
9	1.3	0.8	111	5.0

It was rather disappointing that a relatively small proportion of the total projects employed consultants. But, at the same time, it was also heartening to see that those projects which did employ consultants tended to employ multiple consultants.

Here again we find the remediation projects showing the maximum use of consultant services. Surprisingly, curriculum expansion projects tended to employ a maximum number when examined on a per project basis. In other words, where the curriculum was expanded, it tended to be expanded in multiple directions. This objective also showed the largest mean number of consultant additions. Class reduction, the second most frequent user of consultants in terms of mean number, closely followed curriculum expansion in its use of consultants with a mean of 2.7.

In-Service Training Expenditures by Objective Type

Table XXIV showed the relationship between objective type and in-service training expenditures. The highest in-service training cost was incurred for objectives related to curriculum expansion. The mean amount for the seven projects in this category was \$3,807. This expenditure was followed by the objective category remediation with \$1,506 representing the mean amount for the 134 projects.

TABLE XXIV

IN-SERVICE TRAINING EXPENDITURES PER PROJECT BY OBJECTIVE TYPE

	<u>M</u>	<u>SD</u>	<u>N</u>	<u>Max</u>
1	390	310	2	700
2	190	10	2	200
3	992	1,188	5	3,310

TABLE XXIV (continued)

	<u>M</u>	<u>SD</u>	<u>N</u>	<u>Max</u>
4	991	1,741	16	5,634
5	18	0	1	18
6	382	252	18	1,000
7	100	0	1	100
8	3,807	6,364	7	18,140
9	1,506	4,613	134	33,927

It should be noted that in-service training was carried out by very few of the total projects when classified by objective type. The only activity less frequently represented was that of consultant additions. The maximum expenditure was that of \$33,927 listed under the remediation objective in-service training.

Perhaps the most significant feature of this table was the fact that objective 5 (guidance counseling and social work) coupled with objective 7 (dropouts) only reported one project in each category and represented a total expenditure of only \$118 for in-service training costs.

Supporting Services by Objective Type

Table XXV, which relates supporting services expenditures, and objective categories, shows supporting services classified as project objective expenditures. Health services represented the largest mean expenditure as a supporting service. For the 26 projects

listing health services objectives, a mean figure of \$5,297 was expended. The maximum grant for supporting services also occurred under health services. The grant was for \$21,945.

TABLE XXV
SUPPORTING SERVICES EXPENDITURES PER PROJECT
BY OBJECTIVE TYPE

	<u>M</u>	<u>SD</u>	<u>N</u>	<u>Max</u>
1	2,622	2,921	4	7,269
2	5,297	4,747	26	21,945
3	894	575	7	1,635
4	1,133	1,567	17	5,487
5	2,094	2,700	7	7,640
6	1,633	2,560	37	13,360
7	2,080	1,471	3	4,160
8	4,038	5,574	13	16,870
9	2,203	2,800	166	21,018

Objective 9 (remediation) had the largest number of projects listing supporting services expenditures with 166 such projects shown. But, at the same time, this objective category represented the fourth highest mean expenditure - that of \$2,203. The per project cost for the most frequent user of supporting services (remediation) tended toward the average in mean per project cost.

Class reduction, when listed as an objective, showed the smallest

mean expenditure for supporting services. In other words, when class reduction was stated as an objective, the tendency was to expend little money for the supporting services function.

Other Educational Services by Objective

Table XXVI shows the relationship between the nine classified objective categories and the expenditures for "Other Educational Services." Here we find that objective 5 tended to expend, relative to the other objectives, the largest portion of monies as other educational expenditures. For the 17 guidance type projects, a mean of \$7,817 was expended. This same objective (objective 5) also represented the largest maximum project amount for other educational services.

TABLE XXVI

OTHER ED. SERVICES EXPENDITURES PER PROJECT BY OBJECTIVE TYPE

	<u>M</u>	<u>SD</u>	<u>N</u>	<u>Max</u>
1	743	779	4	2,050
2	2,748	1,883	6	5,400
3	2,554	0	1	2,554
4	3,149	2,294	13	6,462
5	7,817	9,243	17	40,600
6	1,187	1,367	20	5,353
7	3,450	0	1	3,450
8	2,530	3,395	4	8,333
9	2,064	3,276	78	20,000

The objective related to dropout type projects (objective 7) showed the next highest mean expenditure. It should be pointed out that this figure was still less than half the mean expenditure for guidance objectives. Also, only one project listed an "other educational expenditure" under the dropout objective. This expenditure, that of \$3,450, when presented as a mean dollar amount is rather deceptive. For example, remediation (objective 9) showed a maximum grant of \$20,000; but this objective was listed for 78 projects and the mean amount was \$2,064. The only other objective for a single project was that of class reduction which showed an expenditure for other educational services of \$2,554.

In summarizing this table, one would be quickly led to the conclusion that guidance counseling and social work (objective 5) represented the largest mean expenditure and also the largest maximum expenditure for other educational services. This is perhaps a better indication of guidance involvement than that shown under in-service training in Table XXIV. There you will remember only one project with an expenditure of \$18 was listed.

Health Services Staff Additions by Objective Type

When the objective types were compared with the number of health service staff additions, Table XXVII resulted. Two of the objectives - practical arts (objective 1) and dropout programs (objective 7) were not represented by health service staff additions.

TABLE XXVII

NUMBER OF HEALTH SERVICE STAFF ADDITIONS PER PROJECT
BY OBJECTIVE TYPE

	<u>M</u>	<u>SD</u>	<u>N</u>	<u>Max</u>
1	0.0	0.0	0	0.0
2	1.2	0.7	34	4.0
3	1.0	0.0	6	1.0
4	1.0	0.0	7	1.0
5	1.0	0.0	3	1.0
6	1.1	0.3	29	2.0
7	0.0	0.0	0	0.0
8	1.3	0.4	4	2.0
9	1.1	0.3	110	3.0

The maximum number of health service additions occurred under objective 2 (health services). Interestingly enough, objective 9 (remediation) showed a maximum of three health service staff additions for a single project and also 110 projects listed staff members under this category. The mean number of additions across all categories that created staff additions by project objective was close to one.

It would be safe to say that health service staff additions were not one of the more dominant project features in terms of expenditure when classified by objective type. This was also true when health service additions were examined by SMSA levels in Table XIV of Part I.

There we found that SMSA level B had no health service additions listed.

Teacher Aid Additions by Objective Type

The use of teacher aids in the projects, when classified by objective type, is shown in Table XXVIII. This table demonstrates the frequency of teacher aids in the projects. The use of teacher aids was greatest for projects having the objective of remediation (objective 9) with 225 projects thus categorized. Objective 7, the objective related to dropout projects, did not include teacher aid additions as a function of their projects. Guidance-counseling-social work showed only one project involving teacher aid additions.

TABLE XXVIII

NUMBER OF TEACHER AID ADDITIONS PER PROJECT BY OBJECTIVE TYPE

	<u>M</u>	<u>SD</u>	<u>N</u>	<u>Max</u>
1	1.0	0.0	5	1.0
2	1.5	0.5	2	2.0
3	3.9	4.0	27	15.0
4	2.1	2.2	13	9.0
5	1.0	0.0	1	1.0
6	3.2	4.8	32	26.0
7	0.0	0.0	0	0.0
8	1.8	1.3	27	6.0
9	2.7	2.9	225	22.0

When these figures are related to those of Table XXV in Section I, it can be seen that the use of teacher aids was also a function of all SMSA levels and represented the kind of relationship that Title I hoped to achieve. Again, Table XXVIII demonstrated that teacher aids were an integral function of project objectives.

Stated another way, in relation to seven of the nine objectives, teacher aids were employed to achieve the objective. One would expect that this employment allowed the teacher responsible for achieving the particular objective to function in a more direct manner and spend less time with the kinds of clerical tasks a teacher aid typically assumes.

Other Staff Additions by Objective Type

Table XXIX, the relationship between other staff additions per project and objective types, shows that this category was used very infrequently in terms of objective type. For example, only 36 projects employed other staff additions. Of that number, 26 were related to objective 9 (remediation).

TABLE XXIX
NUMBER OF OTHER STAFF ADDITIONS PER PROJECT
BY OBJECTIVE TYPE

	<u>M</u>	<u>SD</u>	<u>N</u>	<u>Max</u>
1	1.5	0.5	2	2.0
2	0.0	0.0	0	0.0
3	0.0	0.0	0	0.0

TABLE XXIX (continued)

	<u>M</u>	<u>SD</u>	<u>N</u>	<u>Max</u>
4	1.0	0.0	5	1.0
5	0.0	0.0	0	0.0
6	1.0	0.0	3	1.0
7	0.0	0.0	0	0.0
8	0.0	0.0	0	0.0
9	2.0	2.4	26	10.0

The maximum number of other staff additions also occurred under objective 9. One project classified by this objective reported 10 other staff additions. Considering that the use of other staff members was kept at a minimum, one would be led to believe that the clerical and additional work involved in providing for compensatory education either did not necessitate an increase in staff members who were not related to the instructional program, or that the tasks were assumed under the existing structure.

It was, in fact, the objectives which had to do with providing for remediation, enrichment, special education, and practical arts that led to the only representation of the category "other staff additions." The table represents a significant finding in terms of the disbursement of staff, i.e., non-professional staff, in relation to the stated objectives of the projects included under Title I funding.

Remodeling Expenditures by Objective Type

Table XXX, the last of the tables showing the cross-break of the relationship between expenditure and objective type, shows that some Title I monies were expended for remodeling purposes. It is significant to note that 48 of the 51 projects listing remodeling expenditures fell into just three of the objective categories.

TABLE XXX
REMODELING EXPENDITURES PER PROJECT
BY OBJECTIVE TYPE

	<u>M</u>	<u>SD</u>	<u>N</u>	<u>Max</u>
1	1, 000	0	1	1, 000
2	296	0	1	296
3	90, 000	0	1	90, 000
4	13, 150	21, 456	9	70, 352
5	0	0	0	0
6	0	0	0	0
7	0	0	0	0
8	1, 823	1, 365	4	3, 990
9	5, 565	7, 142	35	33, 000

Objective 9 (remediation) showed by far the largest portion of remodeling expenditures with 35 projects reporting this expenditure. Class reduction (objective 3) showed 1 project using Title I monies

for remodeling to the extent of \$90,000. Objective 4 (special education) provided a maximum of \$70,352 for remodeling purposes. There were 9 projects spending Title I monies for remodeling under the objective special education and the mean expenditure was \$13,150.

Curriculum expansion (objective 8) showed 4 projects spending money for remodeling purposes. The maximum grant was \$3,990 and the mean amount spent was \$1,823. One could expect that curriculum expansion would have some (if only slight) relationship to remodeling expenditures.

Perhaps the most significant feature of this table was the fact that 1 project used the objective of class reduction and spent \$90,000 for remodeling expenditure. They built classroom spaces. When related to the amount of money spent for Title I purposes in the state (\$15,445,609) the extent to which the money was used for remodeling purposes was indeed small.

ABILITY, ACHIEVEMENT AND OTHER FACTOR CODES

This section of the report will deal with the twenty-four ability codes used in making application for Title I funds. The complete listing of the frequency of use of all twenty-four codes by SMSA level may be found in Appendix A.

In the body of this report the ability codes were summarized as the eight most frequently reported tests and a category for other tests. It was felt that this summarization would lead to a better understanding of the frequency of use of particular ability tests as a means of assigning Title I project participants within the State of Iowa. The tables which summarize these data follow and are a part of the narrative report. The sequencing of the tables is such that the ability code tables are presented first, the achievement tables and explanation follow, and the other factor code table summaries are presented last.

Ability Codes

The condensed ability code table by grade level for the elementary Title I population (Table XXXI) is presented first in terms of total usage for boys and girls combined, followed by Table XXXII showing the distribution of boys only. This table is followed by Table XXXIII showing the same classification for girls. Then, the boy-girl classification is further divided into boys who have actually entered projects (Table XXXIV) as contrasted to those who did not

TABLE XXXI

82

CONDENSED ABILITY CODES BY GRADE
Total Boys & Girls (Elementary)

Code	Grade							Total
	K	1	2	3	4	5	6	
3	4	41	55	206	332	353	129	1120
RP*	0.4	3.7	4.9	18.4	29.6	31.5	11.5	
CP	0.7	2.1	2.3	5.8	6.6	6.8	10.1	
TP	0.0	0.2	0.3	1.0	1.7	1.8	0.6	5.6
4	4	39	158	274	424	434	88	1421
RP	0.3	2.7	11.1	19.3	29.8	30.5	6.2	
CP	0.7	2.0	6.6	7.7	8.5	8.3	6.9	
TP	0.0	0.2	0.8	1.4	2.1	2.2	0.4	7.1
8	9	13	27	135	270	178	59	691
RP	1.3	1.9	3.9	19.5	39.1	25.8	8.5	
CP	1.7	0.7	1.1	3.8	5.4	3.4	4.6	
TP	0.0	0.1	0.1	0.7	1.4	0.9	0.3	3.5
9	1	158	261	423	429	489	91	1852
RP	0.1	8.5	14.1	22.8	23.2	26.4	4.9	
CP	0.2	8.2	10.9	11.9	8.6	9.4	7.1	
TP	0.0	0.8	1.3	2.1	2.2	2.5	0.5	9.3
11	121	270	402	579	574	660	98	2704
RP	0.4	10.0	14.9	21.4	21.2	24.4	3.6	
CP	22.7	14.0	16.8	16.3	11.5	12.6	7.7	
TP	0.6	1.4	2.0	2.9	2.9	3.3	0.5	13.6
14	14	248	461	1191	2173	2178	651	6916
RP	0.2	3.6	6.7	17.2	31.4	31.5	9.4	
CP	2.6	12.9	19.3	33.5	43.4	41.7	51.1	
TP	0.1	1.2	2.3	6.0	10.9	10.9	3.3	34.7
OTHER	381	1158	1028	744	804	935	159	5209
RP	7.3	22.2	19.7	14.3	15.4	17.9	3.1	
CP	71.3	60.1	43.0	20.9	16.1	17.9	12.5	
TP	1.9	5.8	5.2	3.7	4.0	4.7	0.8	26.2
TOTAL	534	1927	2392	3552	5006	5227	1275	19913
TP	2.7	9.7	12.0	17.8	25.1	26.2	6.4	

*RP stands for the percent N is of the row; CP, of the column; and TP, of the total.

CONDENSED ABILITY CODES BY GRADE
Total Boys (Elementary)

Code	Grade							Total
	K	1	2	3	4	5	6	
3	4	27	36	133	194	215	81	690
RP*	0.6	3.9	5.2	19.3	28.1	31.2	11.7	
CP	1.2	2.2	2.3	5.9	6.4	6.8	10.8	
TP	0.0	0.2	0.3	1.1	1.6	1.7	0.6	5.6
4	2	25	96	185	262	257	51	878
RP	0.2	2.8	10.9	21.1	29.8	29.3	5.8	
CP	0.6	2.1	6.2	8.2	8.6	8.1	6.8	
TP	0.0	0.2	0.8	1.5	2.1	2.1	0.4	7.1
8	6	7	13	81	155	109	35	406
RP	1.5	1.7	3.2	20.0	38.2	26.8	8.6	
CP	1.8	0.6	0.8	3.6	5.1	3.4	4.7	
TP	0.0	0.0	0.1	0.7	1.3	0.9	0.3	3.3
9	1	101	172	255	271	295	54	1149
RP	0.1	8.8	15.0	22.2	23.6	25.7	4.7	
CP	0.3	8.3	11.2	11.3	8.9	9.3	7.2	
TP	0.0	0.8	1.4	2.1	2.2	2.4	0.4	9.3
11	75	166	260	356	349	397	56	1659
RP	4.5	10.0	15.7	21.5	21.0	24.0	3.4	
CP	22.1	13.6	17.0	15.8	11.4	12.5	7.5	
TP	0.6	1.3	2.1	2.9	2.8	3.2	0.4	13.4
14	10	151	294	763	1310	1309	371	4208
RP	0.0	3.6	7.0	18.1	31.1	31.1	8.8	
CP	2.9	12.4	19.1	33.8	42.9	41.4	49.5	
TP	0.1	1.2	2.4	6.2	0.1	0.1	3.0	34.2
OTHER	242	742	666	487	511	582	101	3331
RP	7.3	22.3	20.0	14.6	15.3	17.5	3.0	
CP	71.2	61.3	43.3	21.5	16.7	18.4	13.5	
TP	2.0	6.0	5.4	4.0	4.1	4.7	0.8	27.0
TOTAL	340	1219	1537	2260	3052	3164	749	12321
TP	2.8	9.9	12.5	18.3	24.8	25.7	6.1	

*RP stands for the percent N is of the row; CP, of the column; TP, of the total.

TABLE XXXIII

CONDENSED ABILITY CODES BY GRADE
Total Girls (Elementary)

Code	Grade							Total
	K	1	2	3	4	5	6	
3	0	14	19	73	138	138	48	430
RP*	0.0	3.3	4.4	17.0	32.1	32.1	11.2	
CP	0.0	2.0	2.2	5.7	7.1	6.7	9.1	
TP	0.0	0.2	0.2	0.9	1.8	1.8	0.6	5.7
4	2	14	62	89	162	177	37	543
RP	0.4	2.6	11.4	16.4	29.8	32.6	6.8	
CP	1.0	2.0	7.3	6.9	8.3	8.6	7.0	
TP	0.0	0.2	0.8	1.2	2.1	2.3	0.5	7.2
8	3	6	14	54	115	69	24	285
RP	1.1	2.1	4.9	19.0	40.4	24.2	8.4	
CP	1.5	0.8	1.6	4.2	5.9	3.3	4.6	
TP	0.0	0.1	0.2	0.7	1.5	0.9	0.3	3.8
9	0	57	89	168	158	194	37	703
RP	0.0	8.1	12.7	23.9	22.5	27.6	5.3	
CP	0.0	8.1	10.4	13.0	8.1	9.4	7.0	
TP	0.0	0.8	1.2	2.2	2.1	2.6	0.5	9.3
11	46	104	142	223	225	263	42	1045
RP	4.4	9.9	13.6	21.3	21.5	25.2	4.0	
CP	23.7	14.7	16.6	17.3	11.5	12.7	8.0	
TP	0.6	1.4	1.9	2.9	3.0	3.5	0.6	13.8
14	4	97	167	428	863	869	280	2708
RP	0.1	3.6	6.2	15.8	31.9	32.1	10.3	
CP	2.1	13.7	19.5	33.1	44.2	42.1	53.2	
TP	0.1	1.3	2.2	5.6	11.4	11.4	3.7	35.7
OTHER	139	416	362	257	293	353	58	1878
RP	7.4	22.2	19.3	13.7	15.6	18.8	3.1	
CP	71.6	58.8	42.3	19.9	15.0	17.1	11.0	
TP	1.8	5.5	4.8	3.4	3.9	4.6	0.8	24.7
TOTAL	194	708	855	1292	1954	2063	526	7592
TP	2.6	9.3	11.3	17.0	25.7	27.2	6.9	

*RP stands for the percent N is of the row; CP, of the column; and TP, of the total.

TABLE XXXIV

85

CONDENSED ABILITY CODES BY GRADE
Boys in Project (Elementary)

Code	Grade							Total
	K	1	2	3	4	5	6	
3	3	14	28	98	147	132	58	480
RP*	0.6	2.9	5.8	20.4	30.6	27.5	12.1	
CP	1.2	1.5	2.3	5.4	5.8	5.1	10.4	
TP	0.0	0.1	0.3	1.0	1.5	1.3	0.6	4.8
4	1	25	73	159	212	224	41	735
RP	0.1	3.4	9.9	21.6	28.8	30.5	5.6	
CP	0.4	2.7	5.9	8.7	8.3	8.7	7.3	
TP	0.0	0.3	0.7	1.6	2.1	2.3	0.4	7.4
8	1	3	10	55	129	77	19	294
RP	0.3	1.0	3.4	18.7	43.9	26.2	6.5	
CP	0.4	0.3	0.8	3.0	5.1	3.0	3.4	
TP	0.0	0.0	0.1	0.6	1.3	0.8	0.2	3.0
9	1	87	134	191	242	222	43	920
RP	0.1	9.5	14.6	20.8	26.3	24.1	4.7	
CP	0.4	9.3	10.9	10.4	9.5	8.6	7.7	
TP	0.0	0.9	1.4	1.9	2.4	2.2	0.4	9.3
11	74	139	223	277	297	332	49	1391
RP	5.3	10.0	16.0	19.9	21.4	23.9	3.5	
CP	30.5	14.9	18.2	15.1	11.6	12.9	8.7	
TP	0.7	1.4	2.2	2.8	3.0	3.3	0.5	14.0
14	4	100	221	643	1094	1093	276	3431
RP	0.1	2.9	6.4	18.7	31.9	31.9	8.0	
CP	1.6	10.7	18.0	35.2	42.9	42.6	49.3	
TP	0.0	1.0	2.2	6.5	11.0	11.0	2.8	34.6
OTHER	159	568	539	406	430	488	74	2664
RP	6.0	21.3	20.2	15.2	16.1	18.3	2.8	
CP	65.4	60.7	43.9	22.2	16.9	19.0	13.2	
TP	1.6	5.7	5.4	4.1	4.3	4.9	0.7	26.9
TOTAL	243	936	1228	1829	2551	2568	560	9915
TP	2.5	9.4	12.4	18.4	25.7	25.9	5.6	

*RP stands for the percent N is of the row; CP, of the column; and TP, of the total.

(Table XXXV) and likewise, girls who actually entered projects (Table XXXVI) as contrasted with those who did not (Table XXXVII). The condensed ability codes for the secondary level follow the same structure and are presented in exactly the same way in Tables XXXVII through XLIV.

The condensed ability codes shown in these tables are:

Code 3	The California Short Form
Code 4	The California Test of Mental Maturity
Code 8	The Henman-Nelson Tests of Mental Ability
Code 9	Colman-Anderson Intelligence Tests
Code 11	The Lorge-Thorndyke (Verbal)
Code 14	The Otis Mental Ability Test
Other	(For example: Wechsler-Differential Aptitude Test)

From examining the above condensed ability codes, one can easily see that the type of test included in this section has to do with what we would describe as mental ability or scholastic aptitude or intelligence. The rationale for this type of testing is usually considered to rest in the prediction of future scholastic achievement. The tests themselves are used in education primarily for judging readiness for, and ability to perform at, a given level once a child is within school.

Turning to the tables themselves, they indicate that the most popular ability measure used to assign both elementary and secondary pupils to Title I projects in Iowa was the Otis Mental Ability Test. At

TABLE XXXV

CONDENSED ABILITY CODES BY GRADE
Boys Not in Project (Elementary)

Code	Grade							Total
	K	1	2	3	4	5	6	
3	1	13	8	35	47	83	23	210
RP*	0.5	6.2	3.8	16.7	22.4	39.5	10.9	
CP	1.0	4.6	2.6	8.1	9.4	13.9	12.2	
TP	0.0	0.5	0.3	1.5	2.0	3.4	1.0	8.7
4	1	0	23	26	50	33	10	143
RP	0.7	0.0	16.0	18.2	34.9	23.0	7.0	
CP	1.0	0.0	7.4	6.0	10.0	5.5	5.3	
TP	0.0	0.0	1.0	1.1	2.1	1.4	0.4	5.9
8	5	4	3	26	26	32	16	112
RP	4.5	3.6	2.7	23.2	23.2	28.6	14.2	
CP	5.2	1.4	1.0	6.0	5.2	5.4	8.5	
TP	0.2	0.2	0.1	1.1	1.1	1.3	0.7	4.7
9	0	14	38	64	29	73	11	229
RP	0.0	6.1	16.6	27.9	12.6	31.9	4.8	
CP	0.0	4.9	12.3	14.8	5.8	12.2	5.8	
TP	0.0	0.6	1.6	2.7	1.2	3.0	0.5	9.5
11	1	27	37	79	52	65	7	268
RP	0.4	10.1	13.9	29.5	19.4	24.2	2.6	
CP	1.0	9.5	12.0	18.3	10.4	10.9	3.7	
TP	0.0	1.1	1.5	3.3	2.2	2.7	0.3	11.1
14	6	51	73	120	216	216	95	777
RP	0.7	6.6	9.4	15.4	27.8	27.8	12.2	
CP	6.2	18.0	23.6	27.8	43.1	36.2	50.3	
TP	0.2	2.1	3.0	5.0	9.0	9.0	3.9	32.3
OTHER	83	174	127	81	81	94	27	667
RP	12.4	26.1	19.0	12.1	12.1	14.1	4.0	
CP	85.6	61.5	41.1	18.8	16.2	15.8	14.3	
TP	3.4	7.2	5.3	3.4	3.4	3.9	1.1	27.7
TOTAL	97	283	309	431	501	596	189	2406
TP	4.0	11.8	12.8	17.9	20.8	24.8	7.9	

*RP stands for the percent N is of the row; CP, of the column; and TP, of the total.

TABLE XXXVI

CONDENSED ABILITY CODES BY GRADE
Girls in Project (Elementary)

Code	Grade							Total
	K	1	2	3	4	5	6	
3	0	10	12	41	83	88	34	268
RP*	0.0	3.7	4.5	15.3	30.9	32.8	12.7	
CP	0.0	1.8	1.9	4.0	5.3	5.3	8.6	
TP	0.0	0.2	0.2	0.7	1.4	1.5	0.6	4.5
4	1	14	43	77	141	152	34	462
RP	0.2	3.0	9.3	16.7	30.5	32.9	7.4	
CP	0.7	2.6	6.7	7.6	8.9	9.2	8.6	
TP	0.0	0.2	0.7	1.3	2.4	2.5	0.6	7.7
8	0	4	11	40	85	46	17	203
RP	0.0	2.0	5.4	19.7	41.9	22.7	8.3	
CP	0.0	0.7	1.7	3.9	5.4	2.8	4.3	
TP	0.0	0.1	0.2	0.7	1.4	0.8	0.3	3.4
9	0	48	64	122	135	147	29	545
RP	0.0	8.8	11.7	22.4	24.8	27.0	5.3	
CP	0.0	8.7	10.0	12.0	8.5	8.9	7.3	
TP	0.0	0.8	1.1	2.0	2.3	2.5	0.5	9.1
11	46	90	118	161	180	211	34	840
RP	5.5	10.7	14.0	19.2	21.4	25.1	4.0	
CP	34.3	16.4	18.4	15.8	11.4	12.8	8.6	
TP	0.8	1.5	2.0	2.7	3.0	3.5	0.6	14.1
14	2	77	117	352	718	725	206	2197
RP	0.1	3.5	5.3	16.0	32.7	33.0	9.4	
CP	1.5	14.0	18.3	34.6	45.5	43.9	51.9	
TP	0.0	1.3	2.0	5.9	12.0	12.1	3.5	36.8
OTHER	85	306	276	225	237	281	43	1453
RP	5.8	21.1	19.0	15.5	16.3	19.3	3.0	
CP	63.4	55.7	43.1	22.1	15.0	17.0	10.8	
TP	1.4	5.1	4.6	3.8	4.0	4.7	0.7	24.3
TOTAL	134	549	641	1018	1579	1650	397	5968
TP	2.2	9.2	10.7	17.1	26.5	27.6	6.7	

*RP stands for the percent N is of the row; CP, of the column; and TP, of the total.

CONDENSED ABILITY CODES BY GRADE
Girls Not in Project (Elementary)

Code	Grade							Total
	K	1	2	3	4	5	6	
3	0	4	7	32	55	50	14	162
RP*	0.0	2.5	4.3	19.8	34.0	30.9	8.6	
CP	0.0	2.5	3.3	11.7	14.7	12.1	10.9	
TP	0.0	0.2	0.4	2.0	3.4	3.1	0.9	10.0
4	1	0	19	12	21	25	3	81
RP	1.2	0.0	23.5	14.8	25.9	30.9	3.7	
CP	1.7	0.0	8.9	4.4	5.6	6.1	3.0	
TP	0.1	0.0	1.2	0.7	1.3	1.5	0.0	5.0
8	3	2	3	14	30	23	7	82
RP	3.7	2.4	3.7	17.1	36.6	28.0	8.5	
CP	5.0	1.3	1.4	5.1	8.0	5.6	5.4	
TP	0.2	0.1	0.2	0.9	1.8	1.4	0.4	5.0
9	0	9	25	46	23	47	8	158
RP	0.0	5.7	15.9	29.1	14.6	29.7	5.0	
CP	0.0	5.7	11.7	16.8	6.1	11.4	6.2	
TP	0.0	0.6	1.5	2.8	1.4	2.9	0.5	9.7
11	0	14	24	62	45	52	8	205
RP	0.0	6.8	11.7	30.2	22.0	25.4	3.9	
CP	0.0	8.8	11.2	22.6	12.0	12.6	6.2	
TP	0.0	0.9	1.5	3.8	2.8	3.2	0.5	12.6
14	2	20	50	76	145	144	74	511
RP	0.4	4.0	9.8	14.9	28.4	28.2	14.5	
CP	3.3	12.6	23.4	27.7	38.7	34.9	57.4	
TP	0.1	1.2	3.1	4.7	8.9	8.9	4.6	31.5
OTHER	54	110	86	32	56	72	15	425
RP	12.7	25.9	20.2	7.5	13.2	16.9	3.5	
CP	90.0	69.2	40.2	11.7	14.9	17.4	11.6	
TP	3.3	6.8	5.3	2.0	3.4	4.4	0.9	26.2
TOTAL	60	159	214	274	375	413	129	1624
TP	3.7	9.8	13.2	16.9	23.1	25.4	7.9	

*RP stands for the percent N is of the row; CP, of the column; TP, of the total.

TABLE XXXVIII

CONDENSED ABILITY CODES BY GRADE
Total Boys and Girls (Secondary)

Code	Grade						Total
	7	8	9	10	11	12	
3	394	410	367	348	257	134	1910
RP*	20.6	21.5	19.2	18.2	13.5	7.0	
CP	9.2	9.0	5.9	6.1	5.2	3.5	
TP	1.3	1.4	1.2	1.2	0.9	0.5	6.5
4	378	452	743	492	464	367	2896
RP	13.1	15.6	25.7	17.0	16.0	12.7	
CP	8.9	9.9	11.9	8.6	9.4	9.5	
TP	1.3	1.5	2.5	1.7	1.6	1.2	9.8
8	244	222	322	520	433	378	2119
RP	11.5	10.5	15.2	24.5	20.4	17.8	
CP	5.7	4.9	5.2	9.1	8.7	9.8	
TP	0.8	0.7	1.1	1.8	1.5	1.3	7.2
9	343	365	473	242	218	216	1857
RP	18.5	19.7	25.5	13.0	11.7	11.6	
CP	8.0	8.0	7.6	4.2	4.4	5.6	
TP	1.2	1.2	1.6	0.8	0.7	0.7	6.3
11	511	796	1058	893	813	396	4467
RP	11.4	17.8	23.7	20.0	18.2	8.9	
CP	12.0	17.4	17.0	15.6	16.4	10.3	
TP	1.7	2.7	3.6	3.0	2.7	1.3	15.1
14	1881	1959	2583	2236	1990	1730	12379
RP	15.2	15.8	20.9	18.1	16.1	14.0	
CP	44.1	42.8	41.4	39.0	40.2	44.9	
TP	6.4	6.6	8.7	7.6	6.7	5.8	41.8
OTHER	511	372	687	1003	779	632	3984
RP	12.8	9.3	17.2	25.2	19.6	15.9	
CP	12.0	8.1	11.0	17.5	15.7	16.4	
TP	1.7	1.3	2.3	3.4	2.6	2.1	13.5
TOTAL	4262	4576	6233	5734	4954	3853	29612
TP	14.4	15.5	21.0	19.4	16.7	13.0	

*RP stands for the percent N is of the row; CP, of the column; TP, of the total.

TABLE XXXIX

CONDENSED ABILITY CODES BY GRADE
Total Boys (Secondary)

Code	Grade						Total
	7	8	9	10	11	12	
3	213	211	209	214	153	78	1078
RP*	19.8	19.6	19.4	19.9	14.2	7.2	
CP	8.4	8.1	5.8	6.5	5.3	3.5	
TP	1.2	1.2	1.2	1.2	0.9	0.5	6.3
4	222	242	431	295	285	210	1685
RP	13.2	14.4	25.6	17.5	16.9	12.5	
CP	8.8	9.3	12.0	9.0	9.9	9.4	
TP	1.3	1.4	2.5	1.7	1.7	1.2	9.8
8	134	123	206	312	271	215	1261
RP	10.6	9.8	16.3	24.7	21.5	17.0	
CP	16.3	4.7	5.7	9.5	9.4	9.6	
TP	0.8	0.7	1.2	1.8	1.6	1.2	7.4
9	200	220	258	125	107	103	1013
RP	19.7	21.7	25.5	12.3	10.6	10.2	
CP	5.3	8.4	7.2	3.8	3.7	4.6	
TP	1.2	1.3	1.5	0.7	0.6	0.6	5.9
11	303	431	623	507	464	257	2585
RP	11.7	16.7	24.1	19.6	17.9	9.9	
CP	12.0	16.5	17.4	15.5	16.0	11.5	
TP	1.8	2.5	3.6	3.0	2.7	1.5	15.1
14	1129	1166	1480	1259	1155	1021	7210
RP	15.7	16.2	20.5	17.5	16.0	14.2	
CP	44.6	44.6	41.3	38.4	39.9	45.5	
TP	6.6	6.8	8.6	7.3	6.7	6.0	42.1
OTHER	329	221	380	568	457	359	2314
RP	14.2	9.6	16.4	24.5	19.7	15.5	
CP	13.0	8.5	10.6	17.3	15.8	16.0	
TP	1.9	1.3	2.2	3.3	2.7	2.1	13.5
TOTAL	2530	2614	3587	3280	2892	2243	17146
TP	14.8	15.2	20.9	19.1	16.9	13.1	

*RP stands for the percent N is of the row; CP, of the column; TP, of the total.

TABLE XL

CONDENSED ABILITY CODES BY GRADE
Total Girls (Secondary)

Code	Grade						Total
	7	8	9	10	11	12	
3	181	199	158	134	104	56	832
RP*	21.8	23.9	19.0	16.1	12.5	6.7	
CP	10.5	10.1	6.0	5.5	5.0	3.5	
TP	1.5	1.6	1.3	1.1	0.8	0.4	6.7
4	156	210	312	197	179	157	1211
RP	12.9	17.3	25.8	16.3	14.8	13.0	
CP	9.0	10.7	11.8	8.0	8.7	9.8	
TP	1.3	1.7	2.5	1.6	1.4	1.3	9.7
8	110	99	116	208	162	163	858
RP	12.8	11.5	13.5	24.2	18.9	19.0	
CP	6.6	5.0	4.4	8.5	7.8	10.1	
TP	0.9	0.8	0.9	1.7	1.3	1.3	6.9
9	143	145	215	117	111	113	844
RP	16.9	17.2	25.5	13.9	13.2	13.4	
CP	8.3	7.4	8.1	4.8	5.4	7.0	
TP	1.1	1.2	1.7	0.9	0.9	0.9	6.8
11	208	365	435	386	349	139	1882
RP	11.1	19.4	23.1	20.5	18.5	7.4	
CP	12.0	18.6	16.5	15.7	16.9	8.6	
TP	1.7	2.9	3.5	3.1	2.8	1.1	15.1
14	752	793	1103	977	835	709	5169
RP	14.5	15.3	21.3	18.9	16.2	13.7	
CP	43.4	40.4	41.6	39.8	40.5	44.0	
TP	6.0	6.4	8.8	7.8	6.7	5.7	41.5
OTHER	182	151	307	435	322	273	1670
RP	10.9	9.0	18.4	26.0	19.3	16.3	
CP	10.5	7.7	11.6	17.7	15.6	17.0	
TP	1.5	1.2	2.5	3.5	2.6	2.2	13.4
TOTAL	1732	1962	2646	2454	2062	1610	12466
TP	13.9	15.7	21.2	19.7	16.5	12.9	

*RP stands for the percent N is of the row; CP, of the column; TP, of the total.

CONDENSED ABILITY CODES BY GRADE
Boys in Project (Secondary)

Code	Grade						Total
	7	8	9	10	11	12	
3	103	104	110	167	119	50	653
RP*	15.8	15.9	16.8	25.6	18.2	7.7	
CP	5.6	5.3	4.2	7.2	5.6	3.4	
TP	0.8	0.8	0.9	1.4	1.0	0.4	5.3
4	148	155	305	227	231	146	1212
RP	12.2	12.8	25.2	18.7	19.1	12.0	
CP	8.0	7.9	11.6	9.8	10.8	9.8	
TP	1.2	1.3	2.5	1.8	1.9	1.2	9.8
8	131	108	160	227	162	108	896
RP	14.6	12.1	17.9	25.3	18.1	12.1	
CP	7.1	5.5	6.1	9.8	7.6	7.3	
TP	1.1	0.9	1.3	1.8	1.3	0.9	7.2
9	149	153	184	87	73	70	716
RP	20.8	21.4	25.7	12.2	10.2	9.8	
CP	8.0	7.8	7.0	3.8	3.4	4.7	
TP	1.2	1.2	1.5	0.7	0.6	0.6	5.8
11	229	337	492	409	384	181	2032
RP	11.3	16.6	24.2	20.1	18.9	8.9	
CP	12.4	17.3	18.7	17.7	18.0	12.2	
TP	1.9	2.7	4.0	3.3	3.1	1.5	16.4
14	856	906	1152	859	889	745	5407
RP	15.8	16.8	21.3	15.9	16.4	13.8	
CP	46.2	46.5	43.8	37.2	41.6	50.2	
TP	6.9	7.3	9.3	6.9	7.2	6.0	43.7
OTHER	238	187	230	336	278	184	1453
RP	16.4	12.9	15.8	23.1	19.1	12.7	
CP	12.8	9.6	8.7	14.5	13.0	12.4	
TP	1.9	1.5	1.9	2.7	2.2	1.5	11.7
TOTAL	1854	1950	2633	2312	2136	1484	12369
TP	15.0	15.8	21.3	18.7	17.3	12.0	

*RP stands for the percent N is of the row; CP, of the column; TP, of the total.

TABLE XLII

CONDENSED ABILITY CODES BY GRADE
Boys Not in Project (Secondary)

Code	Grade						Total
	7	8	9	10	11	12	
3	110	107	99	47	34	28	425
RP*	25.9	25.2	23.3	11.1	8.0	6.6	
CP	16.3	16.1	10.4	4.9	4.5	3.7	
TP	2.3	2.2	2.1	1.0	0.7	0.6	8.9
4	74	87	126	68	54	64	473
RP	15.6	18.4	26.6	14.4	11.4	13.5	
CP	10.9	13.1	13.2	7.0	7.1	8.4	
TP	1.5	1.8	2.6	1.4	1.1	1.3	9.9
8	3	15	46	85	109	107	365
RP	0.8	4.1	12.6	23.3	29.9	29.3	
CP	0.4	2.3	4.8	8.8	14.4	14.1	
TP	0.0	0.3	1.0	1.8	2.3	2.2	7.6
9	51	67	74	38	34	33	297
RP	17.2	22.6	24.9	12.8	11.4	11.1	
CP	7.5	10.1	7.8	3.9	4.5	4.3	
TP	1.1	1.4	1.5	0.8	0.7	0.7	6.2
11	74	94	131	98	80	76	553
RP	13.4	17.0	23.7	17.7	14.5	13.7	
CP	10.9	14.2	13.7	10.1	10.6	10.0	
TP	1.5	2.0	2.7	2.1	1.7	1.6	11.6
14	273	260	328	400	266	276	1803
RP	15.1	14.4	18.2	22.2	14.8	15.3	
CP	40.4	39.2	34.4	41.3	35.2	36.4	
TP	5.7	5.4	6.9	8.4	5.6	5.8	37.7
OTHER	91	34	150	232	179	175	861
RP	10.6	3.9	17.4	26.9	20.8	20.3	
CP	13.5	5.1	15.7	24.0	23.7	23.1	
TP	1.9	0.7	3.1	4.9	3.7	3.7	18.0
TOTAL	676	664	954	968	756	759	4777
TP	14.2	13.9	20.0	20.3	15.8	15.9	

*RP stands for the percent N is of the row; CP, of the column; TP, of the total.

CONDENSED ABILITY CODES BY GRADE
Girls in Project (Secondary)

Code	Grade						Total
	7	8	9	10	11	12	
3	78	83	67	101	85	27	441
RP*	17.7	18.8	15.2	22.9	19.3	6.1	
CP	6.5	6.1	3.6	6.2	5.8	2.6	
TP	0.9	1.0	0.8	1.2	1.0	0.3	5.2
4	88	107	221	140	118	92	766
RP	11.5	14.0	28.9	18.3	15.4	12.1	
CP	7.4	7.8	11.7	8.5	8.1	9.0	
TP	1.0	1.3	2.6	1.6	1.4	1.1	9.0
8	110	91	95	154	109	111	670
RP	16.4	13.6	14.2	23.0	16.3	16.6	
CP	9.2	6.7	5.0	9.4	7.5	10.9	
TP	1.3	1.1	1.1	1.8	1.3	1.3	7.8
9	103	87	138	62	63	59	512
RP	20.1	17.0	27.0	12.1	12.3	11.5	
CP	8.6	6.4	7.3	3.8	4.3	5.8	
TP	1.2	1.0	1.6	0.7	0.7	0.7	6.0
11	164	287	350	308	276	94	1479
RP	11.1	19.4	23.7	20.8	18.7	6.4	
CP	13.7	21.0	18.6	18.8	19.0	9.2	
TP	1.9	3.4	4.1	3.6	3.2	1.1	17.3
14	522	582	841	657	637	513	3752
RP	13.9	15.5	22.4	17.5	17.0	13.7	
CP	43.7	42.7	44.7	40.1	43.8	50.3	
TP	6.1	6.8	9.8	7.7	7.4	6.0	43.9
OTHER	130	127	170	217	167	123	934
RP	13.9	13.6	18.2	23.2	17.9	13.2	
CP	10.9	9.3	9.0	13.2	11.5	12.1	
TP	1.5	1.5	2.0	2.5	2.0	1.4	10.9
TOTAL	1195	1364	1882	1639	1455	1019	8554
TP	14.0	16.0	22.0	19.2	17.0	11.9	

*RP stands for the percent N is of the row; CP, of the column; TP, of the total.

CONDENSED ABILITY CODES BY GRADE
Girls Not in Project (Secondary)

Code	Grade						Total
	7	8	9	10	11	12	
3	103	116	91	33	19	29	391
RP*	26.3	29.7	23.3	8.4	4.9	7.4	
CP	19.2	19.4	11.9	4.0	3.1	4.9	
TP	2.6	3.0	2.3	0.8	0.5	0.7	10.0
4	68	103	91	57	61	65	445
RP	15.3	23.1	20.4	12.8	13.7	14.6	
CP	12.7	17.2	11.9	7.0	10.0	11.0	
TP	1.7	2.6	2.3	1.5	1.6	1.7	11.4
8	0	8	21	54	53	52	188
RP	0.0	4.3	11.2	28.7	28.2	27.7	
CP	0.0	1.3	2.7	6.6	8.7	8.8	
TP	0.0	0.2	0.5	1.4	1.4	1.3	4.8
9	40	58	77	55	48	54	332
RP	12.0	17.5	23.2	16.6	14.5	16.3	
CP	7.4	9.7	10.1	6.7	7.9	9.1	
TP	1.0	1.5	2.0	1.4	1.2	1.4	8.5
11	44	78	85	78	73	45	403
RP	10.9	19.4	21.1	19.4	18.1	11.2	
CP	8.2	13.0	11.1	9.6	12.0	7.6	
TP	1.1	2.0	2.2	2.0	1.9	1.2	10.3
14	230	211	262	320	198	196	1417
RP	16.2	14.9	18.5	22.6	14.0	13.8	
CP	42.8	35.3	34.3	39.3	32.6	33.2	
TP	5.9	5.4	6.7	8.2	5.1	5.0	36.2
OTHER	52	24	137	218	155	150	736
RP	7.1	3.3	18.6	29.6	21.1	20.4	
CP	9.7	4.0	17.9	26.7	25.5	25.4	
TP	1.3	0.6	3.5	5.6	4.0	3.8	18.8
TOTAL	537	598	764	815	607	591	3912
TP	13.7	15.3	19.5	20.8	15.5	15.1	

*RP stands for the percent N is of the row; CP, of the column; TP, of the total.

the elementary level, the Otis accounted for 34.7% of the total tests used while at the secondary level it accounted for 41.8% of the total.

The use of ability testing at the elementary level was most popular at the fifth grade level. This grade level accounted for 26.2% of the total use of ability testing in the elementary schools. Fourth grade closely followed with 25.1% of the total at this grade level. Turning to the secondary school, ability testing was most popular at the ninth grade, where 21% of the pupils were assessed by this method. Grade ten closely followed with 19.4% of the total accounted for by ability testing at this grade level.

In all, 19,913 elementary school boys and girls were classified for Title I projects by the use of ability testing. At the secondary level, 29,612 boys' and girls' scores were reported under the twenty-four possible ability test codes provided.

When examining the elementary tables in terms of the total boys versus the total girls classified in Title I projects, 12,321 boys were classified by the use of ability codes where 7,592 girls were tested by ability measures. The fourth and fifth grade levels were the most popular in terms of using ability codes for classification for both boys and girls.

Again the Otis Mental Ability Tests were the most popular means of assessing ability at the elementary level. This test accounted for 34.2% of the boys tested and 35.7% of the girls. It would appear

that this closeness in percent of boys and girls would be accounted for by the fact that the test is a group test and would in all probability be given to an intact classroom containing both boys and girls. Most likely, the results of this testing served as the initial classification and it would follow that the percentage figure would be very close for boys and girls across the state at the elementary level.

When one turns to the differences between boys who were actually in projects at the elementary level versus those who were not in projects but were, in fact, identified as in need of help, the results described for the total population remain relatively constant. In other words, the Otis Mental Ability Tests again were the most frequently used measures and the popularity at the fourth and fifth grade level was again demonstrated. These results hold true when a comparison is made between girls in projects versus girls not in projects, but, in fact, identified as in need of help.

At the secondary level, when the ability codes are examined in terms of boys versus girls, the tendency that was described for the total secondary population again holds true. The ninth and tenth grades were the most popular grades for the use of ability testing to determine eligibility for Title I funding, and again the Otis was the most popular measure used.

When boys who were in projects were compared with those not in projects but classified as in need of help at the secondary level,

the ninth and tenth grade again appear as the most frequently counted grades for ability testing. Again the Otis was the most popular measure used at these grade levels. For the girls, the same results hold true as those already stated for boys at this level.

Achievement

The State Department of Public Instruction applications for Title I assistance also allowed for the reporting of standardized achievement test data as the basis for classifying pupils as eligible for Title I aid. The State Department of Public Instruction form, which paralleled the U. S. Office of Education reporting form, was the basis for this section of the report.

Achievement testing can be thought of more in terms of the relationship to actual progress made and expected progress at a particular grade level. In contrast to ability testing, achievement testing supposedly measures the relationship between what a child does in fact know and his particular grade placement at the time of testing.

The achievement test coding listed on the application allowed for ten test classifications. Appendix A shows the complete distribution by grade level within SMSA level for all ten tests. This section of the report contains a condensation of the ten possible responses into the most frequently reported measures at the elementary level and secondary level.

The summarization which follows reports the most commonly used achievement tests and also the classification "other." The coding of the tests tabled in this section follows:

Test Code 03	Iowa Tests of Basic Skills
Test Code 04	Iowa Tests of Educational Development
Test Code 05	Metropolitan Achievement Test
Test Code 06	Sequential Tests of Educational Project
Test Code 08	The Stanford Achievement Test
Test Code 10	Tests of Academic Progress

At the elementary level (Table XLV), 20,402 pupils appeared on applications with achievement test data reported. This type of test was most popular at the fourth and fifth grade level. Combined, these two grades accounted for 52.5% of the total usage of achievement testing at the elementary level. The Iowa Tests of Basic Skills were by far the most popular instrument used. These tests accounted for 51% of the total achievement testing in Iowa elementary schools. This finding was not surprising as there has been an extensive involvement at the elementary level in the Iowa Testing Program.

When the figures are presented by sex classification (Tables XLVI and XLVII) one finds that 12,570 boys and 7,832 girls were tested and classified as in need of Title I assistance using achievement measures. Again, the fourth and fifth grades appear as the most frequent grades using achievement testing for both boys and girls. The Iowa Tests of Basic Skills were used in classifying 50.3% of the boys and 52% of the girls at the elementary level.

CONDENSED ACHIEVEMENT CODES BY GRADE
Total Boys and Girls (Elementary)

Code	Grade							Total
	K	1	2	3	4	5	6	
3	7	42	54	440	3918	4775	1163	10399
RP*	0.1	0.4	0.5	4.2	37.7	45.9	11.2	
CP	2.1	1.9	2.0	14.7	77.0	84.8	76.0	
TP	0.0	0.2	0.3	2.2	19.2	23.4	5.7	51.0
5	72	799	722	576	360	56	28	2613
RP	2.8	30.6	27.6	22.0	13.8	2.1	1.1	
CP	21.9	37.0	27.0	19.3	7.1	1.0	1.8	
TP	0.4	3.9	3.5	2.8	1.8	0.3	0.2	12.8
8	0	71	426	692	369	338	162	2058
RP	0.0	3.4	20.7	33.6	17.9	16.4	7.9	
CP	0.0	3.3	16.0	23.1	7.3	6.0	10.6	
TP	0.0	0.4	2.1	3.4	1.8	1.7	0.8	10.8
10	203	1045	1182	973	304	290	77	4074
RP	5.0	25.7	29.0	23.9	7.5	7.1	1.9	
CP	61.7	48.4	44.3	32.5	6.0	5.2	5.0	
TP	1.0	5.1	5.8	4.8	1.5	1.4	0.4	20.0
OTHER	47	204	287	309	138	172	101	1258
RP	3.7	16.2	22.8	24.6	11.0	13.7	8.0	
CP	14.3	9.4	10.7	10.3	2.7	3.1	6.6	
TP	0.2	1.0	1.4	1.5	0.7	0.8	0.5	6.2
TOTAL	329	2161	2671	2990	5089	5631	1531	20402
TP	1.6	10.6	13.1	14.7	24.9	27.6	7.5	

*RP stands for the percent N is of the row; CP, of the column; TP, of the total.

CONDENSED ACHIEVEMENT CODES BY GRADE
Total Boys (Elementary)

Code	Grade							Total
	K	1	2	3	4	5	6	
3	4	26	34	293	2432	2849	688	6326
RP*	0.1	0.4	0.5	4.6	38.4	45.0	10.9	
CP	1.8	1.9	2.0	15.3	78.0	84.0	76.6	
TP	0.0	0.2	0.3	2.3	19.3	22.7	5.5	50.3
5	47	516	455	391	207	36	18	1670
RP	2.8	30.9	27.2	23.4	12.4	2.2	1.1	
CP	21.2	37.8	27.3	20.5	6.6	1.1	2.0	
TP	0.4	4.1	3.6	3.1	1.6	0.3	0.1	13.3
8	0	41	277	412	208	223	90	1251
RP	0.0	3.3	22.1	32.9	16.6	17.9	7.2	
CP	0.0	3.0	16.6	21.6	6.7	6.6	10.0	
TP	0.0	0.3	2.2	3.3	1.6	1.8	0.7	10.0
10	141	656	711	616	192	174	42	2532
RP	5.6	25.9	28.1	24.3	7.6	6.9	1.7	
CP	63.5	48.1	42.6	32.2	6.2	5.1	4.7	
TP	1.1	5.2	5.7	4.9	1.5	1.4	0.3	20.1
OTHER	30	125	192	199	77	108	60	791
RP	3.8	15.8	24.3	25.2	9.7	13.7	7.6	
CP	13.5	9.2	11.5	10.4	2.5	3.2	6.7	
TP	0.2	1.0	1.5	1.6	0.6	0.9	0.5	6.3
TOTAL	222	1364	1669	1911	3116	3390	898	12570
TP	1.8	10.9	13.3	15.2	24.8	27.0	7.1	

*RP stands for the percent N is of the row; CP, of the column; TP, of the total.

CONDENSED ACHIEVEMENT CODES BY GRADE
Total Girls (Elementary)

Code	Grade							Total
	K	1	2	3	4	5	6	
3	3	16	20	147	1486	1926	475	4073
RP*	0.1	0.4	0.5	3.6	36.5	47.3	11.7	
CP	2.8	2.0	2.0	13.6	75.3	85.9	75.0	
TP	0.0	0.2	0.3	1.9	19.0	24.6	6.1	52.0
5	25	283	267	185	153	20	10	943
RP	2.6	30.0	28.3	19.6	16.2	2.1	1.1	
CP	23.4	35.5	26.6	17.1	7.8	0.9	1.6	
TP	0.3	3.6	3.4	2.4	2.0	0.3	0.1	12.0
8	0	30	149	280	161	115	72	807
RP	0.0	3.7	18.5	34.7	20.0	14.3	8.9	
CP	0.0	3.8	14.9	25.9	8.2	5.1	11.4	
TP	0.0	0.4	1.9	3.6	2.1	1.5	0.9	10.3
10	62	389	471	357	112	116	35	1542
RP	4.0	25.2	30.5	23.2	7.3	7.5	2.3	
CP	57.9	48.8	47.0	33.1	5.7	5.1	5.5	
TP	0.8	5.0	6.0	4.6	1.4	1.5	0.4	19.7
OTHER	17	79	95	110	61	64	41	467
RP	3.6	16.9	20.3	23.6	13.1	13.7	8.8	
CP	15.9	9.9	9.5	10.2	3.1	2.9	6.5	
TP	0.2	1.0	1.2	1.4	0.8	0.8	0.5	6.0
TOTAL	107	797	1002	1079	1973	2241	633	7832
TP	1.4	10.2	12.8	13.8	25.2	28.6	8.1	

*RP stands for the percent N is of the row; CP, of the column; TP, of the total.

When a comparison is made, on the basis of achievement data, of elementary boys who are actually involved in projects (Table XLVIII) with those not in projects (Table XLIX) the figures show that 10,086 boys who were in projects were classified on the basis of achievement data. In contrast, only 2,484 of the boys classified as in need of help on the basis of achievement data were not involved in projects.

The use of achievement codes for comparing elementary girls actually in projects (Table L) with girls not in projects (Table LI) showed that 6,140 of the girls tested were involved in Title I activities, while 1,692 classified as in need of Title I assistance did not enter into projects.

Since the extensive use of the Iowa Testing Program can be readily shown from an analysis of the achievement codes for the State of Iowa, a special section of this report is devoted to comparisons of pupils involved in project activities and pupils classified as in need of project help but not actually involved in Title I projects.

CONDENSED ACHIEVEMENT CODES BY GRADE
Boys in Project (Elementary)

Code	Grade							Total
	K	1	2	3	4	5	6	
3	4	16	26	220	2070	2328	509	5173
RP*	0.1	0.3	0.5	4.3	40.0	45.0	9.8	
CP	2.0	1.6	2.0	14.5	79.8	84.5	74.4	
TP	0.0	0.2	0.3	2.2	20.5	23.1	5.0	51.3
5	45	398	356	331	144	29	18	1321
RP	3.4	30.1	26.9	25.1	10.9	2.2	1.4	
CP	22.5	38.6	27.2	21.8	5.6	1.1	2.6	
TP	0.4	3.9	3.5	3.3	1.4	0.3	0.2	13.1
8	0	10	190	301	173	186	81	941
RP	0.0	1.1	20.2	32.0	18.4	19.8	8.6	
CP	0.0	1.0	14.5	19.9	6.7	6.8	11.8	
TP	0.0	0.1	1.9	3.0	1.7	1.8	0.8	9.3
10	123	500	562	504	152	148	40	2029
RP	6.1	24.6	27.7	24.8	7.5	7.3	2.0	
CP	61.5	48.5	43.0	33.2	5.9	5.4	5.8	
TP	1.2	5.0	5.6	5.0	1.5	1.5	0.4	20.1
OTHER	28	106	173	160	55	64	36	622
RP	4.5	17.0	27.8	25.7	8.8	10.3	5.8	
CP	14.0	10.3	13.2	10.6	2.1	2.3	5.3	
TP	0.3	1.1	1.7	1.6	0.5	0.6	0.4	6.2
TOTAL	200	1030	1307	1516	2594	2755	684	10086
TP	2.0	10.2	13.0	15.0	25.7	27.3	6.8	

*RP stands for the percent N is of the row; CP, of the column; TP, of the total.

CONDENSED ACHIEVEMENT CODES BY GRADE
Boys Not in Project (Elementary)

Code	Grade							Total
	K	1	2	3	4	5	6	
3	0	10	8	73	362	521	179	1153
RP*	0.0	0.9	0.7	6.3	31.4	45.2	15.5	
CP	0.0	3.0	0.2	18.5	69.3	82.0	83.6	
TP	0.0	0.4	0.3	2.9	14.6	21.0	7.2	46.4
5	2	118	99	60	63	7	0	349
RP	0.6	33.8	28.4	17.2	18.1	2.0	0.0	
CP	9.1	35.3	27.3	15.2	12.1	1.1	0.0	
TP	0.1	4.8	4.0	2.4	2.5	0.3	0.0	14.0
8	0	31	87	111	35	37	9	310
RP	0.0	10.0	28.1	35.8	11.3	11.9	2.9	
CP	0.0	9.3	24.0	28.1	6.7	5.8	4.2	
TP	0.0	1.2	3.5	4.5	1.4	1.5	0.4	12.5
10	18	156	149	112	40	26	2	503
RP	3.6	31.0	29.6	22.3	8.0	5.2	0.4	
CP	81.8	46.7	41.2	28.4	7.7	4.1	0.9	
TP	0.7	6.3	6.0	4.5	1.6	1.0	0.1	20.2
OTHER	2	19	19	39	22	44	24	169
RP	1.1	11.2	11.2	23.1	13.0	26.0	14.2	
CP	9.1	5.7	5.2	9.9	4.2	6.9	11.2	
TP	0.1	0.8	0.8	1.6	0.9	1.8	1.0	6.8
TOTAL	22	334	362	395	522	635	214	2484
TP	0.9	13.4	14.6	15.9	21.0	25.6	8.6	

*RP stands for the percent N is of the row; CP, of the column; TP, of the total.

CONDENSED ACHIEVEMENT CODES BY GRADE
Girls in Project (Elementary)

Code	Grade							Total
	K	1	2	3	4	5	6	
3	2	9	13	110	1212	1546	349	3241
RP*	0.1	0.3	0.4	3.4	37.4	47.7	10.8	
CP	2.0	1.5	1.7	13.3	76.8	85.8	72.1	
TP	0.0	0.1	0.2	1.8	19.7	25.2	5.7	52.8
5	24	219	207	155	100	14	10	729
RP	3.3	30.0	28.4	21.3	13.7	1.9	1.4	
CP	24.2	37.1	27.2	18.8	6.3	0.8	2.1	
TP	0.4	3.6	3.4	2.5	1.6	0.2	0.2	11.9
8	0	13	89	181	131	105	67	586
RP	0.0	2.2	15.2	30.9	22.4	17.9	11.4	
CP	0.0	2.2	11.7	21.9	8.3	5.8	13.8	
TP	0.0	0.2	1.4	2.9	2.1	1.7	1.1	9.5
10	56	288	373	293	89	97	34	1230
RP	4.6	23.4	30.3	23.8	7.2	7.9	2.8	
CP	56.6	48.7	49.1	35.5	5.6	5.4	7.0	
TP	0.9	4.7	6.1	4.8	1.4	1.6	0.6	20.0
OTHER	17	62	78	87	46	40	24	354
RP	4.8	17.5	22.0	24.6	13.0	11.3	6.8	
CP	17.2	10.5	10.3	10.5	2.9	2.2	5.0	
TP	0.3	1.0	1.3	1.4	0.7	0.7	0.4	5.8
TOTAL	99	591	760	826	1578	1802	484	6140
TP	1.6	9.6	12.4	13.5	25.7	29.3	7.9	

*RP stands for the percent N is of the row; CP, of the column; TP, of the total.

CONDENSED ACHIEVEMENT CODES BY GRADE
Girls Not in Project (Elementary)

Code	Grade							Total
	K	1	2	3	4	5	6	
3	1	7	7	36	274	380	126	832
RP*	0.1	0.9	0.9	4.4	32.9	45.7	15.1	
CP	12.5	3.4	2.9	14.6	69.4	86.6	84.6	
TP	0.1	0.4	0.4	2.2	16.2	22.5	7.4	49.2
5	1	64	60	30	53	6	0	214
RP	0.5	29.9	28.0	14.0	24.8	2.8	0.0	
CP	12.5	31.1	24.8	11.9	13.4	1.4	0.0	
TP	0.0	3.8	3.5	1.8	3.1	0.4	0.0	12.6
8	0	17	60	99	30	10	5	221
RP	0.0	7.7	27.1	44.8	13.6	4.5	2.3	
CP	0.0	8.3	24.8	39.1	7.6	2.3	3.4	
TP	0.0	1.0	3.5	5.9	1.8	0.6	0.3	13.1
10	6	101	98	64	23	19	1	312
RP	1.9	32.4	31.4	20.5	7.4	6.1	0.3	
CP	75.0	49.0	40.5	25.3	5.8	4.3	0.7	
TP	0.4	6.0	5.8	3.8	1.4	1.1	0.1	18.4
OTHER	0	17	17	23	15	24	17	113
RP	0.0	15.0	15.0	20.4	13.3	21.2	15.0	
CP	0.0	8.3	7.0	9.1	3.8	5.5	11.4	
TP	0.0	1.0	1.0	1.4	0.9	1.4	1.0	6.7
TOTAL	8	206	242	253	395	439	149	1692
TP	0.5	12.2	14.3	15.0	23.3	26.0	8.8	

*RP stands for the percent N is of the row; CP, of the column; TP, of the total.

At the secondary level (Table LII), 31,706 pupils were classified for Title I assistance using the achievement test information. Of this number, 61% of the pupils were included on the basis of Iowa Tests of Educational Development results. The second most frequently used instrument at the secondary level was the Iowa Tests of Basic Skills. Thus, the two measures accounted for 89.5% of the 31,706 pupils classified as in need of Title I assistance.

When one contrasts the classification of boys (Table LIII) with that of girls (Table LIV) at the secondary level, the previously stated figures hold true for the total population. The Iowa Testing Programs supplied the bulk of the information for classification into projects at the secondary level. In terms of totals, there were 18,256 boys and 13,450 girls classified under achievement test information.

CONDENSED ACHIEVEMENT CODES BY GRADE
Total Boys and Girls (Secondary)

Code	Grade						Total
	7	8	9	10	11	12	
3	3626	3791	1284	162	73	70	9006
RP*	40.3	42.1	14.3	1.8	0.8	0.8	
CP	81.0	78.9	19.1	2.7	1.4	1.6	
TP	11.4	12.0	4.0	0.5	0.2	0.2	28.4
4	21	33	4755	5567	5016	3987	19379
RP	0.1	0.2	24.5	28.7	25.9	20.6	
CP	0.5	0.7	70.6	91.9	94.0	92.9	
TP	0.1	0.1	15.0	17.6	15.8	12.6	61.1
6	0	91	119	198	160	150	718
RP	0.0	12.7	16.6	27.6	22.3	20.9	
CP	0.0	1.9	1.8	3.3	3.0	3.5	
TP	0.0	0.3	0.4	0.6	0.5	0.5	2.3
8	666	583	447	51	20	17	1784
RP	37.3	32.7	25.1	2.9	1.1	1.0	
CP	14.9	12.1	6.6	0.8	0.4	0.4	
TP	2.1	1.8	1.4	0.2	0.1	0.1	5.6
OTHER	162	305	132	80	70	70	819
RP	19.8	37.2	16.1	9.8	8.5	8.5	
CP	3.6	6.4	2.0	1.3	1.3	1.6	
TP	0.5	1.0	0.4	0.3	0.2	0.2	2.6
TOTAL	4475	4803	6737	6058	5339	4294	31706
TP	14.1	15.1	21.2	19.1	16.8	13.5	

*RP stands for the percent N is of the row; CP, of the column; TP, of the total.

CONDENSED ACHIEVEMENT CODES BY GRADE
Total Boys (Secondary)

Code	Grade						Total
	7	8	9	10	11	12	
3	2129	2159	768	80	37	41	5214
RP*	40.8	41.4	14.7	1.5	0.7	0.8	
CP	80.8	78.8	19.7	2.3	1.2	1.6	
TP	11.7	11.8	4.2	0.4	0.2	0.2	28.6
4	13	21	2720	3160	2920	2331	11165
RP	0.1	0.2	24.4	28.3	26.2	20.9	
CP	0.5	0.8	70.0	92.4	94.9	93.7	
TP	0.1	0.1	14.9	17.3	16.0	12.8	61.2
6	0	44	58	105	88	76	371
RP	0.0	11.9	15.6	28.3	23.7	20.5	
CP	0.0	1.6	1.5	3.1	2.9	3.1	
TP	0.0	0.2	0.3	0.6	0.5	0.4	2.0
8	388	354	271	43	15	16	1087
RP	35.7	32.6	24.9	4.0	1.4	1.5	
CP	14.7	12.9	7.0	1.3	0.5	0.6	
TP	2.1	1.9	1.5	0.2	0.1	0.1	6.0
OTHER	104	163	76	33	18	25	419
RP	24.8	38.9	18.1	7.9	4.3	6.0	
CP	3.9	5.9	2.0	1.0	0.6	1.0	
TP	0.6	0.9	0.4	0.2	0.1	0.1	2.3
TOTAL	2634	2741	3893	3421	3078	2489	18256
TP	14.4	15.0	21.3	18.7	16.9	13.6	

*RP stands for the percent N is of the row; CP, of the column; TP, of the total.

CONDENSED ACHIEVEMENT CODES BY GRADE
Total Girls (Secondary)

Code	Grade						Total
	7	8	9	10	11	12	
3	1497	1632	516	82	36	29	3792
RP*	39.5	43.0	13.6	2.2	0.9	0.8	
CP	81.3	79.1	18.1	3.1	1.6	1.6	
TP	11.1	12.1	3.8	0.6	0.3	0.2	28.2
4	8	12	2035	2407	2096	1656	8214
RP	0.1	0.1	24.8	29.3	25.5	20.2	
CP	0.4	0.6	71.6	91.3	92.7	91.7	
TP	0.1	0.1	15.1	17.9	15.6	12.3	61.1
6	0	47	61	93	72	74	347
RP	0.0	13.5	17.6	26.8	20.7	21.3	
CP	0.0	2.3	2.1	3.5	3.2	4.1	
TP	0.0	0.3	0.5	0.7	0.5	0.6	2.6
8	278	229	176	8	5	1	697
RP	39.9	32.9	25.3	1.1	0.7	0.1	
CP	15.1	11.1	6.2	0.3	0.2	0.1	
TP	2.1	1.7	1.3	0.1	0.0	0.0	5.2
OTHER	58	142	56	47	52	45	400
RP	14.5	35.5	14.0	11.8	13.0	11.3	
CP	3.2	6.9	2.0	1.8	2.3	2.5	
TP	0.4	1.1	0.4	0.3	0.4	0.3	3.0
TOTAL	1841	2062	2844	2637	2261	1805	13450
TP	13.7	15.3	21.1	19.6	16.8	13.4	

*RP stands for the percent N is of the row; CP, of the column; TP, of the total.

When the boys who were actually involved in Title I projects at the secondary level (Table LV) were compared with boys classified as in need of Title I assistance but not in projects (Table LVI), it is revealed that 13,144 boys did in fact receive help while 4,208 did not. Again, by far the most frequently used instrument in achievement testing were the Iowa Tests of Educational Development. The tests accounted for 60.8% of the boys involved in projects and 62.1% of those identified but who, in fact, did not receive assistance.

While there was no clear-cut evidence of a particular grade showing a tendency toward the use of achievement test information, the figures show that the ninth and tenth grades were most frequently reported as the years providing achievement information as far as boys were concerned.

Girls, when divided into two smaller groups - those in projects (Table LVII) and those identified but not in projects (Table LVIII) - showed a quite different distribution. There were 9,242 girls who were identified and involved in Title I activities while 4,208 thus identified did not receive assistance.

When the figures for boys were compared with those for girls, it became readily apparent that of the roughly 17,000 boys identified by achievement data, 13,000 received help. In contrast, of the approximately 13,500 girls thus identified, approximately 9,000 did receive help. One could conclude from these figures that on the basis of need as measured by achievement data, a boy stood the best chance of receiving assistance.

CONDENSED ACHIEVEMENT CODES BY GRADE
Boys in Project (Secondary)

Code	Grade						Total
	7	8	9	10	11	12	
3	1593	1626	600	76	33	35	3963
RP*	40.2	41.0	15.1	1.9	0.8	0.9	
CP	82.8	79.6	20.7	3.1	1.5	2.1	
TP	12.1	12.4	4.6	0.6	0.3	0.3	30.2
4	9	15	1980	2263	2152	1569	7988
RP	0.1	1.8	24.8	28.3	26.9	19.6	
CP	0.5	0.7	68.4	93.8	96.4	95.8	
TP	0.1	0.1	15.1	17.2	16.4	11.9	60.8
6	0	10	11	12	22	3	58
RP	0.0	17.2	19.0	20.7	37.9	5.2	
CP	0.0	0.5	0.4	0.5	1.0	0.2	
TP	0.0	0.1	0.1	0.1	0.2	0.0	0.4
8	266	294	252	37	13	14	879
RP	30.3	33.8	28.7	4.2	1.5	1.6	
CP	13.8	14.5	8.7	1.5	0.6	0.9	
TP	2.0	2.3	1.9	0.3	0.1	0.1	6.7
OTHER	55	95	52	25	12	17	256
RP	21.5	37.1	20.3	9.8	4.7	6.6	
CP	2.9	4.7	1.8	1.0	0.5	1.0	
TP	0.4	0.7	0.4	0.2	0.1	0.1	1.9
TOTAL	1923	2043	2895	2413	2232	1638	13144
TP	14.6	15.5	22.0	18.4	17.0	12.5	

*RP stands for the percent N is of the row; CP, of the column; and TP, of the total.

CONDENSED ACHIEVEMENT CODES BY GRADE
Boys Not in Project (Secondary)

Code	Grade						Total
	7	8	9	10	11	12	
3	536	533	168	4	4	6	1251
RP*	42.8	42.6	13.4	0.3	0.3	0.5	
CP	75.4	76.4	16.8	0.4	0.5	0.7	
TP	10.5	10.4	3.3	0.1	0.1	0.1	24.5
4	4	6	740	897	768	762	3177
RP	0.1	0.2	23.3	28.2	24.2	24.0	
CP	0.6	0.9	74.1	89.0	90.8	89.5	
TP	0.1	0.1	14.5	17.5	15.0	14.9	62.1
6	0	34	47	93	66	73	313
RP	0.0	10.9	15.0	29.7	21.1	23.3	
CP	0.0	4.9	4.7	9.2	7.8	8.6	
TP	0.0	0.7	0.9	1.8	1.3	1.4	6.1
8	122	57	19	6	2	2	208
RP	58.7	27.4	9.1	2.9	1.0	1.0	
CP	17.2	8.2	1.9	0.6	0.2	0.2	
TP	2.4	1.1	0.4	0.1	0.0	0.0	4.1
OTHER	49	68	24	8	6	8	163
RP	30.1	41.7	14.7	4.9	3.7	4.9	
CP	6.9	9.7	2.4	0.8	0.7	0.9	
TP	1.0	1.3	0.5	0.2	0.1	0.2	3.2
TOTAL	574	625	804	842	691	672	4208
TP	13.6	14.9	19.1	20.0	16.4	16.0	

*RP stands for the percent N is of the row; CP, of the column; and TP, of the total.

CONDENSED ACHIEVEMENT CODES BY GRADE
Girls in Project (Secondary)

Code	Grade						Total
	7	8	9	10	11	12	
3	1068	1142	393	68	32	24	2727
RP*	39.2	41.9	14.4	2.5	1.8	0.9	
CP	84.3	79.5	19.3	3.8	2.0	2.1	
TP	11.6	12.4	4.3	0.7	0.3	0.3	29.5
4	6	10	1432	1693	1500	1097	5738
RP	0.1	0.2	25.0	29.5	26.1	19.1	
CP	0.5	0.7	70.2	94.3	95.5	96.8	
TP	0.1	0.1	15.5	18.3	16.2	11.9	62.1
6	0	7	18	7	14	0	46
RP	0.0	15.2	39.1	15.2	30.4	0.0	
CP	0.0	0.5	0.9	0.4	0.7	0.0	
TP	0.0	0.1	0.2	0.1	0.1	0.0	0.5
8	166	177	158	7	3	1	512
RP	32.4	34.6	30.9	1.4	0.6	0.2	
CP	13.1	12.3	7.7	0.4	0.2	0.1	
TP	1.8	1.9	1.7	0.1	0.0	0.0	5.5
OTHER	27	101	39	20	21	11	219
RP	12.3	46.1	17.8	9.1	9.6	5.0	
CP	2.1	7.0	1.9	1.1	1.3	1.0	
TP	0.3	1.1	0.4	0.2	0.2	0.1	2.4
TOTAL	1267	1437	2040	1795	1570	1133	9242
TP	13.7	15.5	22.1	19.4	17.0	12.3	

*RP stands for the percent N is of the row; CP, of the column; TP, of the total.

CONDENSED ACHIEVEMENT CODES BY GRADE
Girls Not in Project (Secondary)

Code	Grade						Total
	7	8	9	10	11	12	
3	429	490	123	14	4	5	1065
RP*	40.3	46.0	11.5	1.3	0.4	0.6	
CP	74.7	78.4	15.3	1.7	0.6	0.7	
TP	10.2	11.6	2.9	0.3	0.1	0.1	25.3
4	2	2	603	714	596	559	2476
RP	0.1	0.1	24.4	28.8	24.1	22.6	
CP	0.3	0.3	75.0	84.8	86.3	83.2	
TP	0.0	0.0	14.3	17.0	14.2	13.3	58.8
6	0	40	43	86	58	74	301
RP	0.0	13.3	14.3	28.6	19.3	24.6	
CP	0.0	6.4	5.3	10.2	8.4	11.0	
TP	0.0	1.0	1.0	2.0	1.4	1.8	7.2
8	112	52	18	1	2	0	185
RP	60.5	28.1	9.7	0.5	1.1	0.0	
CP	19.5	8.3	2.2	0.1	0.3	0.0	
TP	2.7	1.2	0.4	0.0	0.0	0.0	4.4
OTHER	31	41	17	27	31	34	181
RP	17.1	22.7	9.4	14.9	17.1	18.8	
CP	5.4	6.6	2.1	3.2	4.5	5.1	
TP	0.7	1.0	0.4	0.6	0.7	0.8	4.3
TOTAL	574	625	804	842	691	672	4208
TP	13.6	14.9	19.1	20.0	16.4	16.0	

*RP stands for the percent N is of the row; CP, of the column; TP, of the total.

Other Factors

School districts were asked to identify other apparent factors that seem to be contributing to the educational deprivation of a child by classifying the factors on the basis of a set of codes. The tables which follow show the distributions or incidence of response for each of the other factor codes. The original document allowed for a possibility of twelve specific factors contributing to the educational deprivation of the child under the more general term "other factors." The distribution of response by grade level within SMSA level to each of the twelve categories is presented in Appendix A.

The tables which follow show a condensation of these codes into the six most frequently used codes with those showing lesser incidence of classification grouped under a heading "other." The key to the tables in this section follows:

Code 1	Behavior problem
Code 2	Culturally deprived
Code 3	Disruptive home and family conditions
Code 7	Lack of basic necessities
Code 9	Motivational deficiency
Code 12	Other
	(Such things as dropout, excessive absences, inadequate curriculum, medical problems, nutritional deficiency, underachieving gifted)

Table LIX of other factor codes shows the total distribution of pupils for grades kindergarten through six. The most frequently reported other factor was that of cultural deprivation. This factor accounted for 30.9% of the responses. The next two most frequently cited reasons under other factors were disruptive home and family conditions, accounting for 16.7% of the responses, and motivational deficiency, accounting for 15.8%.

The category "other factors" was used most frequently at the fourth and fifth grade levels. At the sixth grade level, other factors were present in only 4.3% of the cases. In terms of numbers, this percentage represented 541 cases out of the 12,518 reported at the elementary grade level.

When boys were considered alone (Table LX), the distributions were quite similar to those of the total group. Again cultural deprivation accounted for 28.7% of the responses listed under other factors. Motivational deficiency was second in terms of frequency accounting for 17.3% of the cases, while disruptive home and family conditions accounted for 16.2% of the responses. Again, the fourth and fifth grade levels showed the highest incidence of other factors listed as a cause for educational deprivation. The sixth grade accounted for 4.4% of the use of this category. In terms of numbers, there were 349 of the 7,670 boys classified at the sixth grade level under this response.

CONDENSED OTHER FACTOR CODES BY GRADE
Total Boys and Girls (Elementary)

Code	Grade							Total
	K	1	2	3	4	5	6	
1	109	125	122	126	126	157	23	788
RP*	13.8	15.9	15.5	16.0	16.0	19.9	2.9	
CP	7.6	6.1	6.4	5.4	5.4	6.7	4.3	
TP	0.9	1.0	1.0	1.0	1.0	1.3	0.2	6.3
2	608	721	550	535	680	646	126	3866
RP	15.7	18.6	14.2	13.8	17.6	16.7	3.3	
CP	42.2	35.1	28.9	23.1	29.4	27.5	23.3	
TP	4.9	5.8	4.4	4.3	5.4	5.2	1.0	30.9
3	261	363	327	321	374	376	65	2087
RP	12.5	17.4	15.7	15.4	17.9	18.0	3.1	
CP	18.1	17.7	17.2	13.9	16.2	16.0	12.0	
TP	2.1	2.9	2.6	2.6	3.0	3.0	0.5	16.7
7	60	113	114	145	148	136	38	754
RP	8.0	15.0	15.1	19.2	19.6	18.0	5.0	
CP	4.2	5.5	6.0	6.3	6.4	5.8	7.0	
TP	0.5	0.9	0.9	1.2	1.2	1.1	0.3	6.0
9	130	267	286	306	404	457	133	1983
RP	6.6	13.5	14.4	15.4	20.4	23.0	6.7	
CP	9.0	13.0	15.0	13.2	17.5	19.4	24.6	
TP	1.0	2.1	2.3	2.4	3.2	3.7	1.1	15.8
12	168	281	286	262	314	316	91	1718
RP	9.8	16.4	16.6	15.3	18.3	18.4	5.3	
CP	11.7	13.7	15.0	11.3	13.6	13.4	16.8	
TP	1.3	2.2	2.3	2.1	2.5	2.5	0.7	13.7
OTHER	106	184	216	218	268	265	65	1322
RP	8.0	13.9	16.3	16.5	20.3	20.0	4.9	
CP	7.4	9.0	11.4	11.4	11.6	11.3	12.0	
TP	0.8	1.5	1.7	1.7	2.1	2.1	0.5	10.6
TOTAL	1442	2054	1901	1913	2314	2353	541	12518
TP	11.5	16.4	15.2	15.3	18.5	18.8	4.3	

*RP stands for the percent N is of the row; CP, of the column; TP, of the total.

CONDENSED OTHER FACTOR CODES BY GRADE
Total Boys (Elementary)

Code	Grade							Total
	K	1	2	3	4	5	6	
1	81	96	94	109	105	134	21	640
RP*	12.7	15.0	14.7	17.0	16.4	20.9	3.3	
CP	9.8	7.7	7.8	9.0	7.5	9.4	6.2	
TP	1.1	1.3	1.2	1.4	1.4	1.7	0.3	8.3
2	335	413	329	310	384	360	69	2200
RP	15.2	18.8	15.0	14.1	17.5	16.4	3.1	
CP	40.6	32.9	27.3	25.6	27.3	25.2	20.4	
TP	4.4	5.4	4.3	4.0	5.0	4.7	0.9	28.7
3	144	224	204	190	206	233	38	1239
RP	11.6	18.1	16.5	15.3	16.6	18.8	30.1	
CP	17.5	17.9	16.9	15.7	14.6	16.3	11.2	
TP	1.9	2.9	2.7	2.5	2.7	3.0	0.5	16.2
7	27	61	58	83	97	82	21	429
RP	6.3	14.2	13.5	19.3	22.6	19.1	4.9	
CP	3.3	4.9	4.8	6.7	6.9	5.7	6.2	
TP	0.4	0.8	0.8	1.1	1.3	1.1	0.3	5.6
9	75	189	189	216	279	291	89	1328
RP	5.6	14.2	14.2	16.3	21.0	21.9	6.7	
CP	9.1	15.1	15.7	17.9	19.8	20.3	26.3	
TP	1.0	2.5	2.5	2.8	3.6	3.8	1.2	17.3
12	109	158	194	173	176	185	61	1056
RP	10.3	15.0	18.4	16.4	16.7	17.5	5.8	
CP	13.2	12.6	16.1	14.3	12.5	12.9	18.0	
TP	1.4	2.1	2.5	2.3	2.3	2.4	0.8	13.8
OTHER	54	113	137	128	160	146	40	778
RP	6.9	14.5	17.6	16.5	20.6	18.8	5.1	
CP	6.5	9.0	11.4	10.6	11.4	10.2	11.8	
TP	0.7	1.5	1.8	1.7	2.1	1.9	0.5	10.1
TOTAL	825	1254	1205	1209	1407	1431	339	7670
TP	10.8	16.3	15.7	15.8	18.3	18.7	4.4	

RP stands for the percent N is of the row; CP, of the column; TP, of the total.

When the condensed other factor codes for girls (Table LXI) were examined, cultural deprivation accounted for 34.4% of the listings. Disruptive home and family conditions appeared as the second most frequent category, accounting for 17.5% of the cases. As with boys, the fourth and fifth grades appeared to be the grades where this category was used most frequently and the sixth grade showed the lowest incidence of this category. In all, there were a total of 4,848 responses for girls classified.

Boys actually in projects (Table LXII) were compared with the total number of boys identified as in need of assistance (Table LXIII) at the elementary level, revealing that 6,111 boys of 7,670 identified who were involved in projects listed other factors as contributing to project involvement. In contrast, 4,848 girls were listed under other factor codes as eligible for Title I assistance. Of this number, 3,756 were actually involved in Title I activities at the elementary level (Table LXIV), while 1,092 were not (Table LXV).

In general, having once been identified as in need of Title I assistance at the elementary level, the frequency of actually getting help was much higher in terms of proportion for boys than it was for girls.

CONDENSED OTHER FACTOR CODES BY GRADE
Total Girls (Elementary)

Code	Grade							Total
	K	1	2	3	4	5	6	
1	28	29	28	17	21	23	2	148
RP*	18.9	19.6	18.9	11.5	14.2	15.5	1.4	
CP	4.5	3.6	4.0	2.4	2.3	2.5	1.0	
TP	0.6	0.6	0.6	0.4	0.4	0.5	0.0	3.1
2	273	308	221	225	296	286	57	1666
RP	16.4	18.5	13.3	13.5	17.8	17.2	3.4	
CP	44.2	38.5	31.8	32.0	32.6	31.0	28.2	
TP	5.6	6.4	4.6	4.6	6.1	5.9	1.2	34.4
3	117	139	123	131	168	143	27	848
RP	13.8	16.4	14.5	15.4	19.8	16.9	3.2	
CP	19.0	17.4	17.7	18.6	18.5	15.5	13.4	
TP	2.4	2.9	2.5	2.7	3.5	2.9	0.6	17.5
7	33	52	56	62	51	54	17	325
RP	10.2	16.0	17.2	19.1	15.7	16.6	5.2	
CP	5.3	6.5	8.0	8.8	5.6	5.9	8.4	
TP	0.7	1.1	1.2	1.3	1.1	1.1	0.4	6.7
9	55	78	97	90	125	166	44	655
RP	8.4	11.9	14.8	13.7	19.1	25.3	6.7	
CP	8.9	9.8	13.9	13.6	13.8	18.0	21.8	
TP	1.1	1.6	2.0	1.9	2.6	3.4	0.9	13.5
12	59	123	92	89	138	131	30	662
RP	8.9	18.6	13.9	13.4	20.8	19.8	4.5	
CP	9.6	15.4	13.2	12.6	15.2	14.2	14.9	
TP	1.2	2.5	1.9	1.8	2.8	2.7	0.6	13.7
OTHER	52	71	79	90	108	119	25	544
RP	9.6	13.1	14.5	16.5	19.9	21.9	4.6	
CP	8.4	8.9	11.4	12.8	11.9	12.9	12.4	
TP	1.1	1.5	1.6	1.9	2.2	2.5	0.5	11.2
TOTAL	617	800	696	704	907	922	202	4848
TP	12.7	16.5	14.4	14.5	18.7	19.0	4.2	

*RP stands for the percent N is of the row; CP, of the column; TP, of the total.

CONDENSED OTHER FACTOR CODES BY GRADE
Boys in Project (Elementary)

Code	Grade							Total
	K	1	2	3	4	5	6	
1	43	64	67	71	73	102	18	438
RP*	9.8	14.6	15.3	16.2	16.7	23.3	4.1	
CP	8.5	6.3	6.9	7.1	6.3	8.6	6.5	
TP	0.7	1.0	1.1	1.2	1.2	1.7	0.3	7.1
2	194	345	271	260	326	308	62	1766
RP	11.0	19.5	15.3	14.7	18.5	17.4	3.5	
CP	38.3	34.1	27.7	26.0	28.2	26.0	22.5	
TP	3.2	5.6	4.4	4.3	5.3	5.0	1.0	28.9
3	96	190	161	151	169	204	29	1000
RP	9.6	19.0	16.1	15.1	16.9	20.4	2.9	
CP	19.0	18.8	16.5	15.1	14.6	17.2	10.5	
TP	1.6	3.1	2.6	2.5	2.8	3.3	0.5	16.4
7	15	48	52	73	86	71	12	357
RP	4.2	13.4	14.6	20.4	24.1	19.9	3.4	
CP	3.0	4.7	5.3	7.3	7.4	6.0	4.4	
TP	0.2	0.8	0.9	1.2	1.4	1.2	0.2	5.8
9	53	150	158	186	230	246	82	1105
RP	4.8	13.6	14.3	16.8	20.8	22.3	7.4	
CP	10.5	14.8	16.2	18.6	19.9	20.8	29.8	
TP	0.9	2.5	2.6	3.0	3.8	4.0	1.3	18.1
12	75	129	158	145	146	147	37	837
RP	9.0	15.4	18.9	17.3	17.4	17.6	4.4	
CP	14.8	12.8	16.2	14.5	12.6	12.4	13.5	
TP	1.2	2.1	2.6	2.4	2.4	2.4	0.6	13.7
OTHER	30	85	110	115	128	105	35	608
RP	4.9	14.0	18.1	18.9	21.1	17.3	5.8	
CP	5.9	8.4	11.3	11.5	11.1	8.9	12.7	
TP	0.5	1.4	1.8	1.9	2.1	1.7	0.6	9.9
TOTAL	506	1011	977	1001	1158	1183	275	6111
TP	8.3	16.5	16.0	16.4	18.9	19.4	4.5	

*RP stands for the percent N is of the row; CP, of the column; TP, of the total.

CONDENSED OTHER FACTOR CODES BY GRADE
Boys Not in Project (Elementary)

Code	Grade							Total
	K	1	2	3	4	5	6	
1	38	32	27	38	32	32	3	202
RP*	18.8	15.8	13.4	18.8	15.8	15.8	1.5	
CP	11.9	13.2	11.8	18.3	12.9	12.9	4.7	
TP	2.4	2.1	1.7	2.4	2.1	2.1	0.2	13.0
2	141	68	58	50	58	52	7	434
RP	32.5	15.7	13.4	11.5	13.4	12.0	1.6	
CP	44.2	28.0	25.4	24.0	23.3	21.0	10.9	
TP	9.0	4.4	3.7	3.2	3.7	3.3	0.4	27.8
3	48	34	43	39	37	29	9	239
RP	20.1	14.2	18.0	16.3	15.5	12.1	3.8	
CP	15.0	14.0	18.9	18.8	14.9	11.7	14.1	
TP	3.1	2.2	2.8	2.5	2.4	1.9	0.6	15.3
7	12	13	6	10	11	11	9	72
RP	16.7	18.1	8.3	13.9	15.3	15.3	12.5	
CP	3.8	5.3	2.6	4.8	4.4	4.4	14.1	
TP	0.8	0.8	0.4	0.6	0.7	0.7	0.6	4.6
9	22	39	31	30	49	45	7	223
RP	9.9	17.5	13.9	13.5	22.0	20.2	3.1	
CP	5.9	16.0	13.6	14.4	19.7	18.1	10.9	
TP	1.4	2.5	2.0	1.9	3.1	2.9	0.4	14.3
12	34	29	36	28	30	38	24	219
RP	15.5	13.2	16.4	12.8	13.7	17.4	11.0	
CP	10.7	11.9	15.8	13.5	12.0	15.3	37.5	
TP	2.2	1.9	2.3	1.8	1.9	2.4	1.5	14.0
OTHER	24	28	27	13	32	41	5	170
RP	14.1	16.5	15.9	7.6	18.8	24.1	2.9	
CP	7.5	11.5	11.8	6.3	12.9	16.5	7.8	
TP	1.5	1.8	1.7	0.8	2.1	2.6	0.3	10.9
TOTAL	319	243	228	208	249	248	64	1559
TP	20.5	15.6	14.6	13.3	16.0	15.9	4.1	

*RP stands for the percent N is of the row; CP, of the column; TP, of the total.

CONDENSED OTHER FACTOR CODES BY GRADE
Girls in Project (Elementary)

Code	Grade							Total
	K	1	2	3	4	5	6	
1	17	16	19	14	16	17	2	101
RP*	16.8	15.8	18.8	13.9	15.8	16.8	2.0	
CP	4.7	2.6	3.6	2.5	2.2	2.2	1.1	
TP	0.5	0.4	0.5	0.4	0.4	0.5	0.1	2.7
2	143	247	175	183	237	250	54	1289
RP	11.1	19.2	13.6	14.2	18.4	19.4	4.2	
CP	39.7	40.0	33.2	32.2	32.3	32.4	30.2	
TP	3.8	6.6	4.7	4.9	6.3	6.7	1.4	34.3
3	73	113	97	108	132	123	25	671
RP	10.9	16.8	14.5	16.1	19.7	18.3	3.7	
CP	20.3	18.3	18.4	19.0	18.0	15.9	14.0	
TP	1.9	3.0	2.6	2.9	3.5	3.3	0.7	17.9
7	18	37	39	55	47	43	13	252
RP	7.1	14.7	15.5	21.8	18.7	17.1	5.2	
CP	5.0	6.0	7.4	9.7	6.4	5.6	7.3	
TP	0.5	1.0	1.0	1.5	1.3	1.1	0.3	6.7
9	37	59	72	69	106	135	41	519
RP	7.1	11.4	13.9	13.3	20.4	26.0	7.9	
CP	10.3	9.6	13.7	12.1	14.5	17.5	22.9	
TP	1.0	1.6	1.9	1.8	2.8	3.6	1.1	13.8
12	43	101	68	67	110	105	22	516
RP	8.3	19.6	13.2	13.0	21.3	20.3	4.3	
CP	11.9	16.4	12.9	11.8	15.0	13.6	12.3	
TP	1.1	2.7	1.8	1.8	2.9	2.8	0.6	13.7
OTHER	29	44	56	72	85	99	22	408
RP	7.1	10.8	14.0	17.6	20.8	24.3	5.4	
CP	8.1	7.1	10.8	12.7	11.6	12.8	3.3	
TP	0.8	1.2	1.5	1.9	2.3	2.6	0.6	10.9
TOTAL	360	617	527	568	733	772	179	3756
TP	9.6	16.4	14.0	15.1	19.5	20.6	4.8	

*RP stands for the percent N is of the row; CP, of the column; TP, of the total.

CONDENSED OTHER FACTOR CODES BY GRADE
Girls Not in Project (Elementary)

Code	Grade							Total
	K	1	2	3	4	5	6	
1	11	13	9	3	5	6	0	47
RP*	23.4	27.7	19.1	6.4	10.6	12.8	0.0	
CP	4.3	7.1	5.3	2.2	2.9	4.0	0.0	
TP	1.0	1.2	0.8	0.3	0.5	0.5	0.0	4.3
2	130	61	46	42	59	36	3	377
RP	34.5	16.2	12.2	11.1	15.6	9.5	0.8	
CP	50.6	33.3	27.2	30.9	33.9	24.0	13.0	
TP	11.9	5.6	4.2	3.8	5.4	3.3	0.3	34.5
3	44	26	26	23	36	20	2	177
RP	24.9	14.7	14.7	13.0	20.3	11.3	1.1	
CP	17.1	14.2	15.4	16.9	20.7	13.3	8.7	
TP	4.0	2.4	2.4	2.1	3.3	1.8	0.2	16.2
7	15	15	17	7	4	11	4	73
RP	20.5	20.5	23.3	9.6	5.5	15.1	5.5	
CP	5.8	8.2	10.1	5.1	2.3	7.3	17.4	
TP	1.4	1.4	1.6	0.6	0.4	1.0	0.4	6.7
9	18	19	25	21	19	31	3	136
RP	13.2	14.0	18.4	15.4	14.0	22.8	2.2	
CP	7.0	10.4	14.8	15.4	10.9	20.7	13.0	
TP	1.6	1.7	2.3	1.9	1.7	2.8	0.3	12.5
12	16	22	24	22	28	26	8	146
RP	11.0	15.1	16.5	15.1	19.2	17.8	5.5	
CP	6.2	12.0	14.2	16.2	16.1	17.3	34.8	
TP	1.5	2.0	2.2	2.0	2.6	2.4	0.7	13.4
OTHER	23	27	22	18	23	20	3	136
RP	16.9	19.9	16.2	13.2	16.9	14.7	2.2	
CP	8.9	14.8	13.0	13.2	13.2	13.3	13.0	
TP	2.1	2.5	2.0	1.6	2.1	1.8	0.3	12.5
TOTAL	257	183	169	136	174	150	23	1092
TP	23.5	16.8	15.5	12.5	15.9	13.7	2.1	

*RP stands for the percent N is of the row; CP, of the column; TP, of the total.

Handicap Codes

A complete listing of the children classified under the six handicap codes appears in the appendix for this section. The following represents in summary form the more salient features of these tables. The discussion will be of the elementary and secondary levels.

At the elementary level, a total of 4,672 children were classified under handicap codes. Of the total, 2,989 were boys and 1,683 were girls. The most frequently listed handicap code for both boys and girls was "emotionally disturbed," 29.2% of the total elementary pupils being classified under this code. Boys were more frequently listed than girls as "emotionally disturbed" as 30.7% of the total boys were thus classified while the category accounted for only 26.6% of the total girls. In terms of relative frequency, the second and third ranked classifications were "speech handicap" and "hearing handicap." Together these two classifications accounted for 47.8% more of the pupils. The three cited classifications accounted for 77% of the total pupils listed.

At the secondary level, the most frequently listed handicap code was "mentally retarded." This classification accounted for 33.2% of the pupils. In terms of frequency, the "emotionally disturbed" classification accounted for an additional 28.9% of the pupils. In total, these two categories accounted for 62.1% of the 2,693 secondary pupils classified under handicap codes. When examined separately by sex there were 1,594 boys and 1,099 girls listed under handicap codes.

Other Factor Codes

Project applications included a separate classification of students when other apparent factors seemed to be contributing to the educational deprivation of the child. The instructions were for a listing of the single most significant factor to be recorded under the twelve possible classifications.

The classifications were:

1. Behavior Problem
2. Culturally Deprived
3. Disruptive Home and Family Conditions
4. Dropout
5. Excessive Absences
6. Inadequate Curriculum
7. Lack of Basic Necessities
8. Medical Problems
9. Motivational Deficiency
10. Nutritional Deficiency
11. Underachieving Gifted
12. Other

Table LXVI presents the condensation of Other Factor codes for boys and girls at the secondary level. In all 11,958 pupils were classified under Other Factors. The most frequently listed contributing factor was

CONDENSED OTHER FACTOR CODES BY GRADE
Total Boys and Girls (Secondary)

Code	Grade						Total
	7	8	9	10	11	12	
2	412	493	693	623	505	358	3084
RP*	13.4	16.0	22.5	20.2	16.4	12.5	
CP	25.9	27.9	28.2	25.5	24.6	21.7	
TP	3.4	4.1	5.8	5.2	4.2	3.0	25.8
3	250	256	348	285	270	160	1569
RP	15.9	16.3	22.2	18.2	17.2	10.2	
CP	15.7	14.5	14.2	11.7	13.1	9.7	
TP	2.1	2.1	2.9	2.4	2.3	1.3	13.1
6	101	123	211	280	261	196	1172
RP	8.6	10.5	18.0	23.9	22.3	16.7	
CP	6.4	7.0	8.6	11.5	12.7	11.9	
TP	0.8	1.0	1.8	2.3	2.2	1.6	9.8
7	117	106	187	158	168	148	884
RP	13.2	12.0	21.2	17.9	19.0	16.7	
CP	7.4	6.0	7.6	6.5	8.2	9.0	
TP	1.0	0.9	1.6	1.3	1.4	1.2	7.4
9	338	416	483	609	449	465	2760
RP	12.2	15.1	17.5	22.1	16.3	16.8	
CP	21.3	23.6	19.7	24.7	21.8	28.3	
TP	2.8	3.5	4.0	5.1	3.8	3.9	23.1
12	196	155	277	177	151	131	1087
RP	18.0	14.3	25.5	16.3	15.9	12.1	
CP	12.3	8.8	11.3	7.2	7.3	8.0	
TP	1.6	1.3	2.3	1.5	1.3	1.1	9.7
OTHER	175	217	256	313	253	188	1402
RP	12.5	15.5	18.3	22.3	18.0	13.4	
CP	11.0	12.3	10.4	12.8	12.3	11.4	
TP	1.5	1.8	2.1	2.6	2.1	1.6	11.7
TOTAL	1589	1766	2455	2445	2057	1646	11958
TP	13.3	14.8	20.5	20.4	17.2	13.8	

*RP stands for the percent N is of the row; CP, of the column; TP, of the total.

that of "behavior problems" which represented 25.8% of the total. This factor was closely followed by the classification "motivational deficiency" which accounted for an additional 23.1% of the pupils. The third most frequently listed contributing factor was that of a disrupted home or family condition which accounted for 13.1%. In all, these three factors accounted for 62% of the 11,598 pupils classified under the twelve possible Other Factor codes at the secondary level.

Table LXVII shows the distribution of Other Factor codes when the classification of boys was considered separately. Here again, the major contributors in relation to the total were: cultural deprivation (23.9%), motivational deficiency (25.4%), and disruptive home and family condition (12.4%). In addition, 10.4% of the boys classified at the secondary level were faced with an "inadequate curriculum." In all, a total of 7,029 boys were included in this summary table.

Table LXVIII--the distribution of Other Factor codes by grade level for secondary girls--again showed the pattern of cultural deprivation (28.4%), motivational deficiency (19.8%), and disruptive home and family conditions (14.2%) as the most significant contributing classification factors. The classifications of 4,929 secondary girls are shown on the table.

Table LXIX and Table LXX present the distributions of secondary boys on the basis of Other Factor codes when being in a project was tabulated separately from not being included in a project. The distributions

CONDENSED OTHER FACTOR CODES BY GRADE
Total Boys (Secondary)

Code	Grade						Total
	7	8	9	10	11	12	
2	224	269	397	334	266	192	1682
RP*	13.3	16.0	23.6	20.0	15.8	11.4	
CP	23.4	26.4	27.3	23.7	21.9	19.7	
TP	3.2	3.8	5.6	4.8	3.8	2.7	23.9
3	150	146	187	149	145	92	869
RP	17.3	16.8	21.5	17.1	16.7	10.6	
CP	15.7	14.3	12.9	10.6	11.9	9.5	
TP	2.1	2.1	2.7	2.1	2.1	1.3	12.4
6	60	64	149	162	170	128	733
RP	3.2	8.7	20.3	22.1	23.2	17.5	
CP	6.3	6.3	10.2	11.5	14.0	13.9	
TP	0.9	0.9	2.1	2.3	2.4	1.8	10.4
7	64	51	104	90	91	77	477
RP	13.4	10.7	21.8	18.9	19.1	16.1	
CP	6.7	5.0	7.2	6.4	7.5	7.9	
TP	0.9	0.7	1.5	1.3	1.3	1.1	6.8
9	224	260	315	389	302	294	1784
RP	12.6	14.6	17.7	21.8	16.9	16.5	
CP	23.4	25.5	21.7	27.5	24.9	30.2	
TP	3.2	3.7	4.5	5.5	4.3	4.2	25.4
12	102	75	141	97	82	67	564
RP	18.1	13.3	25.0	17.2	14.5	11.9	
CP	10.7	7.4	9.7	6.9	6.7	6.9	
TP	1.5	1.1	2.0	1.4	1.2	1.0	8.0
OTHER	132	154	161	191	159	123	920
RP	14.3	16.7	17.5	20.8	17.3	13.4	
CP	13.8	15.1	11.1	13.5	13.1	12.6	
TP	1.9	2.2	2.3	2.7	2.3	1.7	13.1
TOTAL	956	1019	1454	1412	1215	973	7029
TP	13.6	14.5	20.7	20.1	17.3	13.8	

*RP stands for the percent N is of the row; CP, of the column; TP, of the total.

TABLE LXVIII

134

CONDENSED OTHER FACTOR CODES BY GRADE
Total Girls (Secondary)

Code	Grade						Total
	7	8	9	10	11	12	
2	188	224	296	289	239	166	1402
RP*	13.4	16.0	21.1	20.6	17.0	11.8	
CP	29.7	30.0	29.6	28.0	28.4	24.7	
TP	3.8	4.5	6.0	5.9	4.8	3.4	28.4
3	100	110	161	136	125	68	700
RP	14.3	15.7	23.0	19.4	17.9	9.7	
CP	15.8	14.7	16.1	13.2	14.8	10.1	
TP	2.0	2.2	3.3	2.8	2.5	1.4	14.2
6	41	59	62	118	91	68	439
RP	9.3	13.4	14.1	26.9	20.7	15.5	
CP	6.5	7.9	6.2	11.4	10.8	10.1	
TP	0.8	1.2	1.3	2.4	1.8	1.4	8.9
7	53	55	83	68	77	71	407
RP	13.0	13.5	20.4	16.7	18.9	17.4	
CP	8.4	7.4	8.3	6.6	9.1	10.5	
TP	1.1	1.1	1.7	1.4	1.6	1.4	8.3
9	114	156	168	220	147	171	976
RP	11.7	16.0	17.2	22.5	15.1	17.5	
CP	18.0	20.9	16.8	21.3	17.5	25.4	
TP	2.3	3.2	3.4	4.5	3.0	3.5	19.8
12	94	80	136	80	69	64	523
RP	18.0	15.3	26.0	15.3	13.2	12.2	
CP	14.8	10.7	13.6	7.7	8.2	9.5	
TP	1.9	1.6	2.8	1.6	1.4	1.3	10.6
OTHER	43	63	95	122	94	65	482
RP	8.9	13.1	19.7	25.3	19.5	13.5	
CP	6.8	8.4	9.5	11.8	11.2	9.7	
TP	0.9	1.3	1.9	2.5	1.9	1.3	9.8
TOTAL	633	747	1001	1033	842	673	4929
TP	12.8	15.2	20.3	21.0	17.1	13.7	

*RP stands for the percent N is of the row; CP, of the column; TP, of the total.

CONDENSED OTHER FACTOR CODES BY GRADE
Boys in Project (Secondary)

Code	Grade						Total
	7	8	9	10	11	12	
2	171	220	328	254	211	144	1328
RP*	12.9	16.6	24.7	19.1	15.9	10.8	
CP	23.5	27.5	29.3	24.8	22.6	21.1	
TP	3.2	4.2	6.2	4.8	4.0	2.7	25.1
3	108	106	138	107	103	60	622
RP	17.4	17.0	22.2	17.2	16.6	9.6	
CP	14.8	13.2	12.3	10.4	11.0	8.8	
TP	2.0	2.0	2.6	2.0	1.9	1.1	11.8
6	47	59	102	110	135	90	543
RP	8.7	10.9	18.8	20.3	24.9	16.6	
CP	6.5	7.4	9.1	10.7	14.5	13.2	
TP	0.9	1.1	1.9	2.1	2.6	1.7	10.3
7	61	47	99	82	80	64	433
RP	14.1	10.9	22.9	18.9	18.5	14.8	
CP	8.4	5.9	8.8	8.0	8.6	9.4	
TP	1.2	0.9	1.9	1.5	1.5	1.2	8.2
9	162	179	206	271	228	197	1243
RP	13.0	14.4	16.6	21.8	18.3	15.8	
CP	22.3	22.4	18.4	26.4	24.4	28.8	
TP	3.1	3.4	3.9	5.1	4.3	3.7	23.5
12	83	64	114	71	55	42	429
RP	19.3	14.9	26.6	16.6	12.8	9.8	
CP	11.4	8.0	10.2	6.9	5.9	6.1	
TP	1.6	1.2	2.2	1.3	1.0	0.8	8.1
OTHER	96	125	134	130	121	86	692
RP	13.9	18.1	19.4	18.8	17.5	12.4	
CP	13.2	15.6	12.0	12.7	13.0	12.6	
TP	1.8	2.4	2.5	2.5	2.3	1.6	13.1
TOTAL	728	800	1121	1025	933	683	5290
TP	13.8	15.1	21.2	19.4	17.6	12.9	

*RP stands for the percent N is of the row; CP, of the column; TP, of the total.

CONDENSED OTHER FACTOR CODES BY GRADE
Boys Not in Project (Secondary)

Code	Grade						Total
	7	8	9	10	11	12	
2	53	49	69	80	55	48	354
RP*	15.0	13.8	19.5	22.6	15.5	13.6	
CP	23.2	22.4	20.7	20.7	19.5	16.6	
TP	3.0	2.8	4.0	4.6	3.2	2.8	20.4
3	42	40	49	42	42	32	247
RP	17.0	16.2	19.8	17.0	17.0	13.0	
CP	18.4	18.3	14.7	10.9	14.9	11.0	
TP	2.4	2.3	2.8	2.4	2.4	1.8	14.2
6	13	5	47	52	35	38	190
RP	6.8	2.6	24.7	27.4	18.4	20.0	
CP	5.7	2.3	14.1	13.4	12.4	13.1	
TP	0.7	0.3	2.7	3.0	2.0	2.2	10.9
7	3	4	5	8	11	13	44
RP	6.8	9.1	11.4	18.2	25.0	29.5	
CP	1.3	1.8	1.5	2.1	3.9	4.5	
TP	0.2	0.2	0.3	0.5	0.6	0.7	2.5
9	62	81	109	118	74	97	541
RP	11.5	15.0	20.1	21.8	13.7	17.9	
CP	27.2	37.0	32.7	30.5	26.2	33.4	
TP	3.6	4.7	6.3	6.8	4.3	5.6	31.1
12	19	11	27	26	27	25	135
RP	14.1	8.1	20.0	19.3	20.0	18.5	
CP	8.3	5.0	8.1	6.7	9.6	8.6	
TP	1.1	0.6	1.6	1.5	1.6	1.4	7.8
OTHER	36	29	27	61	38	37	228
RP	15.8	12.7	11.8	26.8	16.7	16.2	
CP	15.8	13.2	8.1	15.8	13.5	12.8	
TP	2.1	1.7	1.6	3.5	2.2	2.1	13.1
TOTAL	228	219	333	387	282	290	1739
TP	13.1	12.6	19.1	22.3	16.2	16.7	

*RP stands for the percent N is of the row; CP, of the column; TP, of the total.

of the boys showed 5, 290 included in projects and 1, 739 identified but not included in projects at the secondary level.

The most significant difference in the two distributions occurred under the classification "motivational deficiency" with 23.5% of the boys included in projects listed, while for those identified but not included in projects, 31.1% were classified as possessing a "motivational deficiency." In general, this increase in the classification motivational deficiency for the identified group was the most plausible explanation for the other differences in the frequency of occurrence or percentage of response under the other codes.

It would appear that cultural deprivation was a salient Other Factor code for eventually being included in a project as 25.1% of those included as contrasted to 20.4% of boys not included listed this characteristic.

Tables LXXI and LXXII show the distribution of Other Factor code classifications for girls in projects and girls identified but not included in projects.

In terms of the difference in percent of classification for girls in projects as contrasted to girls not in projects, code 7--"lack of basic necessities"--was listed for 10.3% of those in projects and for only 2.8% of those not included in projects. The classification motivational deficiency followed the same pattern for girls as it did for boys with 18.1% of those in projects showing this classification while 24.3% of

CONDENSED OTHER FACTOR CODES BY GRADE
Girls in Project (Secondary)

Code	Grade						Total
	7	8	9	10	11	12	
2	138	175	240	194	172	113	1032
RP*	13.4	17.0	23.3	18.8	16.7	10.9	
CP	29.6	31.3	31.2	26.4	28.2	25.1	
TP	3.8	4.9	6.7	5.4	4.8	3.1	28.7
3	72	74	125	103	80	40	494
RP	14.6	15.0	25.3	20.9	16.2	8.1	
CP	15.4	13.2	16.3	14.0	13.1	8.9	
TP	2.0	2.1	3.5	2.9	2.2	1.1	13.8
6	32	53	33	63	72	37	290
RP	11.0	18.3	11.4	21.7	24.8	12.8	
CP	6.9	9.5	4.3	8.6	11.8	8.2	
TP	0.9	1.5	0.9	1.8	2.0	1.0	8.1
7	47	49	83	62	69	60	370
RP	12.7	13.2	22.4	16.8	18.6	16.2	
CP	10.1	8.7	10.8	8.4	11.3	13.3	
TP	1.3	1.4	2.3	1.7	1.9	1.7	10.3
9	81	109	106	157	96	102	651
RP	12.4	16.7	16.3	24.1	14.7	15.7	
CP	17.3	19.5	13.8	21.4	15.7	22.7	
TP	2.3	3.0	3.0	4.4	2.7	2.8	18.1
12	68	55	102	68	52	52	397
RP	17.1	13.9	25.7	17.1	13.1	13.1	
CP	14.6	9.8	13.3	9.3	8.4	11.6	
TP	1.9	1.5	2.8	1.9	1.4	1.4	11.1
OTHER	29	45	80	88	69	46	357
RP	8.1	12.6	22.4	24.6	19.3	12.9	
CP	6.2	8.0	10.4	12.0	11.3	10.2	
TP	0.8	1.3	2.2	2.5	1.9	1.3	9.9
TOTAL	467	560	769	735	610	450	3591
TP	13.0	15.6	21.4	20.5	17.0	12.5	

*RP stands for the percent N is of the row; CP, of the column; TP, of the total.

CONDENSED OTHER FACTOR CODES BY GRADE
Girls Not in Project (Secondary)

Code	Grade						Total
	7	8	9	10	11	12	
2	50	49	56	95	67	53	370
RP*	13.5	13.2	15.1	25.7	18.1	14.3	
CP	30.1	26.2	24.1	31.9	28.9	23.8	
TP	3.7	3.7	4.2	7.1	5.0	4.0	27.7
3	28	36	36	33	45	28	206
RP	13.6	17.5	17.5	16.0	21.8	13.6	
CP	16.9	19.3	15.5	11.1	19.4	12.6	
TP	2.1	2.7	2.7	2.5	3.4	2.1	15.4
6	9	6	29	55	19	31	149
RP	6.0	4.0	19.5	36.9	12.8	20.8	
CP	5.4	3.2	12.5	18.5	8.2	13.9	
TP	0.7	0.4	2.2	4.1	1.4	2.3	11.1
7	6	6	0	6	8	11	37
RP	16.2	16.2	0.0	16.2	21.6	29.7	
CP	3.6	3.2	0.0	2.0	3.4	4.9	
TP	0.4	0.4	0.0	0.4	0.6	0.8	2.8
9	33	47	62	63	51	69	325
RP	10.2	14.5	19.1	19.4	15.7	21.2	
CP	19.9	25.1	26.7	21.1	22.0	30.9	
TP	2.5	3.5	4.6	4.7	3.8	5.2	24.3
12	26	25	34	12	17	12	126
RP	20.6	19.8	27.0	9.5	13.5	9.5	
CP	15.6	13.4	14.7	4.0	7.3	5.4	
TP	1.9	1.9	2.5	0.9	1.3	0.9	9.4
OTHER	14	18	15	34	25	19	125
RP	11.2	14.4	12.0	27.2	20.0	15.2	
CP	8.4	9.6	6.5	11.4	10.8	8.5	
TP	1.0	1.3	1.1	2.5	1.9	1.4	9.3
TOTAL	166	187	232	298	232	223	1338
TP	12.4	13.9	17.3	22.3	17.3	16.7	

*RP stands for the percent N is of the row; CP, of the column; TP, of the total.

those identified but not later included in projects were classified under this code.

In total there were 3,591 girls included in Title I projects and 1,338 girls identified but not included in projects. The largest number of girls included in Title I activities was 769 at the ninth grade level. On the other hand, girls identified but not included in projects appeared most frequently at the tenth grade level with 298 or 22.3% of the total girls shown at this grade level.

PART III

In this part of the report the information presented deals with what has been described as the Internal Quantitative Dimension. Data on administrators, teachers and other educational personnel employed in Title I projects and those holding similar employment in non-Title I sections of the educational program are presented and compared. Information relating to pupil characteristics, program characteristics and information that describes pupil performance on the Iowa Testing Programs is also included in this part of the interim report.

Administrator and Teacher Information

The data shown in Table I for administrators were gathered from the Iowa Professional School Employee Records and the number of administrators represented presents in every case the maximum number reporting for the figure.

Down the left hand column of the table, the categories age in years, years experience in this district, years experience-total, total semester hours of college work, and salary in dollars are shown. Moving across the table to the left, the number of administrators reporting, the average number in each response category and the standard deviation for each category are presented for both Title I administrators and a comparison group of other administrators in the State of Iowa (labeled non-Title I).

Upon examining the table, it becomes readily apparent that there is little difference in any of the five characteristics listed. If there was a tendency, it was for Title I administrators to be slightly younger, slightly less experienced, and to earn a slightly smaller salary than their counterparts not involved in the programs.

TABLE I

A COMPARISON OF TITLE I AND NON-TITLE I
ADMINISTRATOR CHARACTERISTICS

	Title I			Non-Title I		
	<u>N</u>	<u>Ave</u>	<u>S. D.</u>	<u>N</u>	<u>Ave</u>	<u>S. D.</u>
Age in years	474	41.01	10.95	4236	41.64	11.55
Yrs. experience this district	497	6.13	7.05	4408	7.27	8.34
Yrs. exp. total	497	13.71	10.56	4407	14.95	11.86
Total sem. hrs. college work	490	164.10	30.44	4399	165.34	31.74
Salary in dollars	449	7561.77	1899.15	4397	7966.43	2191.37

This table expels the oftheard myth that administrative salaries for Title I programs were inconsistent with existing salary structures within the state. In fact, Title I administrators earned a mean salary of \$7,561.77 while their counterparts across the state earned a mean salary of \$7,966.43. In other words, when either the mean or the standard deviation of salary figures were considered, the Title I group earned a smaller salary and the range in salary was more constricted than that of their counterparts across the state.

Teacher Characteristics

Table II presents a comparison of Title I teachers with teachers in the state who are not involved in Title I programs. The makeup of the table is very similar to Table I in that it also presents comparable figures for the five categories shown in Table I.

When comparing teachers, the Title I group was slightly older, comparable in years of experience within the district and in total years of experience, had slightly less college work and earned a smaller salary than did their counterparts across the state.

TABLE II

A COMPARISON OF TITLE I AND NON-TITLE I TEACHER CHARACTERISTICS

	Title I			Non-Title I		
	<u>N</u>	<u>Ave</u>	<u>S. D.</u>	<u>N</u>	<u>Ave</u>	<u>S. D.</u>
Age in years	2911	41.83	12.69	24737	40.80	12.89
Yrs. experience this district	2976	5.27	6.08	25573	5.65	7.15
Yrs. exp. total	2975	11.88	10.02	25570	11.62	10.90
Total sem. hrs. college work	2897	128.25	33.54	25541	134.46	36.14
Salary in dollars	2242	5614.76	1429.02	25501	5802.55	1363.14

The mean salary figure for Title I teachers was \$5,614.76 while for non-Title I teachers the mean salary figure was \$5,802.55. Here again

we find evidence to support the notion that both the administrators and teachers employed in Title I programs were from the same pool of personnel that existed prior to the inception of the Title I programs, and that the salary structure initiated by Title I activities was, if anything, slightly below that for the comparable teachers across the state.

Other Professional Personnel

Table III presents the comparative statistics for the two groups of Other Professional Personnel in the State of Iowa. The professional personnel comparisons were made on the same five factors similar for administrative and teaching positions.

TABLE III

A COMPARISON OF TITLE I AND NON-TITLE I OTHER PROFESSIONAL STAFF CHARACTERISTICS

	Title I			Non-Title I		
	<u>N</u>	<u>Ave</u>	<u>S. D.</u>	<u>N</u>	<u>Ave</u>	<u>S. D.</u>
Age in years	164	40.28	11.18	1786	40.79	11.78
Yrs. experience this district	167	4.74	6.33	1846	5.98	7.55
Yrs. exp. total	167	11.03	9.40	1843	11.33	10.43
Total sem. hrs. college work	166	165.63	42.87	1839	159.17	42.74
Salary in dollars	165	7768.65	8955.76	1838	6630.37	1895.39

In the comparisons for Other Professional Personnel the Title I group on the average earned higher salaries by over a thousand dollars than did their statewide counterparts. But, on the other hand, they had more college work than their counterparts. In terms of similarity, they were comparable in years of experience, had slightly less experience in the district they were working but were very comparable in terms of their age. The average professional worker in the Title I program was approximately forty years old, and had been employed in the district for a little under five years.

If one ranked the salary figures for administrators, specialized professional workers and teachers, the three tables discussed would support the idea that administrators earned the highest salaries, specialized professional workers were second, and teachers were last. This is in keeping with the general trend across the country for pay scales at various professional levels and was consistent with existing personnel practices outside of Title I activities within the state.

Professional Preparation

A comparison of the professional preparation of administrators, teachers and other professional staff for Title I and non-Title I programs is shown in Table IV. The categories down the lefthand column of the table are: life certificate, bachelor's degree, master's degree, specialist degree, and doctor's degree. Across the top of the table and to the right

figures for administrators, teachers and other professional staff are shown under two headings -- Title I and non-Title I.

TABLE IV

A COMPARISON OF TITLE I AND NON-TITLE I PROFESSIONAL PREPARATION OF ADMINISTRATORS, TEACHERS AND OTHER PROFESSIONAL STAFF

	Admin.		Teachers		Other Prof.	
	Title I	Non-T.	Title I	Non-T.	Title I	Non-T.
Life certificate	34	227	860	6307	13	186
Bachelor's degree	158	1772	1877	16250	59	824
Master's degree	299	2309	238	2965	90	806
Specialist's degree	5	58	0	27	1	17
Doctor's degree	0	33	1	10	3	9

At the administrative level, Title I represented approximately one in ten of the administrative figures shown. The figures show that at the higher educational levels, i. e., specialist and doctoral degree levels, Title I administrators were underrepresented while at the lower levels, those of life certificate (which represents a normal school or less than bachelor's degree) and a bachelor's degree certificate were overrepresented.

For teachers the rough ratio of one to nine cited for administrators again holds. At the teaching level, the higher levels of education (the specialist and doctorate degrees) were again underrepresented by Title I

staff members, while the life certificate and bachelor degree levels were overrepresented in terms of Title I involved teachers.

At the level of other professional staff, the ratio of Title I to non-Title I drops below the one to nine previously used as a rough guideline. Here we find that Title I use of other professional staff members was not in proportion to the existence of these other staff members within the state. The major level of professional preparation for Title I professional staff members was the master's degree with ninety out of the 166 members having a master's degree. In the non-Title I category under Other Professional Staff, a larger proportion of the staff members had their training at less than a master's degree level. This was in contrast to the figures shown for the Title I involved staff.

When the professional preparation levels of Title I versus non-Title I were compared across groups, the general tendency was for the Title I participants to be less well prepared at the administrative and teaching levels, and slightly better prepared at the other professional staff level.

Assignment Codes

A comparison was made of the eighteen assignment codes listed on the IPSEDS report for Title I and non-Title I administrators, teachers, and other professional staff members. The results of these comparisons are shown as Table V.

TABLE V

A COMPARISON OF ASSIGNMENT CODES FOR TITLE I
AND NON-TITLE I ADMINISTRATORS, TEACHERS
AND OTHER PROFESSIONAL STAFF

	Admin.		Teachers		Other Prof.	
	Title I	Non-T.	Title I	Non-T.	Title I	Non-T.
1. Self contained classrooms	5	32	1197	7848	0	0
2. Departmentalized	41	260	631	5667	0	0
3. Fine arts	4	105	20	967	0	0
4. Foreign lang.	4	77	20	701	0	0
5. Health	1	31	3	79	0	0
6. Homemaking	0	48	10	593	0	0
7. Industrial ed.	12	124	42	689	0	0
8. Science	23	281	68	1177	0	0
9. Social studies	47	541	68	1235	0	0
10. Special education	1	10	65	576	0	0
11. Math	31	253	83	1109	0	0
12. Physical education	17	393	30	769	0	0
13. Official junior high school	51		225		0	
14. Agriculture	0	21	4	244	0	0
15. Vocational or business education	15	173	44	848	0	0
16. Communications	30	256	157	1707	0	0
17. Driver education	4	93	7	180	0	0
18. Non-teaching assign.	491	4381	0	0	163	1831

The figures shown for administrators represent a larger number of assignments than the total number of administrative positions in existence. This was possible because the assignment codes represented a duplicated counting of assignments. In other words, an administrator who spent part of his time in two assignments is listed twice. The majority of Title I administrators who had duties outside of their administrative function were in the areas listed on Table V as communications, i. e., English, social studies, math, served in administrative capacities for departmentalized schools or were junior high school officials. In contrast, non-Title I administrators frequently served dual functions different from those already listed for Title I administrators. These duties fell in the areas of physical education, science, the fine arts, industrial education and vocational or business education.

Turning to teachers, as would be expected the majority of teachers in Title I programs were assigned to self-contained classrooms. The second largest number of teachers in Title I programs were in departmentalized situations while the other two frequently listed categories for assignments were as officials in the junior high school and the communications (English) areas.

For non-Title I teachers, the most frequent assignment was also in a self-contained classroom with a departmentalized assignment showing the second most frequency. English, followed by social studies, science

and math, were the three frequently cited assignments for non-Title I teachers that did not overlap with Title I involved teaching staff. One would expect that these areas would have their representation proportional to the non-Title I teachers for Title I teachers. But, they do not.

When other professional staff assignment codes were tabulated, all non-professional staff in Title I and non-Title I categories showed non-teaching assignments as their total allotment of time. This is an expected finding.

Previous Years Occupation

A comparison was made of the previous year's occupation of administrators, teachers and other professional staff members for both Title I and non-Title I participants. Table VI presents the figures on which the comparisons were made. Down the lefthand column are listed seven possible categories of previous occupations. Across and down the table administrators', teachers' and other professional staff members' responses are shown.

TABLE VI

A COMPARISON OF PREVIOUS YEARS OCCUPATION FOR TITLE I AND NON-TITLE I ADMINISTRATORS, TEACHERS AND OTHER PROFESSIONAL STAFF

	Admin.		Teachers		Other Prof.	
	Title I	Non-T.	Title I	Non-T.	Title I	Non-T.
Teach-same dist.	403	3673	2382	20049	129	1502
Teach-same county, diff. dist.	4	34	37	296	3	10
Teach-diff. county	43	343	138	1245	16	99
Teach-diff. state	9	116	43	665	2	45
Not teach, but a student	15	178	167	2209	15	128
Not teach, but other activities	18	47	77	534	2	41
Unemployed	0	11	89	534	0	18

From the figures, the tendency for administrators to be involved in the same district prior to their involvement in Title I activities is indicated as 403 of the 492 respondents listed employment in the same district as their previous year's occupational classification. The same tendency held for non-Title I administrators.

The non-Title I administrators' response was more than the expected under the categories of teaching in a different state and spending their time as a student during the previous year. Interestingly, eleven of the administrators of the non-Title I group were unemployed the previous year. The best explanation or most plausible explanation for this finding

is the interrupted career pattern of women administrators as well as teachers at the elementary level, i. e., they spend a portion of their time away from their career and in their home as fulltime homemakers.

The pattern of teacher responses was similar to that for administrators in that the preponderance of teachers reporting listed teaching in the same district as their previous year's occupation. Where differences did occur between the Title I and non-Title I groups, it was in the two areas of non-Title I teachers having a greater tendency to be teaching in a different state or being employed as a student the previous year, while Title I teachers showed a greater tendency to be not teaching or unemployed during the year previous to their entry into the Title I program.

Other professional staff members' responses also showed the already stated pattern of being involved in the same district prior to the assignment to Title I programs. But, here we find the trend toward being employed in other activities or unemployed reversed with the non-Title I professional staff members showing a larger proportional representation in these two categories.

The special Pupil Inventory prepared by the Iowa Educational Information Center was administered in spring, 1966, to the public secondary school population in Iowa. A total of 199,251 pupils in 617 schools answered the Inventory. Each of the thirty-seven questions was designed to gather pupil information that might conceivably contribute to a better understanding of some educational problem.

The thirty-seven questions were printed in an eight-page booklet and administered as part of the CardPac System of Educational Accounting. Responses were marked by pupils on an IBM-sized answer card. The card was then "read" by an optical scanner and the information transferred to magnetic tape for immediate computer use. Each school was sent a report which included a breakdown of responses by its own pupils, as well as statewide totals.

The Item Analysis to follow shows how the responses of pupils were distributed in comparison to a sample of nonTitle I pupils, giving the number and the percent of pupils in each population selecting each of the suggested answers to each question.

It is hoped that a study of these responses will prove useful in finding solutions to known problems or in identifying new ones. Perhaps, also, this analysis may stimulate some fresh thinking about possible general improvements in the educational program for Title I pupils.

The value of an analysis of this kind clearly depends upon the

nature and quality of the items in the Inventory administered. A great deal has yet to be learned about what questions most need to be asked, how they may best be phrased, and how the data collected may best be presented. Each time a report of this kind is prepared, much is learned about how to make the next more useful and more readily interpretable.

The Analysis

In the tables used in the Item Analysis, the results are printed in the same sequence as the items appeared in the Inventory. Below each item are reproduced the possible responses given in the Inventory. The pupils' answers are summarized to the right of each item.

For each group, two columns of figures appear. The "N" column shows the actual number of pupils who chose each of the possible responses to the question. The second column, labeled "PC," shows what percent of the pupils chose each response.

With numbers of pupils as large as those shown, it should be pointed out that each response distribution shown for the two groups was statistically significant beyond the .05 level when subjected to the Chi Square test of independence.

Interpretation of the Report

Opinions may vary as to the most meaningful grouping of the Inventory items for consideration of the results. This will depend, to a great extent, on what comparisons the researcher is interested

in making. In general, however, the contents of the Inventory touch upon four broad areas of information. They are: (1) biography and environment; (2) activities; (3) aspirations and expectations; (4) attitudes, perceptions, and personal relationships.

An outline of these areas and the questions pertinent to each follows. This particular grouping of the items is offered as a usable example. Other logical groupings of the items and the corresponding response data may occur to the users of this report.

Area 1 Biography and Environment

Includes such characteristics as marital status of parents, parents' occupational and educational level, pupil's health, work, study, driving habits, etc.

Item #	Information
1 - 2	Family background information
3 - 5	Parents' occupation
6 - 7	Parents' education
8 - 9	Pupil time spent in work
10	General health
11	Home study habits
33 - 34	Auto driving characteristics

Area 2 Pupil Activities

Item #	In-School Activities
12	Athletics
13	Speech, Dramatics
14	Music
15	Publications
16	Student government
17	Service clubs
18	Honor societies
19	Academic clubs
20	Hobbies
21	Social activities

Area 3 - Aspirations and Expectations

Includes education and occupational goals - in terms of both rosy dreams and more realistic probabilities. In considering the responses, it is well to remember that the aspirations of a pupil are colored in many instances by the relative "glamour" of the choices offered.

Item #	Goals
25	School academic marks
26 - 28	Educational goals
29	Occupational goals (girl)

Area 4 - Attitudes, Perceptions, and Personal Relationships

Includes the pupil's view of his own standing, his attitudes toward schoolmates, teachers, and schoolwork, and certain pupil-parent relationships affecting study habits.

Item #	Attitudes
22	Pupil relationships
23	Study
24	Teacher relationships
30	Parental attitudes
31 - 32	Best and least-liked subjects
Item #	Future Plans
35	Financing education
36 - 37	Type and location of school preferred

In Part IV of this report, responses to selected items from the Inventory are compared to other relevant information on tested pupil achievement and mark point averages for the two groups of pupils. Here we were concerned with describing the Title I pupil population.

A COMPARISON OF RESPONSES OF TITLE I VS A SAMPLE OF
OTHER PUPILS TO INVENTORY ITEMS

	TITLE I		NON-TITLE I	
	N	PC	N	PC
1. Marital Status of Parents				
Married and Living Together	24686	73	27767	81
Mother Not Living	364	1	320	1
Father Not Living	1179	3	995	3
Married But Not Living Together	378	1	269	1
Divorced	1594	5	1285	4
Neither Parent Living	80		44	
Can't Answer Question	455	1	332	1
No Response	5209	15	3103	9
TOTALS	33945		34115	
2. Heads of House In Which You Live				
Mother and Father	23410	69	26891	79
Mother Only	2117	6	1685	5
Father Only	533	2	391	1
Sometimes Mother Sometimes Father	588	2	332	1
Mother and Stepfather	950	3	826	2
Father and Stepmother	290	1	281	1
Grandparents, Aunt, Uncle or Cousins	395	1	243	1
Brother or Sister	93		70	
Foster Parents	146		87	
None of Above	190	1	188	1
No Response	5233	15	3121	9
TOTALS	33945		34115	

	TITLE I		NON-TITLE I	
	N	PC	N	PC
3. Father's Occupation				
Cannot Answer Question	2713	8	1547	5
Farm Worker, Laborer, Workman	11551	34	8981	26
Private Household Worker, Housewife	217	1	109	
Clerk, Salesman	611	2	766	2
Semi-Skilled, Protective Worker	3383	10	3158	9
Service Worker	838	2	1564	5
Skilled Worker	3549	10	3890	11
Technician	485	1	768	2
Manager	1006	3	2205	6
Official	241	1	461	1
Proprietor or Owner	3541	10	5746	17
Professional	517	2	1742	5
No Response	5293	16	3178	9
TOTALS	33945		34115	
4. Mother's Occupation				
Cannot Answer Question	3042	9	1916	6
Farm Worker, Laborer, Workman	822	2	492	1
Private Household Worker, Housewife	18390	54	20417	60
Clerk, Salesman	1875	6	2785	8
Semi-Skilled, Protective Worker	1218	4	1107	3
Service Worker	730	2	825	2
Skilled Worker	631	2	520	2
Technician	118		138	
Manager	158		220	1
Official	109		141	
Proprietor or Owner	528	2	456	1
Professional	886	3	1882	6
No Response	5438	16	3216	9
TOTALS	33945		34115	
5. Mother's Work At Present				
Does Not Work For Pay	14761	43	17442	51
Works 10 or less hr. per week for pay	1542	5	1381	4
Works 10-20 hr. per week for pay	1248	4	1325	4
Works 20-30 hr. per week for pay	1275	4	1459	4
Works 30-40 hr. per week for pay	2691	8	3259	10
Works 40 or more hr. per week for pay	3221	9	3517	10
Can't Answer Question	3825	11	2530	7
No Response	5382	16	3202	9
TOTALS	33945		34115	

	TITLE I		NON-TITLE I	
	N	PC	N	PC
6. Father's Education				
No Formal Schooling	135		53	
Some Elementary	1145	3	624	2
Completed Elementary	5528	16	4090	12
Some High School	6756	20	5366	16
Graduated From High School	8503	25	10485	31
Some Bus. Tech. or Trade School	803	2	1181	3
Graduated Bus. Tech. or Trade School	600	2	1141	3
Less than 2 yrs. College	895	3	1781	5
More than 2, Less than 4 yrs. College	666	2	1503	4
Bachelor's Degree	411	1	1746	5
Master's Degree	165		632	2
Doctor's Degree	123		461	1
Don't Know	2982	9	1897	6
No Responses	5233	15	3155	9
TOTALS	33945		34115	
7. Mother's Education				
No Formal Schooling	116		61	
Some Elementary	472	1	241	1
Completed Elementary	3127	9	2277	7
Some High School	6089	18	4414	13
Graduated From High School	12255	36	13544	40
Some Bus. Tech. or Trade School	587	2	945	3
Graduated Bus. Tech. or Trade School	663	2	1304	4
Less than 2 yrs. College	990	3	1797	5
More than 2, Less than 4 yrs. College	1518	4	3028	9
Bachelor's Degree	454	1	1656	5
Master's Degree	75		155	
Doctor's Degree	27		41	
Don't Know	2306	7	1514	4
No Responses	5266	16	3138	9
TOTALS	33945		34115	
8. Hours Per Week Work For Pay				
NONE	10049	30	11874	35
1-5	6980	21	8463	25
6-10	4350	13	4331	13
11-15	2389	7	2176	6
16-20	1856	5	1651	5
21 or more	2949	9	2387	7
No Responses	5372	16	3233	9
TOTALS	33945		34115	

	TITLE I		NON-TITLE I	
	N	PC	N	PC
9. Hours Per Week Work For No Pay				
NONE	7661	23	7798	23
1-5	8333	25	10054	29
6-10	4983	15	5409	16
11-15	2619	8	2768	8
16-20	1689	5	1678	5
21 or more	3255	10	3064	9
No Response	5405	16	3344	10
TOTALS	33945		34115	
10. Physical Health				
No Physical Handicaps	26284	77	29150	85
Loss or Restricted Use of Limb	327	1	275	1
Deafness In At Least One Ear	295	1	151	
Blindness In At Least One Eye	261	1	150	
Asthma, Diabetes or Other Perm. Ail.	1377	4	1180	3
No Response	5401	16	3209	9
TOTALS	33945		34115	
11. Hours Per Week Homework Outside School				
NONE	3689	11	3009	9
1-4	14966	44	14284	42
5-9	7440	22	9713	28
10-14	1971	6	3047	9
15 or more	532	2	903	3
No Response	5347	16	3159	9
TOTALS	33945		34115	
12. Participation In Athletics				
Very Active	3813	11	5842	17
Fairly Active	7388	22	8253	24
Participated Little	2959	9	3079	9
Didn't participate, had opportunity	8313	24	8387	25
Didn't have activity, or not eligible	2234	7	3023	9
Can't answer question	3872	11	2340	7
No Response	5366	16	3191	9
TOTALS	33945		34115	

TITLE I

NON-TITLE I

N PC

N PC

13. Participation In Speech and Dramatics

Very Active	854	3	1685	5
Fairly Active	2173	6	3710	11
Participated Little	2195	6	2561	8
Didn't participate, had opportunity	12934	38	13814	40
Didn't have activity, or not eligible	5493	16	6230	18
Can't Answer Question	4862	14	2900	9
No Response	5434	16	3215	9
TOTALS	33495		34115	

14. Participation In Music

Very Active	3420	10	6908	20
Fairly Active	4393	13	6339	19
Participated Little	1356	4	1169	3
Didn't participate, had opportunity	13857	41	12672	37
Didn't have activity, or not eligible	1448	4	1535	4
Can't Answer Question	4032	12	2276	7
No Response	5439	16	3216	9
TOTALS	33945		34115	

15. Participation In Publications

Very Active	644	2	1278	4
Fairly Active	1478	4	1977	6
Participated Little	1433	4	1522	4
Didn't participate, had opportunity	13062	38	14415	42
Didn't have activity, or not eligible	6355	19	8085	24
Can't Answer Question	5594	16	3640	11
No Response	5379	16	3198	9
TOTALS	33945		34115	

16. Participation in Student Government

Very Active	582	2	1556	5
Fairly Active	665	2	1426	4
Participated Little	893	3	1103	3
Didn't participate, had opportunity	13187	39	13745	40
Didn't have activity, or not eligible	6400	19	7986	23
Can't Answer Question	6741	20	5049	15
No Response	5477	16	3250	10
TOTALS	33945		34115	

	TITLE I		NON-TITLE I	
	N	PC	N	PC
17. Participation in Service Clubs				
Very Active	2507	7	3503	10
Fairly Active	4205	12	4582	13
Participated Little	1434	4	1536	5
Didn't participate, had opportunity	9103	27	9627	28
Didn't have activity, or not eligible	6764	20	8684	25
Can't Answer Question	4464	13	2917	9
No Responses	5468	16	3266	10
TOTALS	33945		34115	
18. Participation in Honor Societies				
Very Active	299	1	819	2
Fairly Active	465	1	953	3
Participated Little	697	2	632	2
Didn't participate, had opportunity	8799	26	7621	22
Didn't have activity, or not eligible	11067	33	15886	47
Can't Answer Question	7089	21	4899	14
No Responses	5529	16	3305	10
TOTALS	33945		34115	
19. Participation in Academic Clubs				
Very Active	675	2	1108	3
Fairly Active	1708	5	2216	6
Participated Little	1026	3	1163	3
Didn't participate, had opportunity	9660	28	9954	29
Didn't have activity, or not eligible	9846	29	13053	38
Can't Answer Question	5483	16	3360	10
No Responses	5547	16	3261	10
TOTALS	33945		34115	
20. Participation in Hobby Clubs or Activities				
Very Active	1222	4	1320	4
Fairly Active	2181	6	2074	6
Participated Little	1397	4	1210	4
Didn't participate, had opportunity	7731	23	7846	23
Didn't have activity, or not eligible	11157	33	15401	45
Can't Answer Question	4704	14	2983	9
No Responses	5553	16	3281	10
TOTALS	33945		34115	

	TITLE I		NON-TITLE I	
	N	PC	N	PC
21. Participation In Social Activities				
Very Active	4866	14	6727	20
Fairly Active	9739	28	11365	33
Participated Little	5031	15	5267	15
Didn't participate, had opportunity	5240	15	4454	13
Didn't have activity, or not eligible	1491	4	1561	5
Can't Answer Question	2494	7	1503	4
No Response	5444	16	3238	9
TOTALS	33945		34115	
22. Unpleasant Experiences With Other Students				
A great Many	1086	3	587	2
Quite a Few	2362	7	1496	4
Not Very Many	8337	25	7173	21
Very Few	12351	36	15584	46
None	4410	13	6026	18
No Response	5399	16	3249	10
TOTALS	33945		34115	
23. General Attitude To Studying				
I really like it	592	2	889	3
I like it most of the time	5541	16	8668	25
Can't say I like or dislike it	17349	51	17117	50
I dislike it most of the time	3704	11	3345	10
I dislike it very much	1421	4	926	3
No Response	5338	16	3170	9
TOTALS	33945		34115	
24. How Do Teachers View You				
As a top pupil	348	1	1849	5
A good pupil	2684	8	10313	30
An average pupil	18818	55	16419	48
A below average pupil	5566	16	1872	5
A very poor pupil	930	3	265	1
No Response	5599	16	3397	10
TOTALS	33945		34115	

	TITLE I		NON-TITLE I	
	N	PC	N	PC
25. If In School Next Year Will Probably				
Get very low grades	1791	5	472	1
Get below average grades	6165	18	2140	6
Get average grades	16663	49	14229	42
Get above average grades	3211	9	11712	34
Get quite high grades	341	1	2037	6
No Response	5774	17	3525	10
TOTALS	33945		34115	
26. Educational Aspirations				
Less than high school graduation	588	2	203	1
High school graduation	6484	19	2456	7
On the job training	3407	10	1934	6
Go to school in military service	3204	9	1740	5
Tech. Trade or bus. sch - 2 yrs. or less	4850	14	3590	11
Tech. trade or bus. sch - more 2 yrs.	1967	6	1951	6
Some college, not graduate	763	2	939	3
Complete junior college	2668	8	2711	8
Bachelor's degree	3297	10	9950	29
Beyond a bachelor's degree	1183	3	5371	16
No Response	5534	16	3270	10
TOTALS	33945		34115	
27. Educational Expectations				
Less than high school graduation	541	2	208	1
High school graduation	7663	23	3782	11
On the job training	3141	9	2052	6
Go to school in military service	2631	8	1769	5
Tech. trade, bus. sch - 2 yrs. or less	4800	14	4027	12
Tech. trade, bus. sch - more 2 yrs.	1928	6	1941	6
Some college, not graduate	987	3	1418	4
Complete Junior College	2689	8	2807	8
Bachelor's degree	3143	9	9813	29
Beyond a bachelor's degree	742	2	2937	9
No Response	5680	17	3361	10
TOTALS	33945		34115	

TITLE I

NON-TITLE I

N PC

N PC

28. Aspiration-Expectation Difference in Education

Answered both questions the same	15916	47	19035	56
Parents want me to continue	3375	10	1649	5
Financial difficulty	2244	7	3648	11
Family responsibilities	829	2	789	2
Rather get married or work	1556	5	1766	5
Don't want to advance over second que	1734	5	2029	6
Expect to go in armed forces	2373	7	1491	4
No Response	5918	17	3717	11
TOTALS	33945		34115	

29. Future Vocation--Girls

Lifetime career other than homemaker	1902	13	1700	10
Career, then both career & homemaker	3513	24	5670	33
Career for awhile, then homemaker	3275	23	5434	31
Both career and homemaker	1897	13	1794	10
Homemaker	1482	10	869	5
No Response	2469	17	1877	11
TOTALS	14538		17344	

30. Parental Attitude Toward Homework Assigned

Probably don't care one way or other	9488	28	11524	34
Feel teachers give too much	3793	11	3643	11
Feel teachers give about right amt.	12372	36	13530	40
Feel teachers give too little	2184	6	1798	5
No Response	6108	18	3620	11
TOTALS	33945		34115	

31. Best Liked Subjects

Mathematics	4061	12	5011	15
English	3230	10	4008	12
Social Studies	2422	7	3331	10
Sciences	2565	8	4372	13
Foreign Languages	408	1	824	2
Music	1659	5	2289	7
Industrial Arts	6347	19	4135	12
Art	2047	6	1889	6
Business Education	1469	4	1430	4
Physical Education	4211	12	3574	10
No Response	5476	16	3252	10
TOTALS	33945		34115	

	TITLE I		NON-TITLE I	
	N	PC	N	PC
32. Least Liked Subjects				
Mathematics	7160	21	7850	23
English	6035	18	5419	16
Social Studies	5534	16	5275	15
Sciences	4171	12	3881	11
Foreign Languages	2039	6	2774	8
Music	1315	4	1609	5
Industrial Arts	499	1	1079	3
Art	736	2	1392	4
Business Education	324	1	589	2
Physical Education	466	1	833	2
No Response	5616	17	3414	10
TOTALS	33945		34115	
33. Do You Have A Car of Your Own				
Yes	5309	16	4683	14
No	22874	67	26076	76
No Response	5762	17	3356	10
TOTALS	33945		34115	
34. Frequency of Driving Parents Car				
Never	14305	42	15067	44
Once a week or less	5151	15	5063	15
Twice a week	2382	7	2452	7
Three times a week	1985	6	2171	6
Four times a week	1038	3	1364	4
Five or more times a week	3481	10	4724	14
No Response	5603	17	3274	10
TOTALS	33945		34115	
35. Plans To Finance Education Beyond High School				
Parents, Scholarship, Grant, Sav., etc.	4678	14	6553	19
Work or borrow part of money	4998	15	10758	32
Work or borrow all of money	2929	9	2458	7
Don't know at this time	8685	26	7463	22
Don't plan to continue education	6600	19	3315	10
No Response	6055	18	3568	10
TOTALS	33945		34115	

	TITLE I		NON-TITLE I	
	N	PC	N	PC
36. Type of School Expect to Attend This Fall or Later				
College	859	3	2710	8
Junior college	1210	4	1111	3
Technical school	421	1	352	1
Trade school	1191	4	540	2
Registered nursing less than B. S.	183	1	254	1
Apprenticeship training program	132		61	
Business school	742	2	612	2
Health services	193	1	184	1
Military service school	611	2	347	1
Correspondence training	157		109	
Be in same school system	18695	55	21695	64
Be in diff. but similar school	1478	4	1293	4
Don't expect to attend any school	2189	6	1366	4
No Response	5884	17	3481	10
TOTALS	33945		34115	

37. Where Do You Expect To Go To School

Do not expect to go to school	7462	22	3841	11
Hometown or near so can live at home	2681	8	3241	10
Iowa but away from home	4674	14	8833	26
Outside Iowa but in midwestern state	1536	5	2237	7
In a northeastern state	334	1	382	1
In a southeastern state	187	1	193	1
In a northwestern state	265	1	337	1
In a southwestern state	381	1	623	2
Outside the United States	149		156	
I do not know yet	10143	30	10657	31
No Response	6133	18	3615	11
TOTALS	33945		34115	

Attendance

Comparisons were made between the attendance pattern of Title I pupils who were involved in projects, Title I eligible pupils who were not involved in projects and a sample of non-involved or identified pupils from Iowa public schools were made. Comparisons of pupils from grades 7 through 12 are included in this analysis. Pupil attendance patterns were also compared on the basis of SMSA level, sex, and grade level. The figures shown in the following tables and graphs represent pupil totals within each of the categories.

Table VII presents a comparison of the days absent for total secondary Title I involved and identified boys and girls by Standard Metropolitan Statistical Area for which figures were available. On the left of the table the days absent are shown from 1 through 20. Across the table to the right appear the Standard Metropolitan Statistical Areas 1 through 5. The figures within the table show the number and the percent of the total that number represents for each of the Standard Metropolitan Statistical Areas.

In SMSA level 1, the absenteeism pattern for 3,282 pupils is shown; SMSA level 2 contained the absenteeism pattern for 599 pupils; SMSA level 3 contained information on 960 pupils; SMSA level 4 had 12,986 pupil absenteeism patterns; SMSA level 5 contained the pattern for 14,198 pupils.

TABLE VII

Days Absent for Total Title I Involved and Identified Boys and Girls
by Standard Metropolitan Statistical Area

Days	SMSA #1		SMSA #2		SMSA #3		SMSA #4		SMSA #5	
	N	%	N	%	N	%	N	%	N	%
1	1206	36.7	142	23.7	270	28.1	3789	29.2	4649	32.7
2	192	5.9	41	6.8	62	6.5	956	7.4	1166	8.2
3	182	5.5	37	6.2	53	5.5	890	6.9	1095	7.7
4	162	4.9	27	4.5	62	6.5	847	6.5	949	6.7
5	172	5.2	22	3.7	33	3.4	661	5.1	799	5.6
6	137	4.2	25	4.2	49	5.1	643	5.0	699	4.9
7	132	4.0	23	3.8	37	3.9	543	4.2	546	3.8
8	99	3.0	23	3.8	36	3.7	501	3.9	534	3.8
9	95	2.9	25	4.2	34	3.5	443	3.4	449	3.2
10	91	2.8	34	5.7	32	3.3	519	4.0	478	3.4
11	86	2.6	14	2.3	17	1.8	360	2.8	364	2.6
12	79	2.4	11	1.8	17	1.8	283	2.2	276	1.9
13	62	1.9	17	2.8	24	2.5	250	1.9	239	1.7
14	64	2.0	16	2.7	20	2.1	205	1.6	213	1.5
15	57	1.7	12	2.0	15	1.6	201	1.5	170	1.2
16	40	1.2	6	1.0	16	1.7	193	1.5	165	1.2
17	46	1.4	8	1.3	11	1.1	155	1.2	138	1.0
18	40	1.2	5	0.8	20	2.1	163	1.3	115	0.8
19	33	1.0	11	1.8	11	1.1	131	1.0	105	0.7
20	30	0.9	11	1.8	6	0.6	148	1.1	162	1.1
Tot.	3282		599		960		12986		14198	

Proportion of Student Absences for Total Title I
Involved and Identified Boys and Girls in Grades 7-12
By Standard Metropolitan Statistical Area

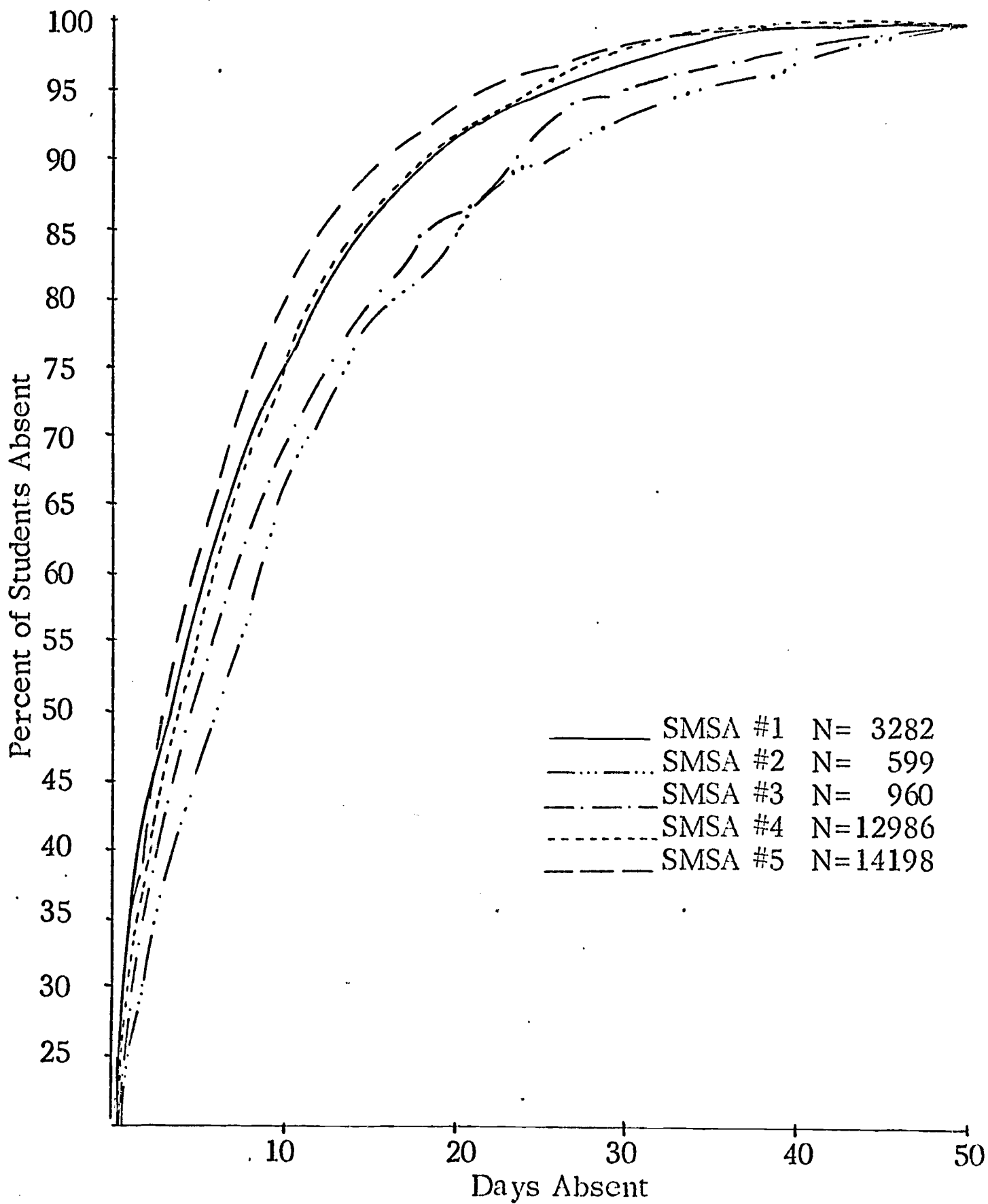

Figure 1.

In every case, the largest percentage of absence occurred under the one-day category. In other words, regardless of Standard Metropolitan Statistical Area, the largest number of pupils who were in fact absent were absent one day.

The graph that follows Table VII, identified as Figure 1, shows the cumulative frequency of absenteeism across Standard Metropolitan Statistical Areas. The graph shows pictorially the same figures as those shown on Table I, i. e., boys and girls combined in grades 7 through 12. A striking difference can be noted in the cumulative absence pattern for the districts shown. SMSA 1 can be thought of along with SMSA 4 as representative of the midpoint in the distribution. SMSA 5 showed the least absences in terms of cumulative frequency for pupils within this group. The pupils most frequently absent appeared in SMSA levels 2 and 3. The curves presented on this graph were subjected to the KOLMORGOROV-SMIRNOV statistic for comparing "goodness of fit" of curves and each of the differences was statistically significant beyond the .05 level across all SMSA levels.

In general, the cumulative frequency curve distribution shows that each of the Standard Metropolitan Statistical Areas had a unique attendance pattern for pupils who lived within that district.

Figure 2 shows the proportion of absences for all female students grades 7 through 12. The graph shows three curves - one for Title I involved girls, one for Title I identified but not involved girls, and a third for a sample of non-Title I girls who were in school at the same time. This third group was presented for comparison purposes. The figures which support the graph shown as Figure 2 are shown in a table following, titled Figure 2a.

Examining the three curves in Figure 2 again demonstrates that the non-Title I girls, or regular students, have the best attendance pattern, while the Title I involved and Title I identified girls had very similar attendance patterns; however, their patterns were in fact quite different from the non-involved Title I girls. The cumulative frequency graphs were constructed using a sample of approximately 30,000 students, and are, therefore, generalizable.

Next, the absence pattern for secondary girls was compared on the basis of Standard Metropolitan Statistical Area. There again we find that for girls the most frequent (in terms of percent) category of absence was the single-day pattern and there was a gradual reduction in percent of the total number of girls involved as the number of days of absence increased. These figures are shown as Table VIII.

Proportion of Student Absences for all Female Students
Grades Seven through Twelve

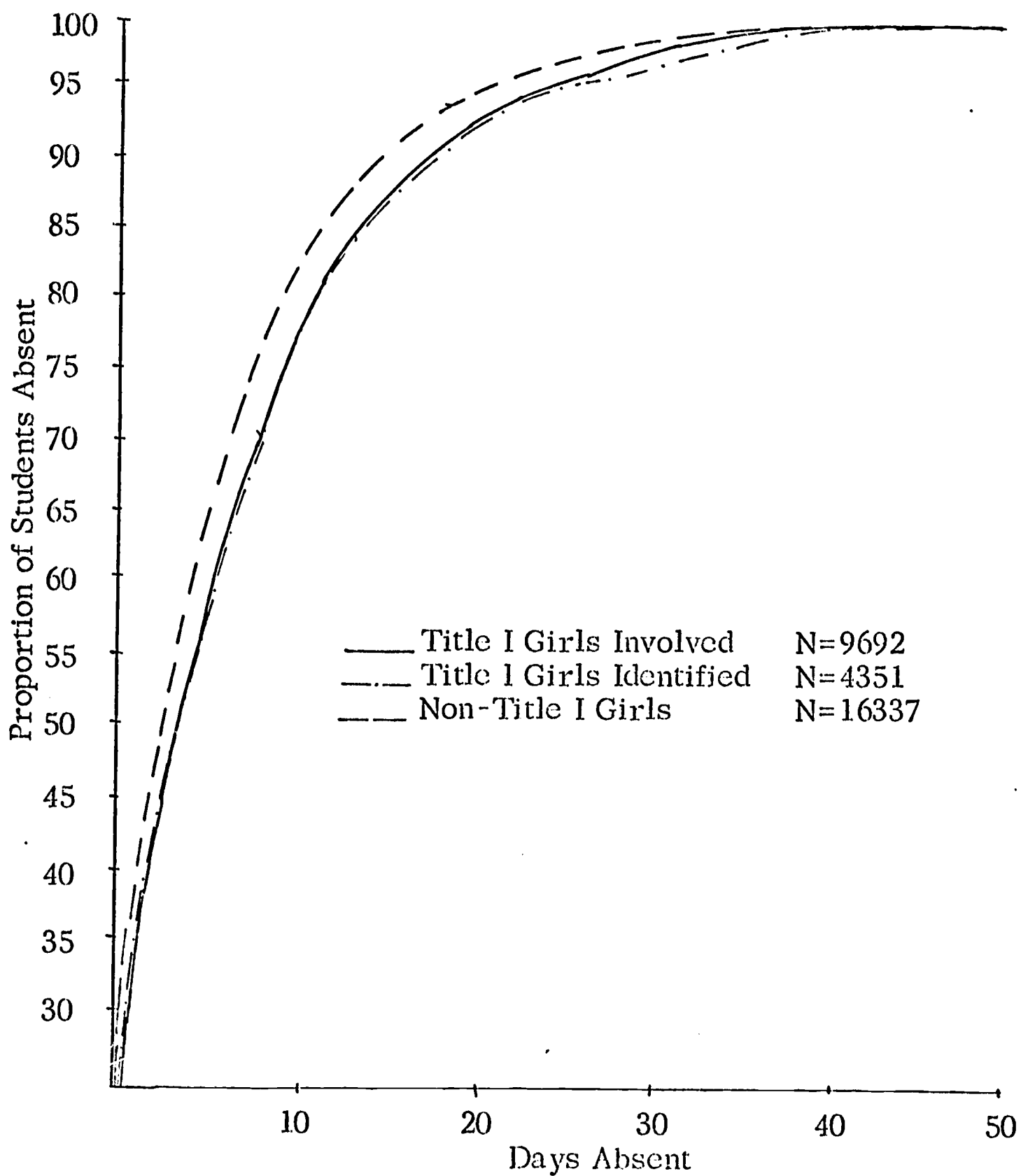

Figure 2.

Days Absent for Total Girls in Grades 7-12

* Days Absent	Title I Involved		Title I Identified		Non-Title I	
	N	Percent of Total	N	Percent of Total	N	Percent of Total
1	3036	31.3	1446	33.2	5911	36.2
2	738	7.6	306	7.0	1299	8.0
3	717	7.4	278	6.4	1206	7.4
4	624	6.4	251	5.8	1086	6.6
5	520	5.4	215	4.9	921	5.6
6	477	4.9	233	5.4	773	4.7
7	381	3.9	167	3.8	674	4.1
8	358	3.7	178	4.1	598	3.7
9	317	3.3	140	3.2	493	3.0
10	331	3.4	163	3.7	499	3.1
11	252	2.6	104	2.4	356	2.2
12	200	2.1	89	2.0	314	1.9
13	187	1.9	77	1.8	247	1.5
14	133	1.4	63	1.4	218	1.3
15	132	1.4	60	1.3	201	1.2
16	128	1.3	59	1.4	159	1.0
17	108	1.1	49	1.1	140	0.9
18	111	1.1	44	1.0	140	0.9
19	84	0.9	46	1.1	124	0.8
20	107	1.1	50	1.1	117	0.7
Total	9692		4351		16337	

*Statistical significance is identified at the .05 level according to the Kolmogorov-Smirnov Statistic when comparing Title I involved girls with Title I identified girls at $D = .024888$, Title I involved girls with Non-Title I girls at $D = .017416$, and Title I identified girls with Non-Title I girls at $D = .004466$.

Figure 2a.

Days Absent for Total Title I Involved and Identified Secondary Girls
by Standard Metropolitan Statistical Area

Days	SMSA #1		SMSA #2		SMSA #3		SMSA #4		SMSA #5	
	N	%	N	%	N	%	N	%	N	%
1	504	34.4	43	22.4	111	28.2	1575	28.9	1922	32.3
2	85	5.8	10	5.2	25	6.3	404	7.4	498	8.4
3	82	5.6	10	5.2	25	6.3	362	6.6	488	8.2
4	66	4.5	6	3.1	23	5.8	351	6.4	400	6.7
5	81	5.5	7	3.6	11	2.8	289	5.3	331	5.6
6	72	4.9	13	6.8	23	5.8	292	5.4	288	4.8
7	59	4.0	5	2.6	22	5.6	207	3.8	232	3.9
8	48	3.3	8	4.2	16	4.1	219	4.0	231	3.9
9	41	2.8	7	3.6	17	4.3	185	3.4	196	3.3
10	45	3.1	10	5.2	14	3.6	215	3.9	182	3.1
11	39	2.7	3	1.6	5	1.3	160	2.9	141	2.4
12	37	2.5	7	3.6	7	1.8	115	2.1	116	2.0
13	29	2.0	8	4.2	12	3.0	106	1.9	98	1.6
14	24	1.6	2	1.0	9	2.3	76	1.4	75	1.3
15	27	1.8	6	3.1	8	2.0	81	1.5	71	1.2
16	20	1.4	1	0.5	5	1.3	79	1.4	74	1.2
17	24	1.6	2	1.0	2	0.5	64	1.2	65	1.1
18	15	1.0	5	2.6	10	2.5	67	1.2	55	0.9
19	18	1.2	1	0.5	2	0.5	60	1.1	47	0.8
20	12	0.8	3	1.6	3	0.8	61	1.1	71	1.2
Tot.	1464		192		394		5757		5944	

When the attendance patterns were grouped by Standard Metropolitan Statistical Areas and graphed for secondary girl pupils, the cumulative frequency curves of Figure 3 resulted. Here again we find that SMSA level 5 shows the cumulative curve of least absence, while SMSA level 2 shows the cumulative curve of the most frequent absence pattern. These figures were based on available figures for 14,198 girls in SMSA 5 and 599 girls in SMSA level 2.

Proportion of Student Absences for Total Title I
Involved and Identified Secondary Girls
By Standard Metropolitan Statistical Area

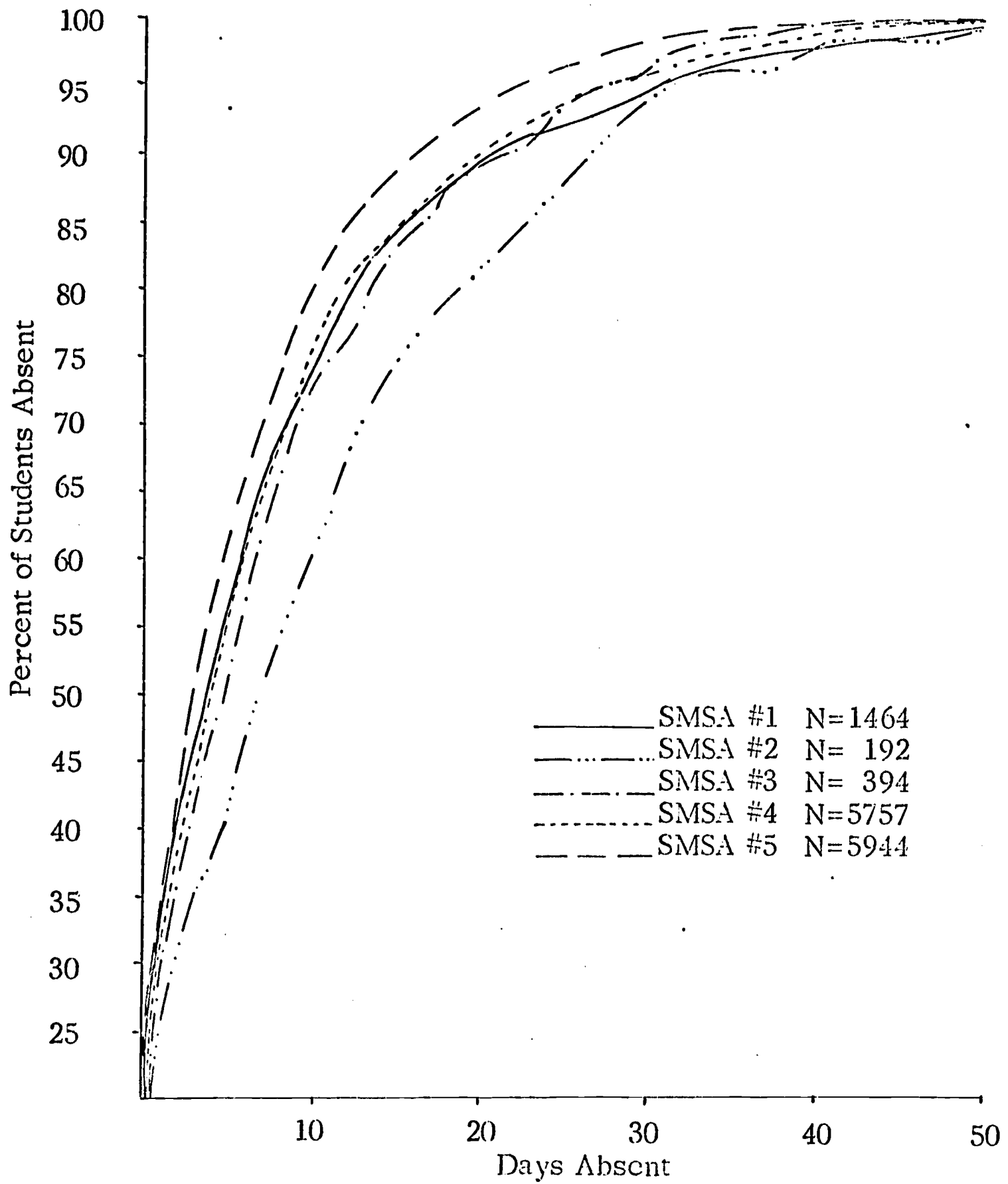

Figure 3.

Turning to the absenteeism figures for boys in grades 7 through 12 (Table IX), we find that information was available for a total of 13,897 secondary boys involved in Title I projects. While an additional 5,302 boys were identified as eligible for Title I support, they did not, in fact, become involved in projects. Also, a sample of 16,412 "regular students" is shown for comparison purposes.

As with the figures for girls, the largest percent of absences occurred in the category "one day" while the frequency of absences tended to get less in terms of the percent of the total as the number of days absent increased.

When shown as a cumulative frequency curve in Figure 4, it becomes apparent that for male students, Title I involved boys had the poorest record of attendance, closely followed by Title I identified but not involved and that the pattern for both groups was quite different from our sample of "regular" students. The best attendance pattern shown, as one would expect, was for those boys who were not involved or identified as Title I boys.

Days Absent for Total Boys in Grades 7-12

Days Absent *	Title I Involved		Title I Identified		Non-Title I	
	N	Percent of Total	N	Percent of Total	N	Percent of Total
1	4468	32.2	1809	34.1	6288	38.3
2	1048	7.5	382	7.2	1406	8.6
3	946	6.8	374	7.1	1174	7.2
4	886	6.4	349	6.6	1069	6.5
5	722	5.2	258	4.9	923	5.6
6	649	4.7	237	4.5	787	4.8
7	573	4.1	196	3.7	627	3.8
8	506	3.6	179	3.4	594	3.6
9	456	3.3	159	3.0	458	2.8
10	497	3.6	209	3.9	501	3.1
11	359	2.6	142	2.7	379	2.3
12	266	1.9	121	2.3	282	1.7
13	261	1.9	85	1.6	215	1.3
14	247	1.7	87	1.6	200	1.2
15	199	1.4	70	1.3	172	1.0
16	183	1.3	61	1.2	160	1.0
17	148	1.1	56	1.1	124	0.8
18	144	1.0	51	1.0	135	0.8
19	125	0.9	42	0.8	106	0.6
20	146	1.1	64	1.2	104	0.6
Total	13897		5302		16412	

*Statistical significance is identified at the .05 level according to the Kolmogorov-Smirnov Statistic when comparing Title I involved boys with Title I identified boys at $D = .019720$, Title I involved boys with Non-Title I boys at $D = .015640$, and Title I identified boys with Non-Title I boys at $D = .021488$.

Proportion of Student Absences for all Male Students
 Grades Seven Through Twelve

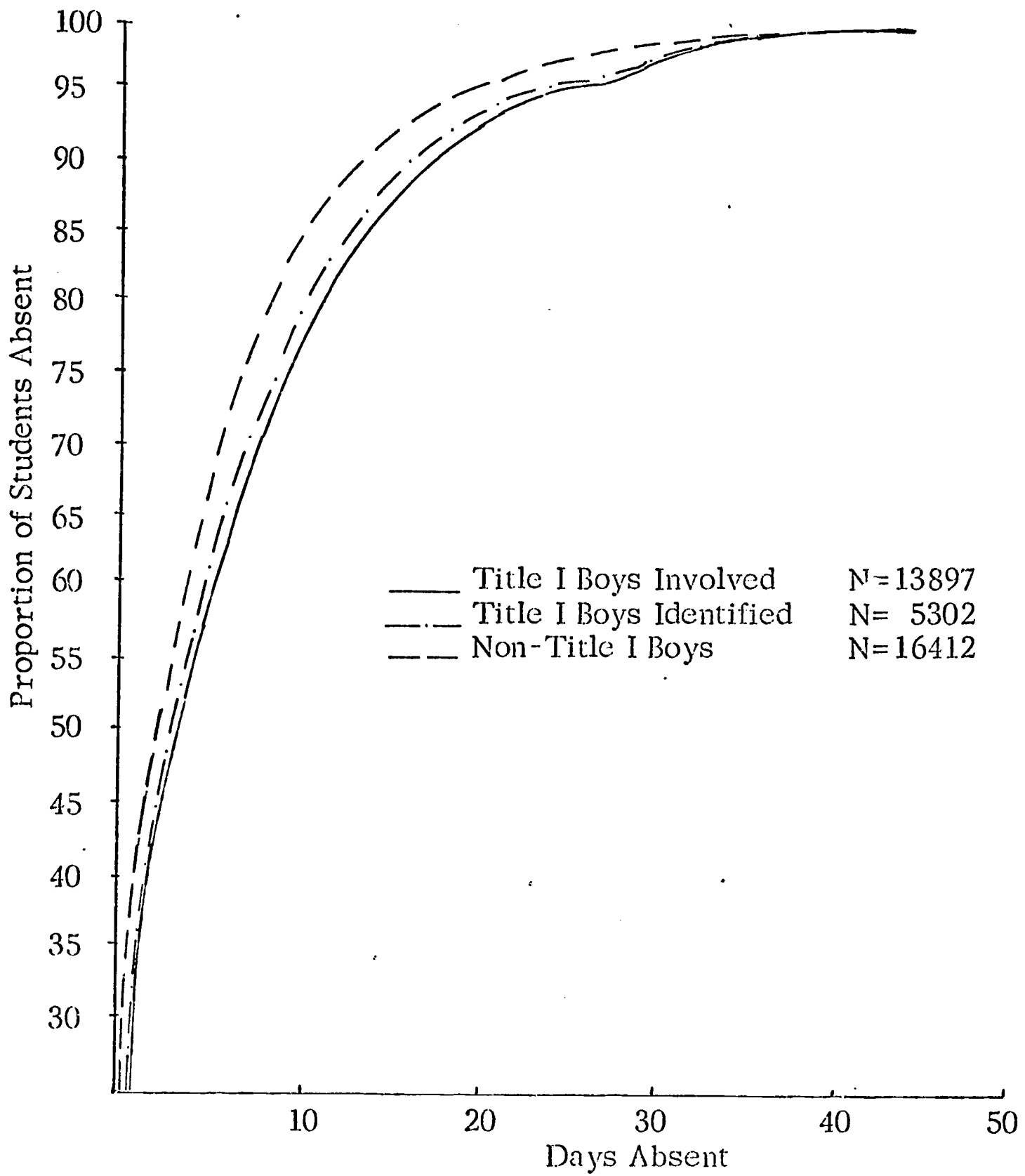

Figure 4.

Table X and Figure 5 present the information on attendance for secondary boys by SMSA level. SMSA level 3 showed the poorest attendance pattern in terms of a cumulative frequency curve. SMSA level 4 also showed a poor attendance curve pattern. But, only 407 cases were reported.

In each of the curves, the upper limits, those over thirty days, were shown by extrapolation.

TABLE X

182

Days Absent for Total Title I Involved and Identified Secondary Boys
by Standard Metropolitan Statistical Area

Days	SMSA #1		SMSA #2		SMSA #3		SMSA #4		SMSA #5	
	N	%	N	%	N	%	N	%	N	%
1	702	38.6	99	24.3	159	28.1	2214	29.4	2727	33.0
2	107	5.9	31	7.6	37	6.5	552	7.3	668	8.1
3	100	5.5	27	6.6	28	4.9	528	7.0	607	7.4
4	96	5.3	21	5.2	39	6.9	496	6.6	549	6.7
5	91	5.0	15	3.7	22	3.9	372	4.9	468	5.7
6	65	3.6	12	2.9	26	4.6	351	4.7	411	5.0
7	73	4.0	18	4.4	15	2.7	336	4.5	314	3.8
8	51	2.8	15	3.7	20	3.5	282	3.7	303	3.7
9	54	3.0	18	4.4	17	3.0	258	3.4	253	3.1
10	46	2.5	24	5.9	18	3.2	304	4.0	296	3.6
11	47	2.6	11	2.7	12	2.1	200	2.7	223	2.7
12	42	2.3	4	1.0	10	1.8	168	2.2	160	1.9
13	33	1.8	9	2.2	12	2.1	144	1.9	141	1.7
14	40	2.2	14	3.4	11	1.9	129	1.7	138	1.7
15	30	1.7	6	1.5	7	1.2	120	1.6	99	1.2
16	20	1.1	5	1.2	11	1.9	114	1.5	91	1.1
17	22	1.2	6	1.5	9	1.6	91	1.2	73	0.9
18	25	1.4	0	0.0	10	1.8	96	1.3	60	0.7
19	15	0.8	10	2.5	9	1.6	71	0.9	58	0.7
20	18	1.0	8	2.0	3	0.5	87	1.2	91	1.1
Tot.	1818		407		566		7529		8254	

Proportion of Student Absences for Total Title I
Involved and Identified Secondary Boys
By Standard Metropolitan Statistical Area

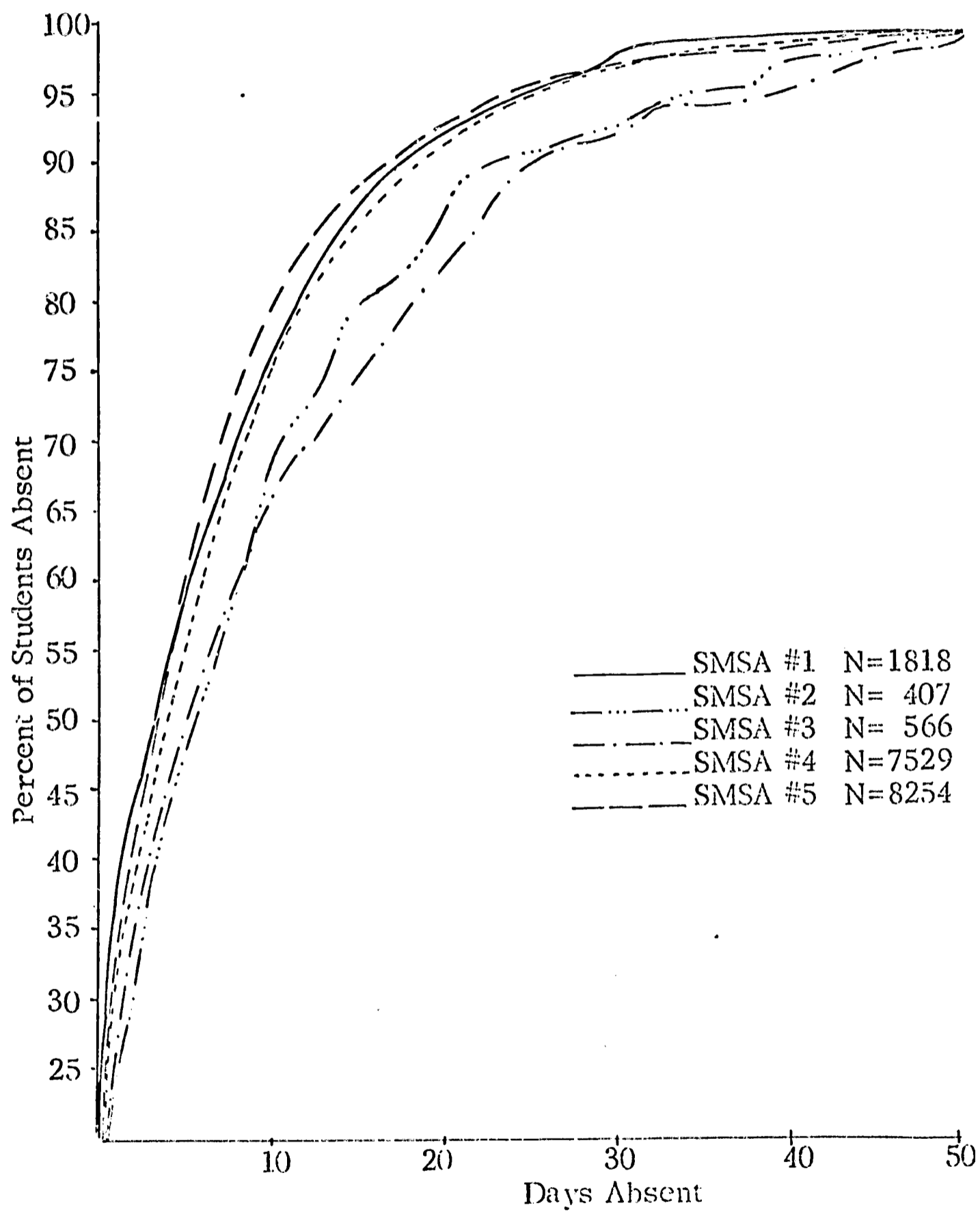

Figure 5.

THE IOWA TESTS OF EDUCATIONAL DEVELOPMENT

The Iowa Tests of Educational Development (ITED) were developed with two major purposes in mind. First, the authors of the tests state that "... teachers and counselors should keep themselves more intimately and reliably acquainted with the educational developments of each high school pupil." Second, the tests provide the school administrator with a more dependable and objective basis for evaluating the total educational offering of the school.

With these two major purposes in mind, a battery of nine objective tests was developed. The idea was to provide a comprehensive and dependable description of educational development. The tests themselves cover grades nine through twelve.

In the State of Iowa the ITED is used as an extension of or a supplement to the existing Iowa Testing Program for the elementary level. The individual test and the battery, the number of items, and the time necessary for completing the subtests of the battery are:

Title of Test	Items	Time
1. Understanding of Basic Social Concepts	90	55
2. Background in the Natural Sciences	90	60
3. Correctness and Appropriateness of Expression	99	60
4. Ability to Do Quantitative Thinking	53	65
5. Ability to Interpret Reading Materials in the Social Studies	80	60
6. Ability to Interpret Reading Materials in the Natural Sciences	80	60
7. Ability to Interpret Literary Materials	80	55
8. General Vocabulary	75	22
9. Use of Sources of Information	60	27

In Appendix B a complete reporting of the results by grade level within SMSA level for both boys and girls on the ITED may be found. In the body of the report the composite score by SMSA level is reported for boys and girls individually within two groups - Title I and non-Title I pupils. The composite score was chosen in the body of the text for consistency and also because it gives an indication of the general level of the pupil's educational development.

It should be noted that the composite test score is not a simple averaging of the standard scores on the test. It is obtained by changing the standard scores of the individual subtests into a weighted standard score. The composite score developed in this way has exactly the same meaning in terms of relative development as a standard score on any of the subtests. A complete description of the strengths of the ITED can be found in the manual prepared and furnished by The University of Iowa.

Composite Score by SMSA Level

Table XI shows the distribution of composite scores for Standard Metropolitan Statistical Area 1. The table shows the results for boys and girls within two major classifications. These are Title I-involved pupils and a general reference group that is labeled on the table Non-Title I pupils. Along the left-hand column, the range of percentile scores for the table is shown.

At the ninth grade level, the number of boys and girls included in

TABLE XI
 ITED - COMPOSITE SCORES FOR STANDARD METROPOLITAN
 STATISTICAL AREA 1

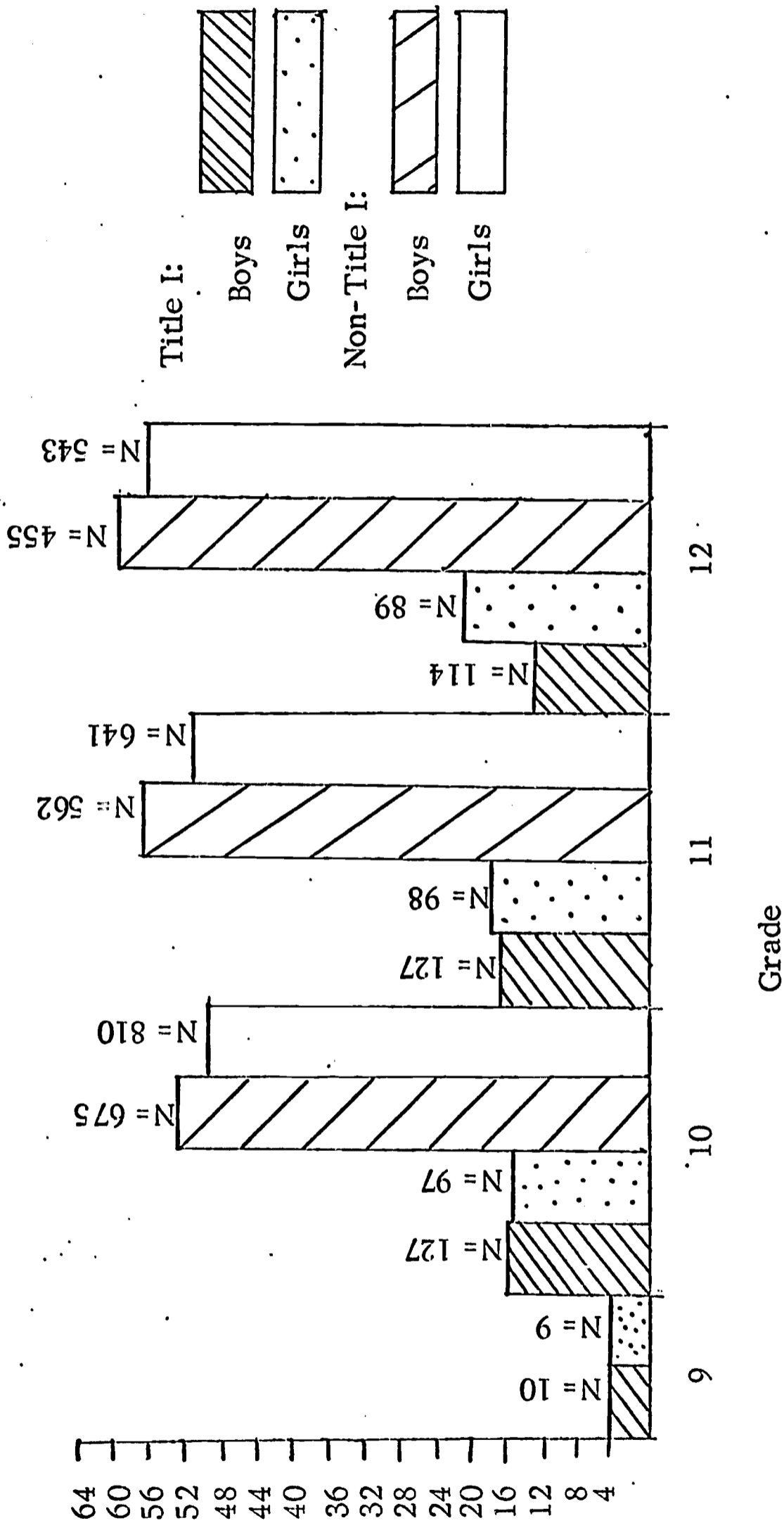

Title I programs who had ITED information available was nineteen. The reference group is not included at this grade level because the small number of pupils make comparisons tenuous.

At the tenth grade level, the discrepancy between the performance of Title I pupils and the norm group becomes readily apparent. For the Title I pupils, performance was close to the sixteenth percentile, while for the reference group it averaged close to the fiftieth percentile which represents normal progress for the grade level. At the eleventh and twelfth grade levels, the relative progress of the Title I group as contrasted to the representative sample, indicated the constant gap that existed between the two groups in SMSA level 1.

It is also interesting that for the comparison group the performance of boys exceeded the performance of girls at each of the three grade levels. The expected findings from the manual would be for girls to exceed boys in performance on the measure.

Table XII, which compared the composite scores on the ITED for Title I versus Non-Title I boys and girls in SMSA level 2, showed the problems encountered when test information was available for a relatively small sample of Title I pupils. At SMSA level 2, a meaningful number of Title I pupils was encountered at the ninth grade level. The table shows the discrepancy between the performance of Title I pupils and the sample selected for comparison at this grade level. SMSA levels 1 and 2, as would be expected from Part I of the report, did not contain the major

TABLE XII
 ITED - COMPOSITE SCORES FOR STANDARD METROPOLITAN
 STATISTICAL AREA 2

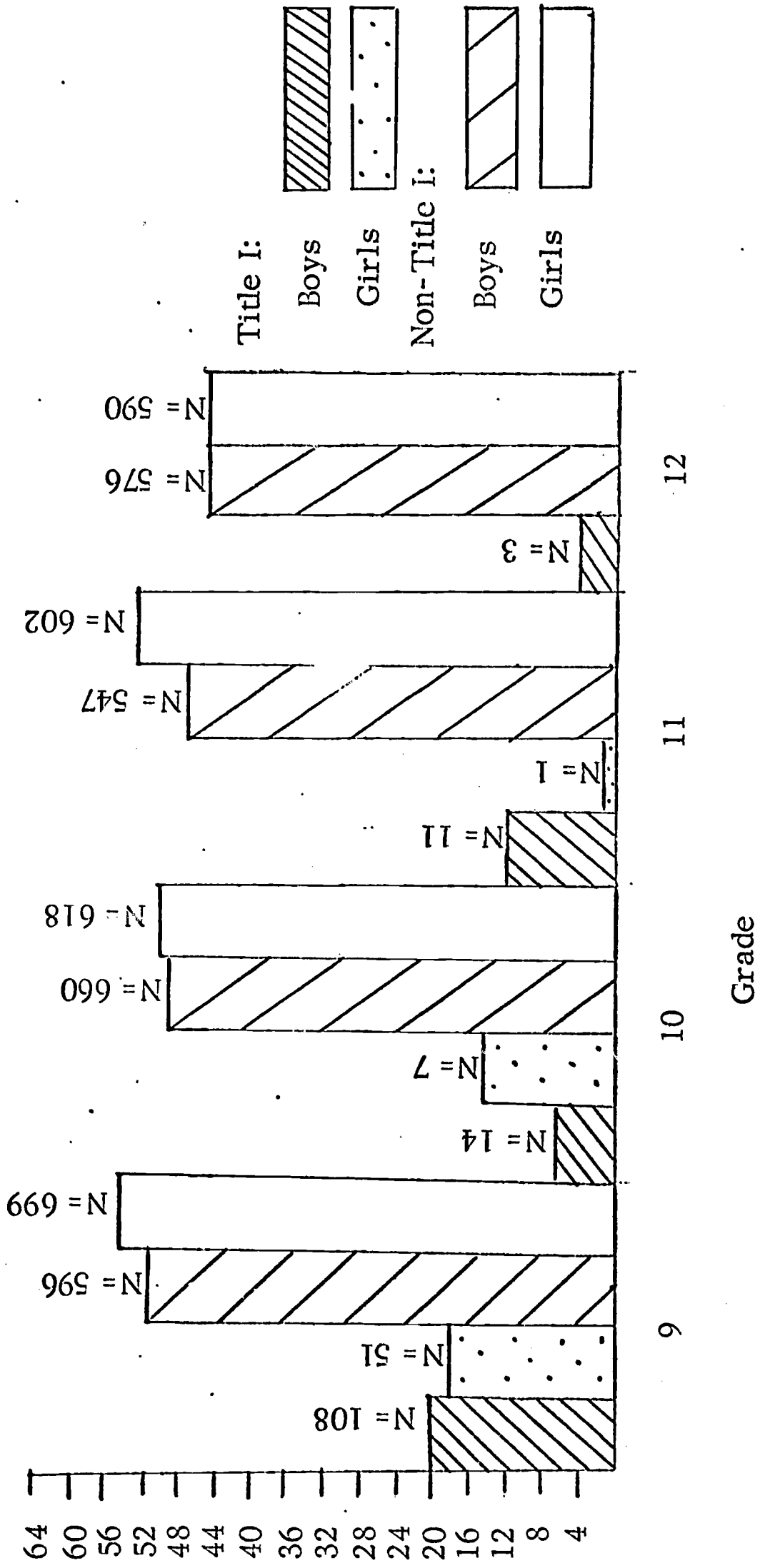

portion of Title I-involved pupils in the State of Iowa and their representation on a comparison by SMSA level reflects this lack of involvement.

Table XIII, the comparison for ITED composite scores for SMSA level 3, shows the discrepancy between performance on the measures for Title I boys and girls and the comparison group. The most striking feature of this table was the consistent low level of performance for Title I pupils across the four grade levels shown. In fact, at the twelfth grade level the performance of Title I boys and girls was lower than that at either the ninth, tenth or eleventh grade level. In comparison, the performance of the reference group was relatively stable across the four grade levels shown.

Tables XIV and XV, which show the composite score comparison for the two groups for SMSA level 4 and SMSA level 5, will be discussed simultaneously as they tended to reflect the pattern already noted for the other three SMSA levels.

SMSA levels 4 and 5 are the most meaningful tables in terms of sheer number of Title I pupils represented by composite score results. SMSA level 4, when performance across grade levels was examined, tended to again illustrate the relatively flat representation of Title I pupils in terms of their composite scores across grade levels. The discrepancy between the Title I performance and the performance of pupils in the comparison group was relatively constant and represented a span of approximately forty to fifty percentile points.

TABLE XIII
 ITED - COMPOSITE SCORES FOR STANDARD METROPOLITAN
 STATISTICAL AREA 3

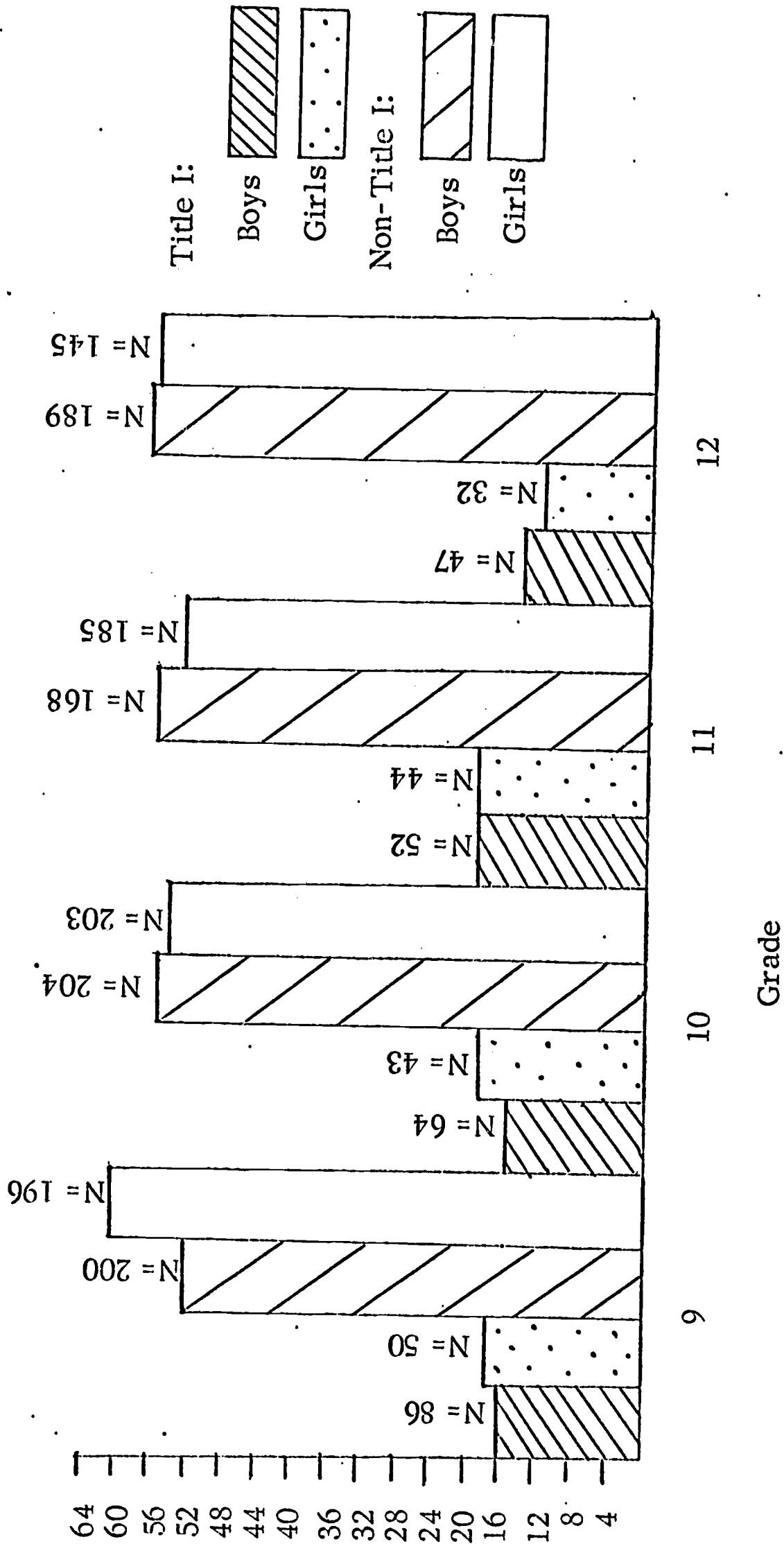

ITED - COMPOSITE SCORES FOR STANDARD METROPOLITAN STATISTICAL AREA 4

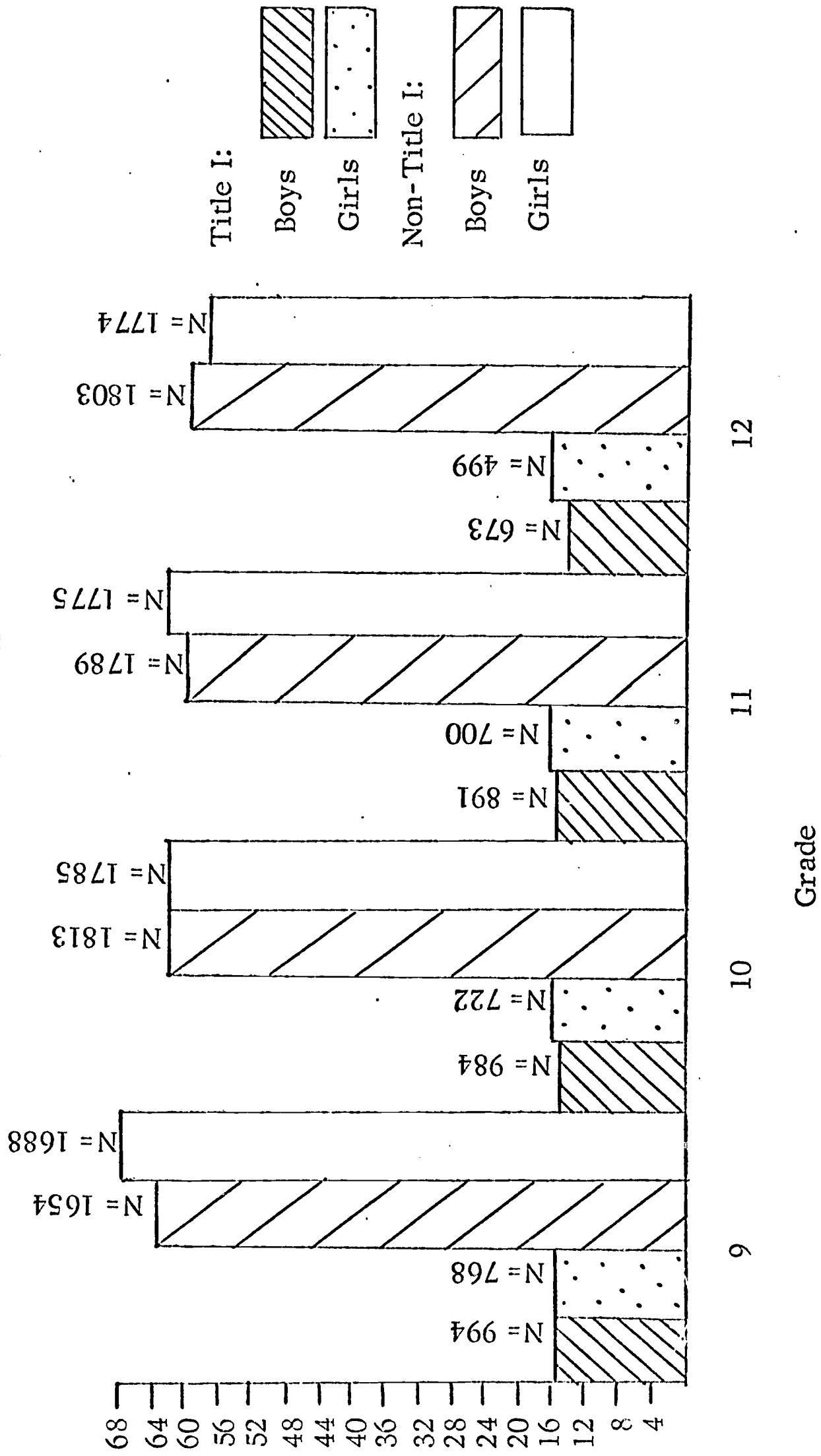
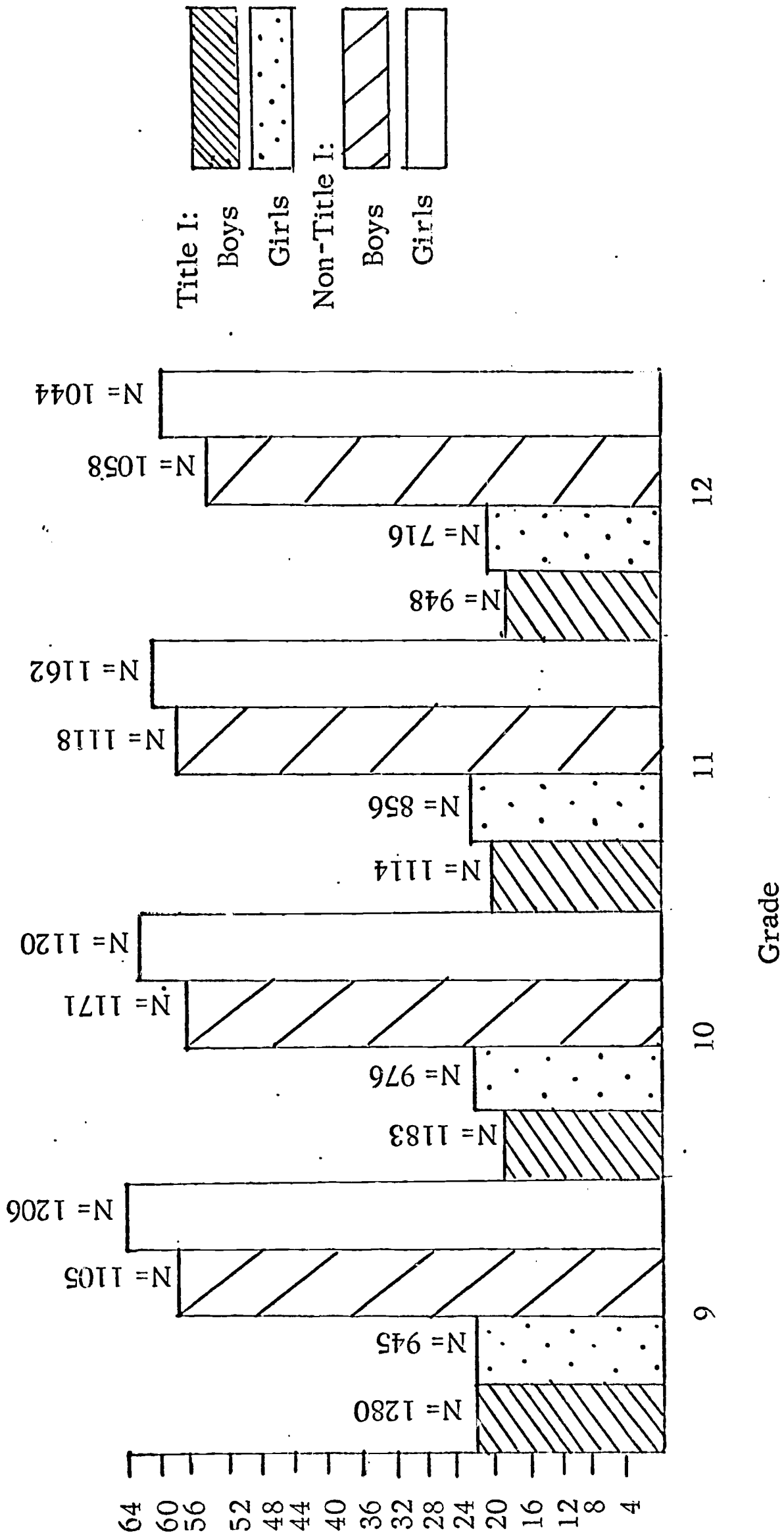

TABLE V

ITED - COMPOSITE SCORES FOR STANDARD METROPOLITAN STATISTICAL AREA 5



It should be noted that at SMSA level 5 in terms of relative performance, the ITED composite scores for Title I pupils were higher than that for any of the other SMSA levels. In other words, the discrepancy between the performance of Title I pupils and the reference samples was least at this SMSA level. The reduced discrepancy can be accounted for, for the most part, by an increase in relative performance of the Title I pupils at SMSA level 5. Stated another way, the SMSA level which involved the largest number of pupils, SMSA level 5, also showed the least discrepancy between the relative performance of pupils from the norm group and the Title I group at the SMSA level.

Composite Scores Versus Reading/Nonreading Objectives

Again, as a result of the preponderance of reading-type objectives listed on Project I applications during the first year of Title I, a table was constructed to compare the distributions of pupils when classified by reading versus nonreading project objectives on the ITED composite scores.

An examination of this table, which graphed the two distributions by sex within grades nine, ten, eleven and twelve, showed that the overall ability of the Title I group tended to be highest at the ninth grade level.

In terms of sex differences, it was interesting that at grade levels eleven and twelve the girls participating in reading projects scored a higher composite score on the ITED than did those not participating in reading projects. At the ninth grade level, the opposite was true. Grade

level ability, as measured by composite scores, showed the expected finding that the educational development of boys at each of the grade levels was not as high as that for girls (Tables XVI, XVII, XVIII).

TABLE XVI
 ITED - COMPOSITE SCORES FOR PUPILS CLASSIFIED IN
 READING AND NON-READING PROJECTS

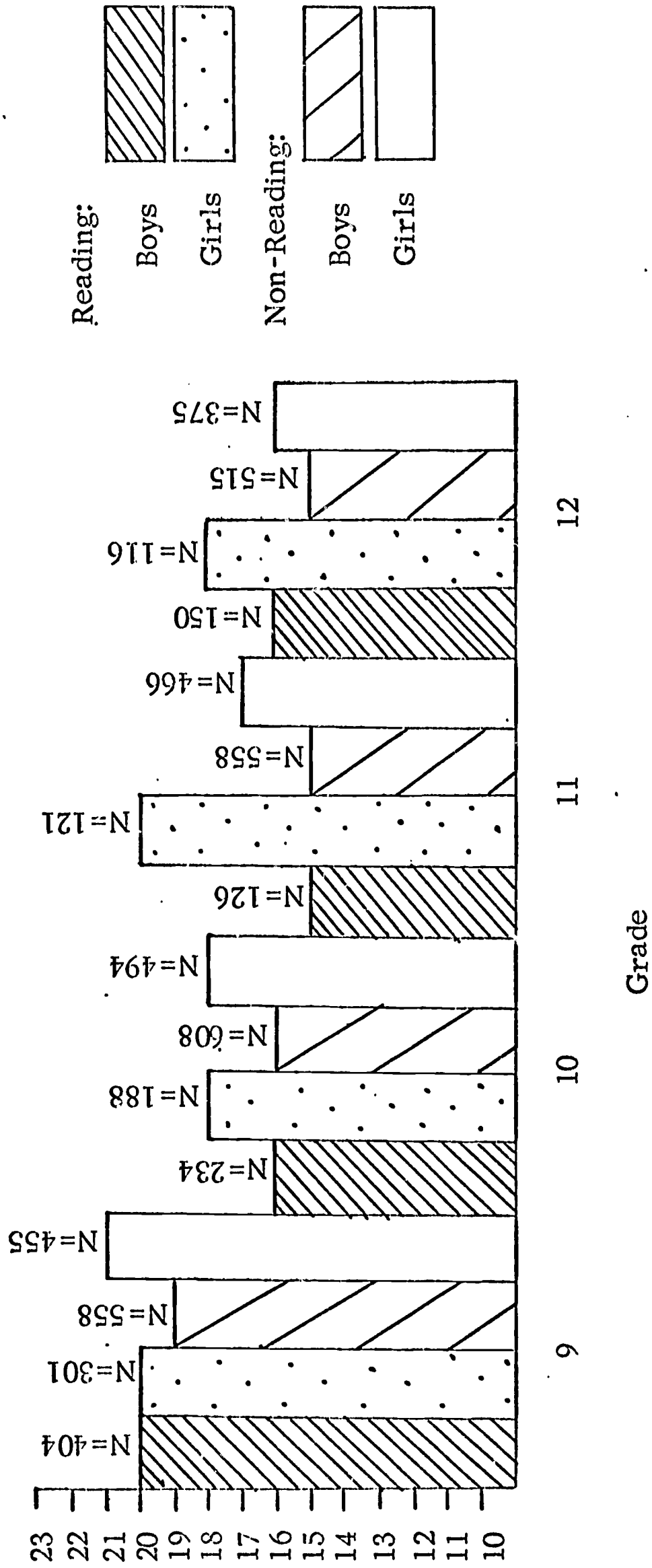

TABLE XVII
COMPOSITE SCORE LEVEL FOR BOYS IN TITLE I PROJECTS: ITED

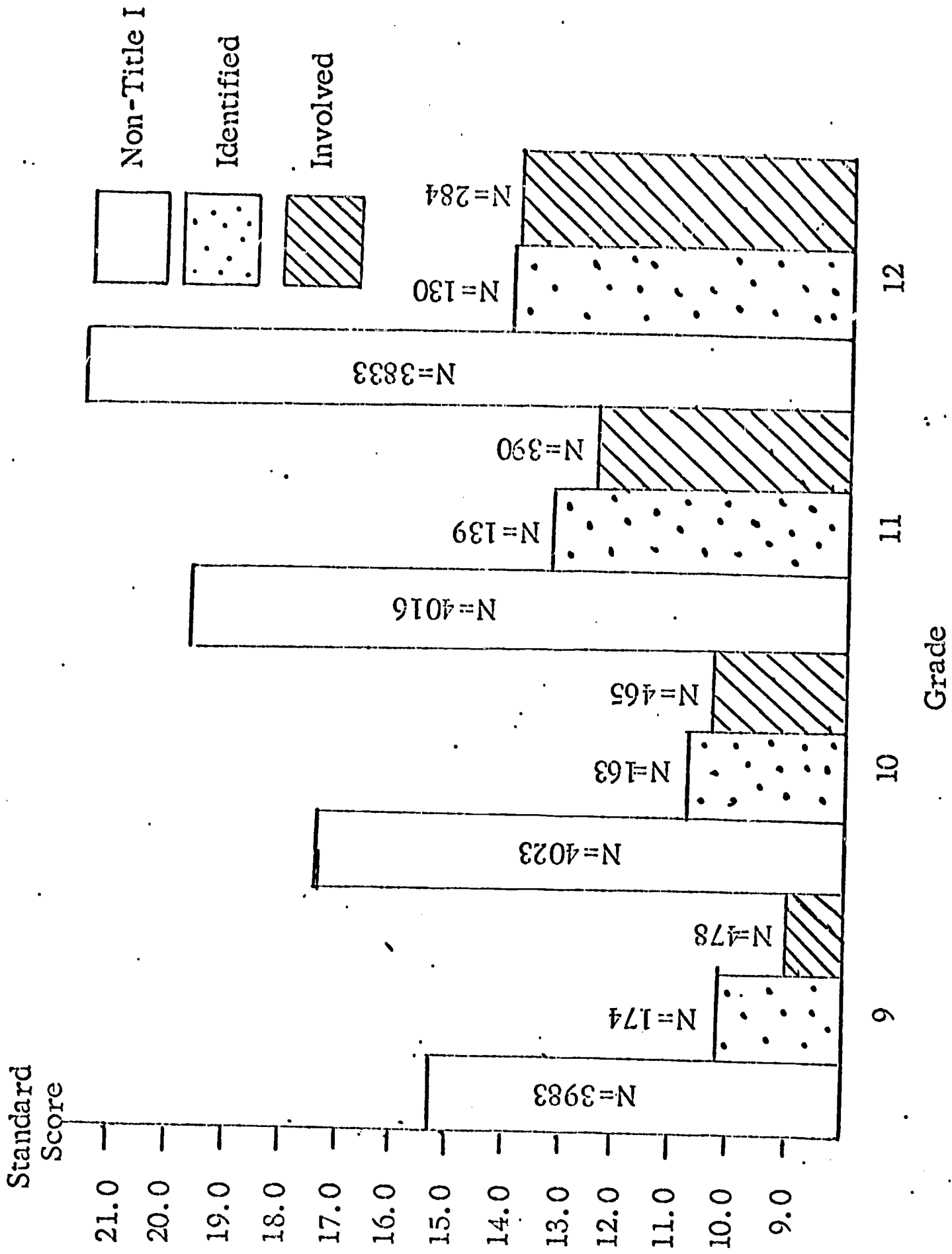
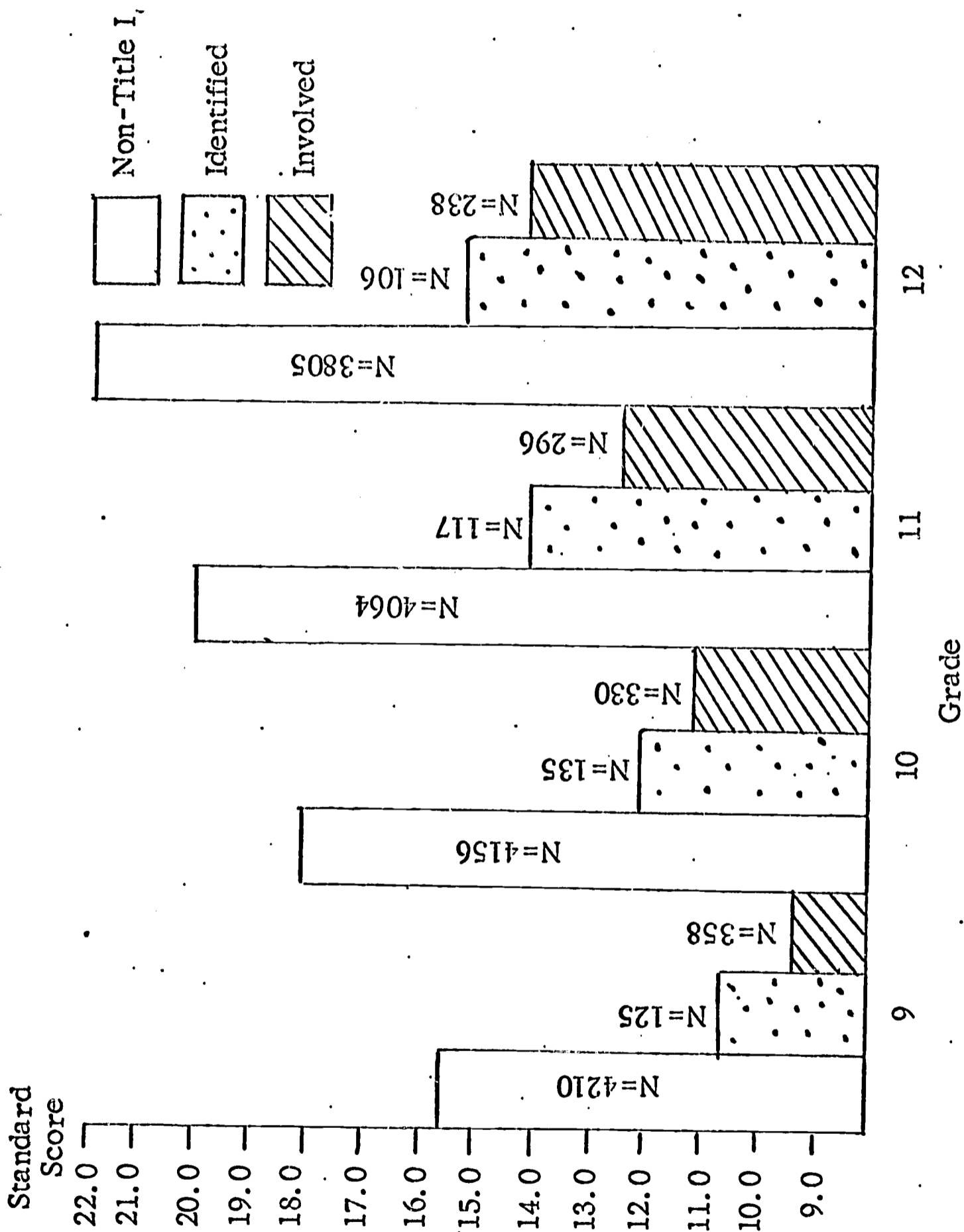

TABLE XVIII
 ITED - COMPOSITE SCORE LEVEL FOR GIRLS IN TITLE I PROJECTS



IOWA TESTS OF BASIC SKILLS

The Iowa Tests of Basic Skills (ITBS) represent a generalized achievement testing series concerned with intellectual skills and abilities. These measures do not provide for specific achievement and content studies but center on the measurement of the basic intellectual skills necessary for success at the particular grade level.

The authors of the tests list three major purposes for the battery. First, the tests are designed to enable teachers and school officials to become quickly acquainted with the educational accomplishment and abilities of their pupils. This is done in order that the educational program can be better adjusted to the individual needs of the pupils in a particular setting. The second major purpose is to supply information for effective pupil guidance. Third, the authors list the provision of objectives and dependable evaluation data as a function of the test.

The organization of content of the Iowa Tests of Basic Skills is reported under five major score categories. Vocabulary (V) consists of 114 items designed to measure the vocabulary of a pupil from grade three through grade nine. As with all subtests of the Iowa Tests of Basic Skills, the items overlap across grade level. Reading (R) comprehension consists of 178 items designed to measure the reading understanding of pupils.

Language (L) skills consist of 402 items divided into four

subclassifications. L-1 (spelling) consists of 114 items while L-2 (capitalization) and L-3 (punctuation) make up 102 items in each subtest. The fourth subcategory of language skills, L-4 (usage), consists of 86 items. Again, we find the overlap of items across grade levels as a standard feature of the test.

Work-study skills (W), the fourth major area of the test, has three subparts. W-1 (mapreading) consists of 89 items; W-2 (reading graphs and tables) include 74 items; and W-3 (knowledge and use of reference material) consists of 141 items. The total content of the subtests under work-study skills contain 304 items.

The fifth major area, arithmetic skills (A), has two subparts. A-1 (concepts) contains 136 overlapping items while A-2 (arithmetic problem solving) contains 96, for a total of 232 items. The total test, grade three through nine, is made up of 1, 232 items and the total administration time for grades three through nine consists of four hours thirty-nine minutes. A complete description of the tests as developed under the Iowa Testing Programs can be found in the manual for administrators provided by the Houghton Mifflin Company of Boston, publishers of the test.

In Appendix B a complete tabulation of the results of Iowa Tests of Basic Skills by SMSA level is provided. The appendix also includes a comparison group for each grade level within SMSA level.

In the body of this report, the tabulations included are for the composite scores on the test by Standard Metropolitan Statistical Areas. These summarizations provide information on Title I participants and a reference population of nonTitle I pupils. The summary tables are for grades three, four, five, six, seven, eight, and nine when applicable.

Composite Scores

The following series of tables represent the comparison of Title I boys and girls with the sample of nonTitle I pupils. For these comparisons the composite scores on the Iowa Tests of Basic Skills were used. The composite score has a reliability coefficient of .97 at grade three and .98 at grades four, five, six, seven and eight. The Iowa Tests of Basic Skills composite scores, in comparison with other achievement measures, are extremely reliable. The reliability figures quoted here are those reported in the manual supplied by the publishers of the test.

Table XIX shows the distribution of composite scores for grades three, four, five and eight from SMSA 1. This table shows that the performance of Title I boys and girls was obviously much lower than that of the respective comparison group at each grade level.

TABLE XIX

ITBS - COMPOSITE SCORES FOR STANDARD METROPOLITAN STATISTICAL AREA I

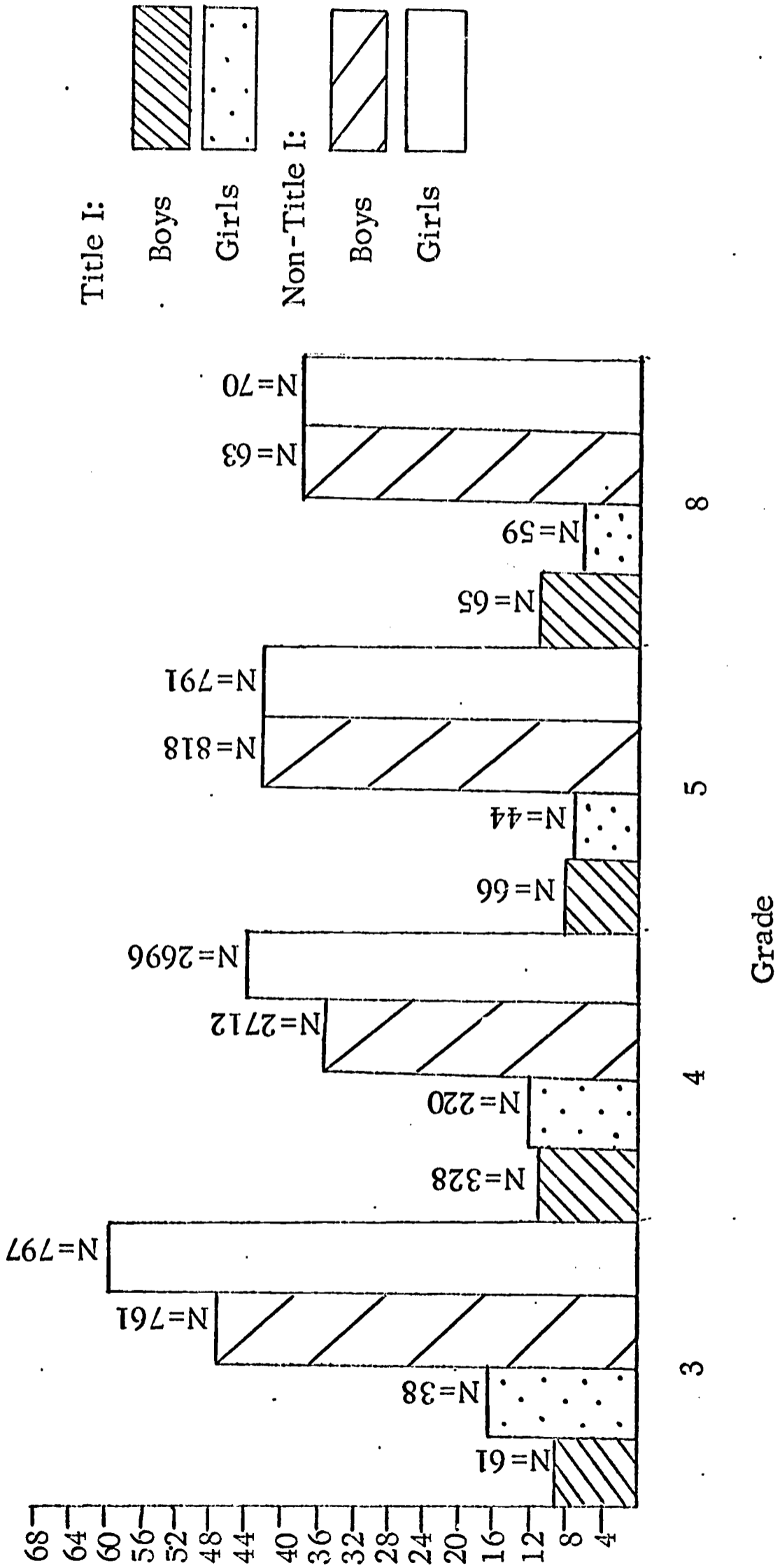

While the number of pupils involved at the third, fifth and eighth grade level of Title I participants was small, it does represent the number of pupils involved from this SMSA area for whom test information was available. In no case, however, was the number of participants so small that meaningful comparisons could not be made. The chi-square (the statistic for differences in distribution) was computed at each grade level and for each SMSA level. In all cases a statistically significant difference between the two groups was found.

At the third grade level (Table XIX) there existed a difference in the performance of boys and girls within Title I projects, as well as a difference between Title I boys and girls and the performance of the norm group. This difference reversed itself at the fifth grade level and the eighth grade level where Title I boys did better than Title I girls on their performance in terms of composite score. The difference between Title I and nonTitle I was consistent across all grade levels shown and favored the nonTitle I group.

After examining the summary table for SMSA level 1, it becomes readily apparent that the performance of Title I pupils was decidedly poorer than that of a representative group not included in Title I activities.

On the lefthand margin of the table the figures 4 through 68 represent the range of percentile ranking on the composite score using State of Iowa norms. One would expect typical performance for the

non-Title I group to be approximately at the 50 percent level. The performance of the Title I group, on the other hand, never exceeded the sixteenth percentile for any grade when either boys' or girls' performance was plotted.

For SMSA level 2 (Table XX), the composite score results were available for grades three, four, five, seven and eight. Here, the comparison between the performance of Title I pupils and the comparison sample was also obvious. At two of the grade levels, four and eight, the number of pupils involved in Title I activities dropped below ten for girls. If these figures were presented alone, i.e., without the benefit of other SMSA level comparison groups, one might be led to the conclusion that the differences were not very reliable because of the small number of cases involved. But the discrepancy shown here was consistent with those for all other SMSA levels and the composite figures do represent large groups of pupils. Therefore, the difference in performance on the Iowa Tests of Basic Skills shown for Title I pupils and a representative sample was obviously great and consistent with the expectation of program involvement.

The composite scores on the Iowa Tests of Basic Skills for SMSA level 3, SMSA 4 and SMSA 5 are presented in Tables XXI, XXII, and XXIII.

These three tables are discussed together as the discrepancy

TABLE XX

ITBC - COMPOSITE SCORES FOR STANDARD METROPOLITAN STATISTICAL AREA 2

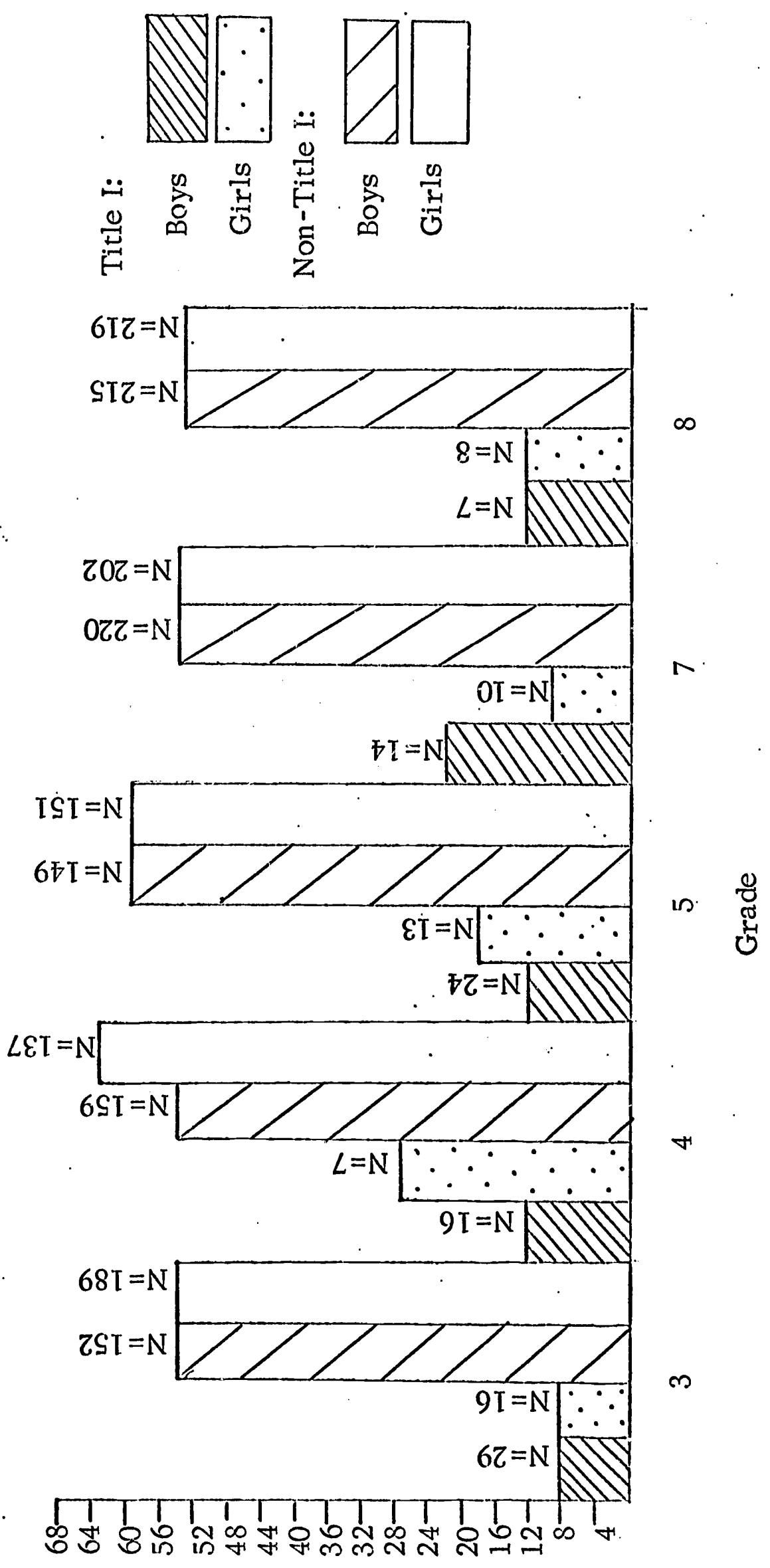

TABLE XXI
 ITBS - COMPOSITE SCORES FOR STANDARD METROPOLITAN
 STATISTICAL AREA 3

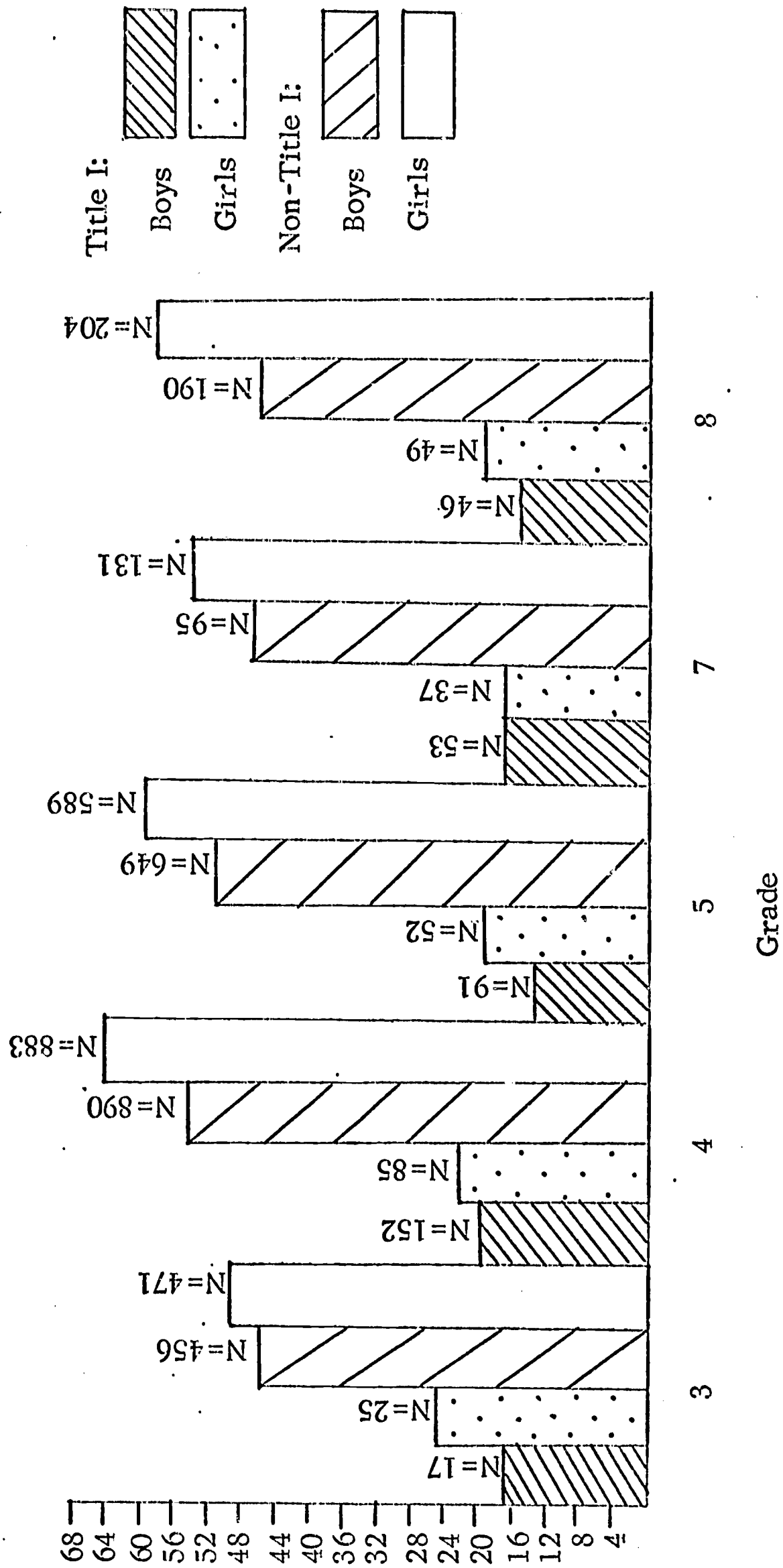

TABLE XXII

ITBS - COMPOSITE SCORES FOR STANDARD METROPOLITAN
STATISTICAL AREA 4

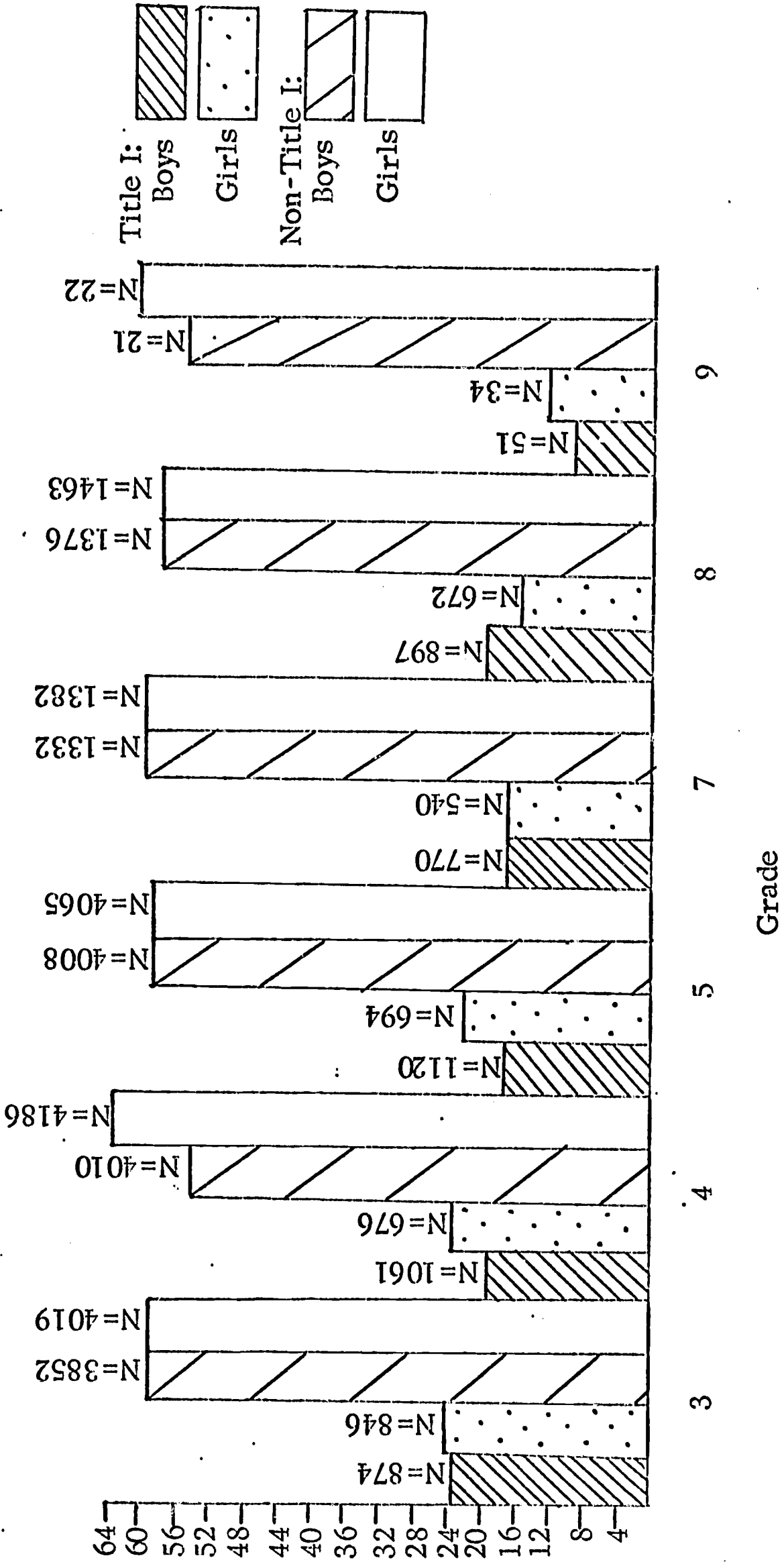
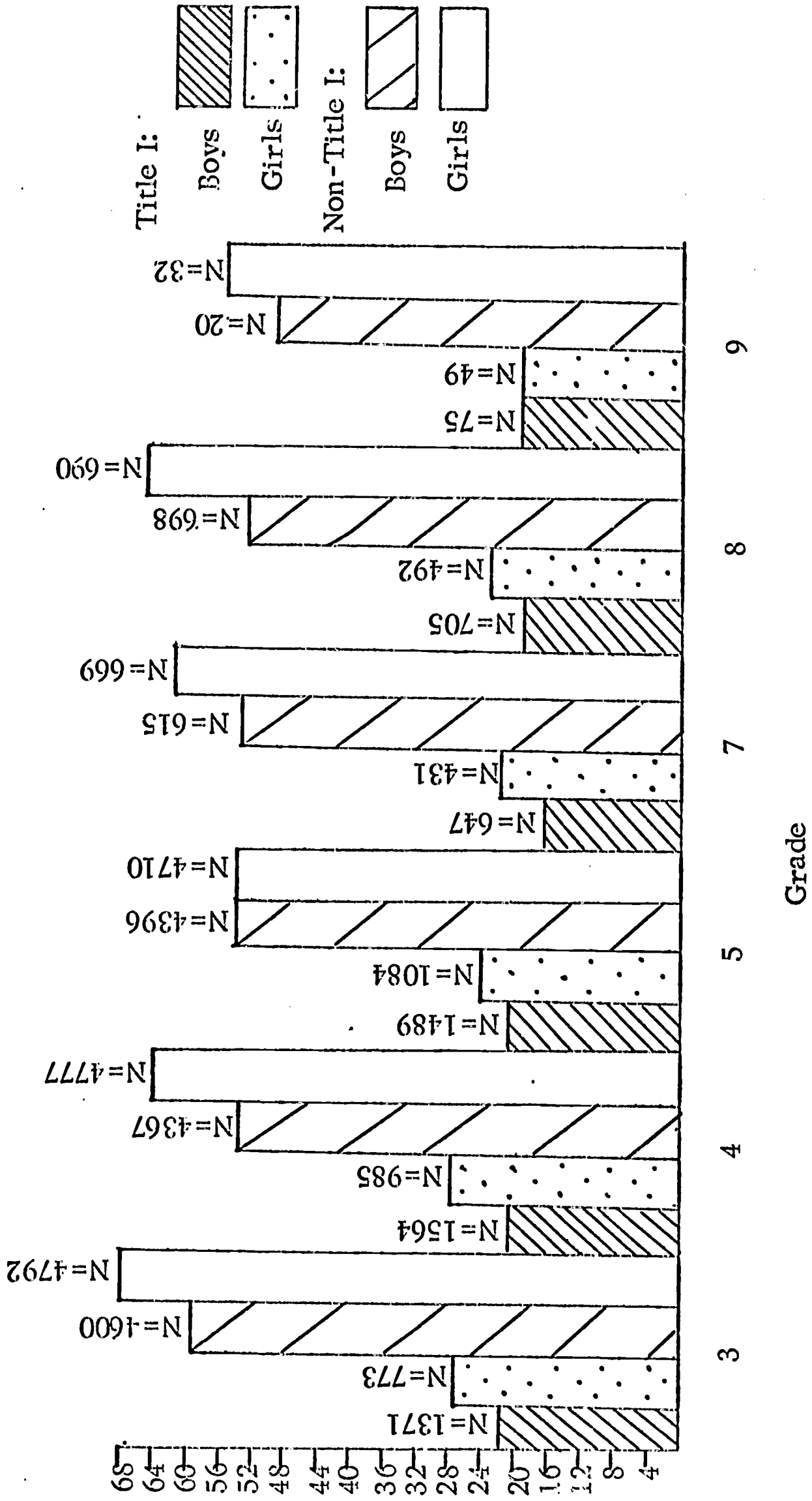

TABLE XXIII
 ITBS - COMPOSITE SCORES FOR STANDARD METROPOLITAN
 STATISTICAL AREA 5



between performance of Title I pupils and the referent group of pupils is similar across all three SMSA levels.

Consistent with the distribution of grant monies and pupils represented by SMSA levels in Part I of this report, the number of pupils represented in Title I at SMSA levels 4 and 5 is considerably larger than that reported for the other three SMSA levels. In terms of the discrepancy in composite scores for Title I boys and girls, on all but one of the grade levels the performance of girls exceeded that of boys. The exception was grade eight for SMSA level 4. At this grade level the performance of boys exceeded that of girls.

In terms of the referent population, there was no case where the performance of boys exceeded that of girls. This finding was consistent with information the manual provided by the publishers which emphasizes that across the elementary grade levels the performance of girls should be expected to exceed that of boys in composite score results.

Composite Scores Versus Reading/Nonreading Objectives

Table XXIV represents a comparison of the composite scores on the Iowa Tests of Basic Skills for projects stated reading-type objectives and other projects simply titled nonreading projects. The purpose of this comparison was to examine any possible relationship between a project stating a reading objective as against a nonreading objective to the composite score on the ITBS.

TABLE XXIV
 ITBS - COMPOSITE SCORES FOR PUPILS CLASSIFIED IN READING
 AND NON-READING PROJECTS

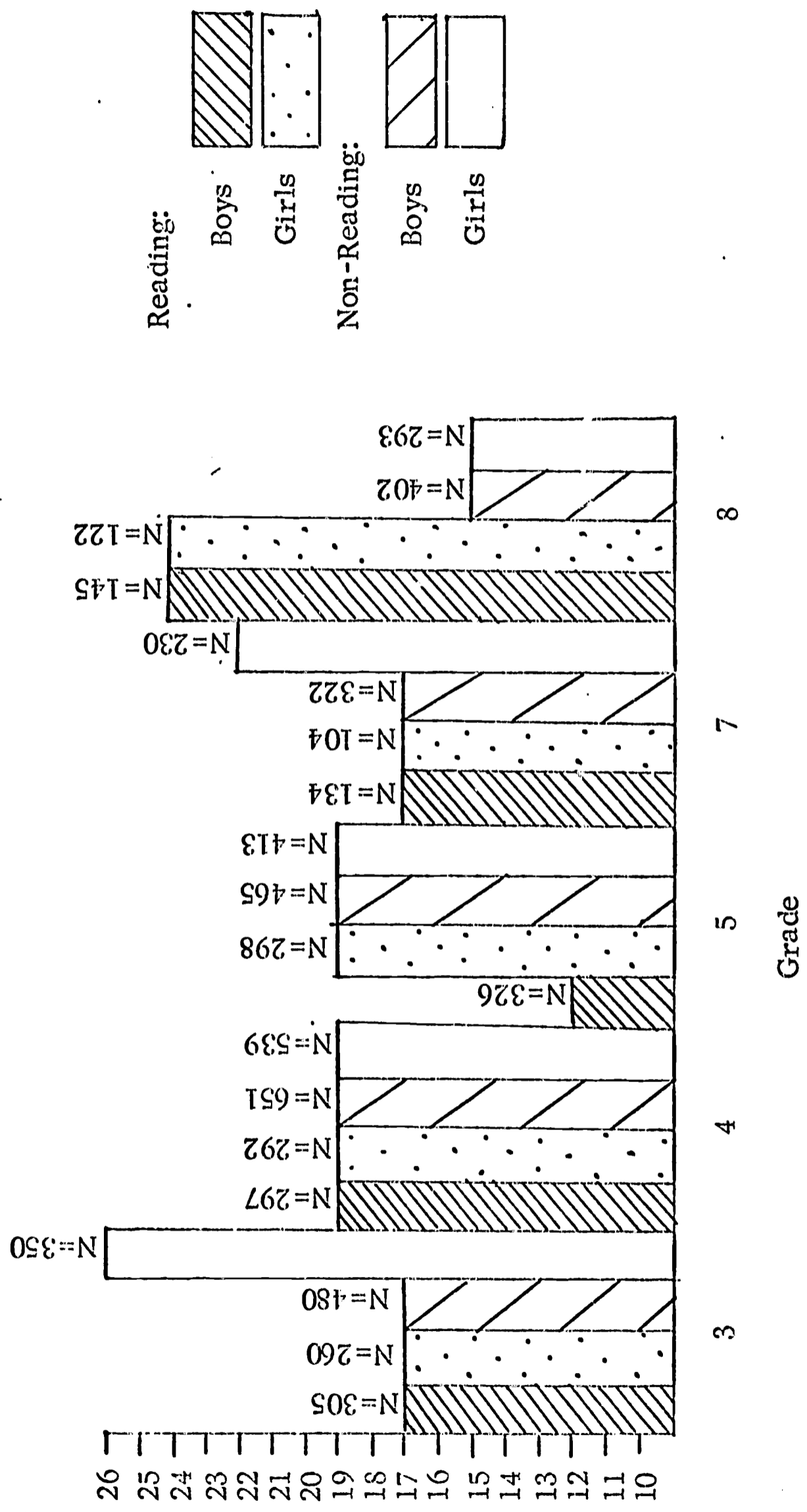

An examination of the table shows that performance in terms of composite score on the ITBS for the reading projects versus the nonreading projects did not clearly differentiate the two groups. For example, at the third grade level, reading projects showed a comparable composite score for boys and girls. Nonreading projects showed a wide discrepancy in score between the sexes. The performance of girls in nonreading projects exceeded that for boys on both a statistical and visual dimension, but the relative composite score for boys in nonreading projects was the same as that for boys and girls in reading projects at the third grade level.

At the fourth grade level, the scores for pupils in reading and nonreading projects were nearly identical. They are represented on the graph as a continuous line for the four groups. One would expect from the published norms for the test that the performance of girls would exceed that of boys in both the reading and nonreading groups. This was not the case.

At the fifth grade level, the performance of boys involved in reading projects was significantly lower than that for girls in projects and also for both boys and girls not involved in reading projects.

At the seventh grade level, the performance of girls not involved in projects was greater than for the other three groups shown. The pattern at grade seven was very similar to that shown for grade three with the exception of the discrepancy between girls in nonreading projects and all other pupils shown at grade seven. This was not as

great as it was at grade level three.

At the eighth grade level, the composite score for boys and girls involved in reading projects was similar. Also, it was significantly greater than the composite score for boys and girls not in reading projects at the same grade level. One would expect the opposite to be true.

In terms of the overall appearance of the table, the performance of girls exceeded that of boys at only two of the grade levels. The performance of pupils in reading programs exceeded that of pupils in nonreading programs at the eighth grade level. There was no clear-cut trend for any grade level to show a consistent relationship to composite score achievement and involvement in reading-type projects.

Tables XXV and XXVI present the composite score distribution for nonTitle I, Title I identified and Title I involved boys and girls on the ITBS for grades three, four, five, six, seven and eight.

The table for boys, Table XXV, shows clearly the gain in grade equivalent as pupils progress through school. The widening gap between nonTitle I boys and Title I involved boys is also evident. From the table, Title I identified pupils appear to keep a better pace in terms of relative standing, than do their Title I involved counterparts. Clearly Title I boys begin with a grade equivalent handicap which grows as they progress through school. The bar graph for the three groups of girls (Table XXVI) showed a similar trend as that noted for boys.

TABLE XXV

ITBS - COMPOSITE SCORE LEVEL FOR BOYS IN TITLE I PROJECTS

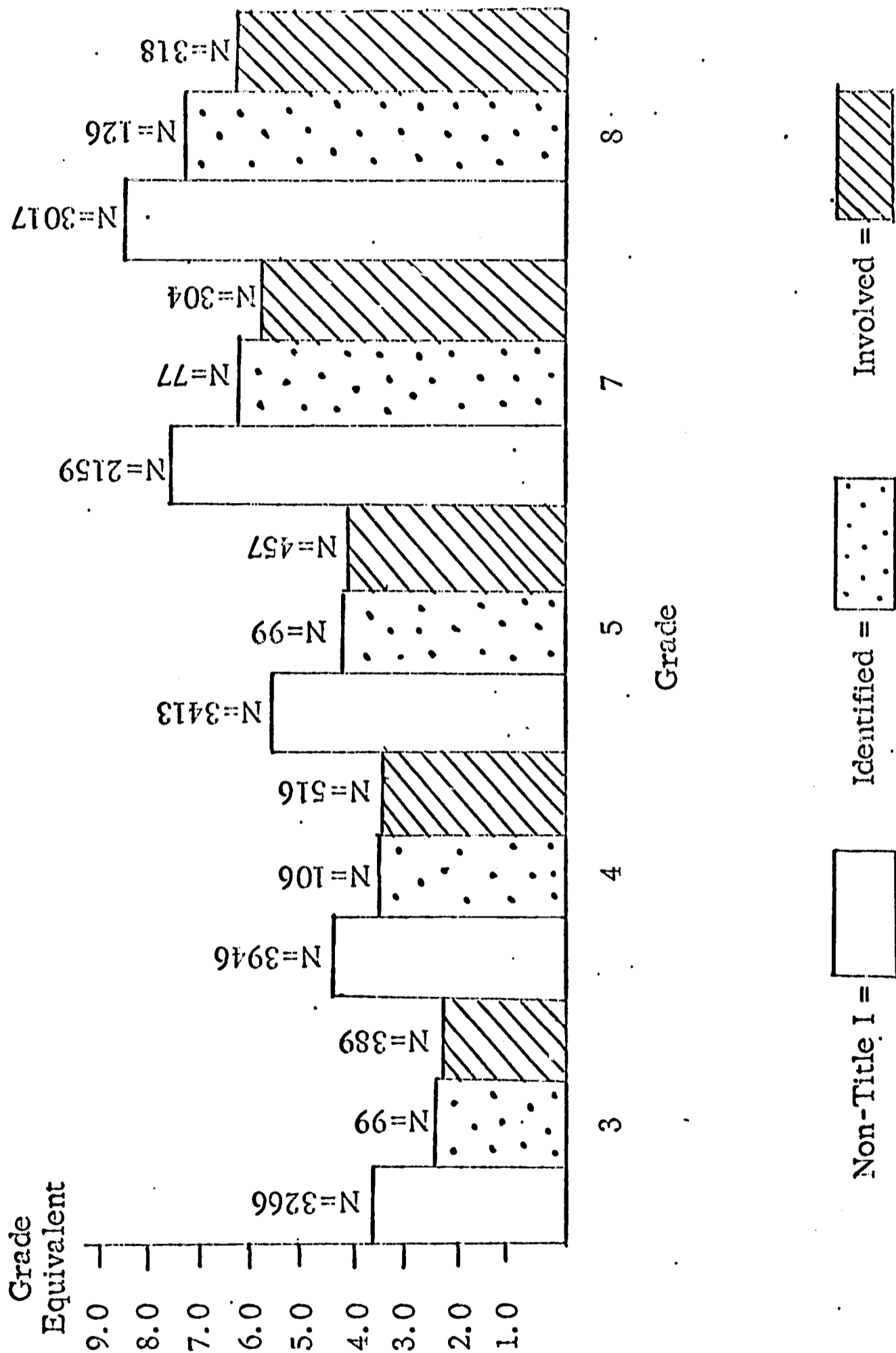
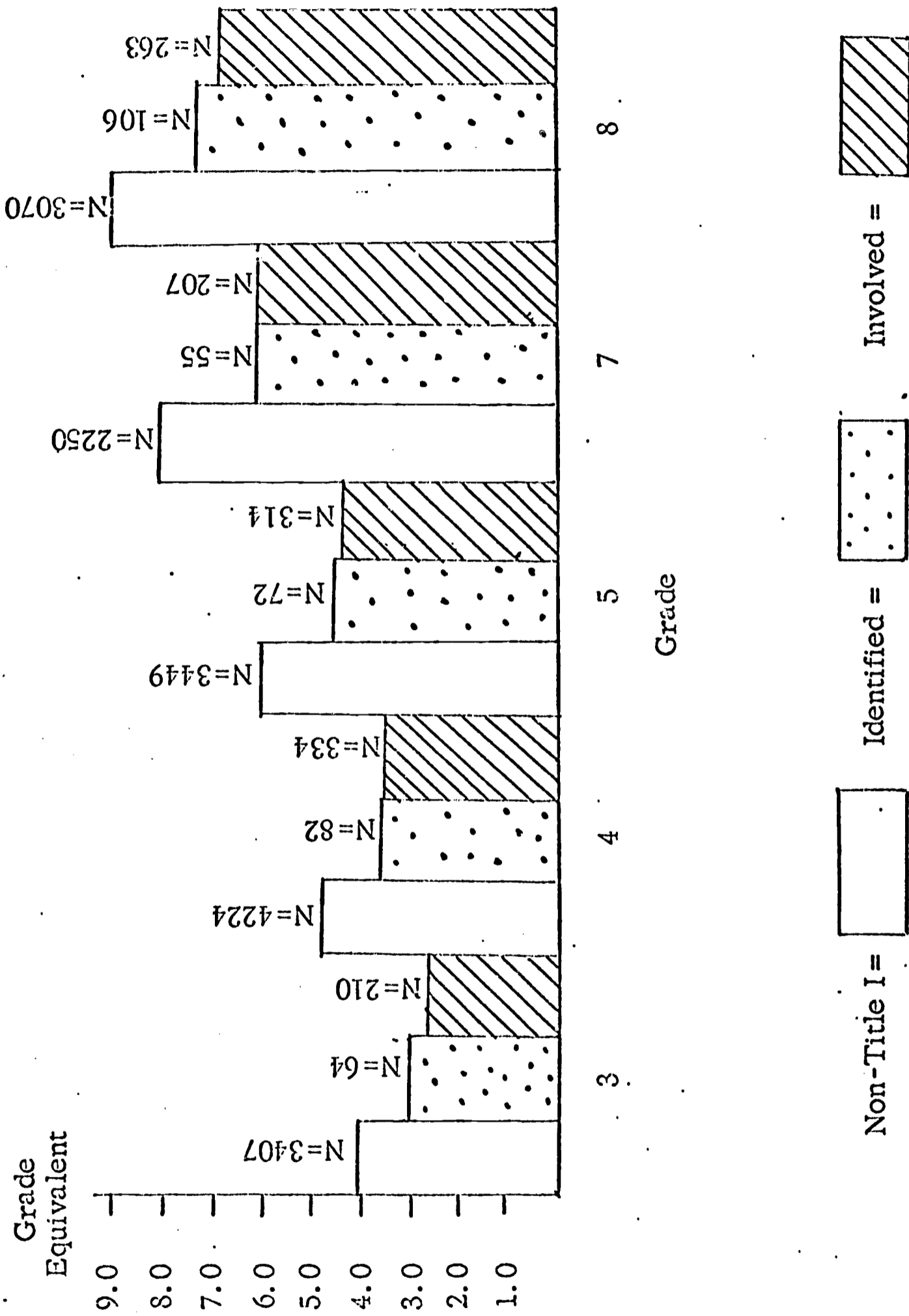

TABLE XXVI

ITBS - COMPOSITE SCORE LEVEL FOR GIRLS IN TITLE I PROJECTS



But, in the case of girls, the discrepancy between those identified for Title I funds was not as great as that for boys at the higher grade levels. The tendency for the gap between Title I girls and the norm group to widen as grade level progressed, while not as pronounced as that for boys, did again appear.

From the two tables one would be led to conclude that the selection process for involvement tended to favor the more needy boys to a greater extent than it did girls on the basis of their ITBS composite scores.

PART IV

In the first three parts of this report an attempt was made to provide information on the first year's operation of Title I programs in terms of the administrative context, administrative communications, and the staff, pupils, programs and test information related to the established programs. An attempt is made in this part to provide indications of possible relationships and significant variables in completing the evaluation of Title I efforts. This section is to be viewed as a first attempt - an interim report - on the process of evaluating Title I activities in the State of Iowa.

Part IV has been divided into four major sections. The first section describes certain relationships between pupil achievement as defined by mark point average and responses to CardPac Pupil Inventory items. The objective was to point out significant differences between the target population and regularly enrolled pupils when both response and achievement were juxtapositioned.

The second section looks at the linear relationship between significant items of pupil information and school achievement. The method for this section was multiple correlation. The objective was to delineate those variables which contributed significantly to the criteria of school achievement as measured by mark point average for the Title I group and compare them to a referent group of pupils for compatibility.

The third section looks at certain variables in an attempt to

examine relationships on multiple dimensions. The technique in this section was a Discriminate Function Analysis. The criterion for this function was the ability to maximize the differences between Title I participants, Title I identified but not participating, and what were called regular pupils on multiple criteria. The objective for this section was to ascertain the contribution of items of information in discriminating pupils into the three groups.

The fourth section of Part IV of the report examines the differing relationships between groups of pupils on certain relevant variables. The form employed was graphic presentations of the relationships. The objective of this section was to illustrate directional differences on variables when plotted for the Title I involvement. In this section, the criterion group again was the nonTitle I high school pupils.

IOWA PUPIL INVENTORY COMPARISONS

During the 1965-66 academic year, the Iowa Educational Information Center administered a Pupil Inventory to all public school pupils at the secondary level in the state (a copy of the Pupil Inventory is included as Appendix C). As was previously stated in Part III of the report, it was possible to go back to the tape file created for pupil responses to the inventory and identify the Title I participants who took the inventory. The comparisons shown in this section are shown to further clarify the response contrast between Title I pupils and the norm group when matched with other significant bits of pupil information.

In all, 22,609 Title I pupil responses were matched. This figure represents 82.4 percent of the possible response total. The 17.6 percent loss figure was felt to be accounted for by absenteeism on the day of administration and/or a failure to respond to either a particular item or series of items. An examination of the data led to the conclusion that the figures shown in the series of tables are representative of the Title I population at the particular grade levels included in the comparisons.

The comparison group represents the state-wide distribution for each response and was arrived at through the processing of all pupil responses from school districts within the state. This comparison group then provides a base line for the response patterns shown in the tables. Responses are shown for the two groups.

The mean mark-point average for the two groups along with the standard deviation is also shown to assist the reader in drawing inferences. We then had a table showing the response pattern by number and percent to each possible response on a selected item of information for the two groups along with the associated mark-point averages of the groups.

The tables show responses to the following items by grade level for Title I pupils and the statewide population:

Pupil Inventory

1. On the average, during the school year (not counting summer vacation) how many hours per week do you work for which you are paid? (Allowance, food and clothing provided by parents are not considered pay.)
2. On the average, how many hours each week do you spend doing homework outside of school?
3. How many unpleasant experiences have you had with other pupils in the school?
4. How do your teachers view you?

While it may be superfluous to point out that all percentage differences in response for the two groups shown in the tables are significant in cases where such large numbers of pupils are involved, it should be pointed out that the chi-square statistic for differences in response pattern has been computed for each item. In every case, the differences reflected in the percentage distributions represent statistically significant differences. In fact, every table included reflects distribution differences

one would not expect to find once in a thousand cases.

When large numbers of cases are involved, in addition to differences being statistically significant, they must also be meaningful in the sense of being interpretable. The reader is cautioned before examining the tables that while differences of one percentage point may be statistically significant when comparing large groups of pupils, it is often very difficult to interpret the meaning of such differences.

The most generalizable inferences that can be drawn from the data presented were made from the more obvious percentage differences between the two groups that were consistent in direction across grade levels. Also, the shifts that occurred in percentage distributions across grade level presented significant bits of information suggesting the changes that occur in the attitude of pupils at different grade levels. But, any such inferences are subject to the limitations of cross-sectional data. In the final report, the validation of these findings will be possible.

How many hours a week do you work for which you are paid?

Table I shows the relationship between responses of the two groups to the item "On the average, during the school year, how many hours a week do you work for which you are paid?" Down the left hand column of the table the possible responses by grade level are shown. Directly to the right, the number of respondents by response category and the percentage this number represents of the total respondents to the item for Title I and

MEAN MARK-POINT AVERAGES AND STANDARD DEVIATIONS OF MARK-POINT AVERAGES
FOR PUPILS CLASSIFIED BY THEIR RESPONSES TO SELECTED ITEMS
OF THE CARDPAC INVENTORY

ITEM: On the average, during the school year, how many hours a week do you work for which you are paid?

Response	Number of Pupils		Mean MPA		Standard Deviation	
	N	%	Title I	State	Title I	State
GRADE 7						
None	1169	42.9	6818	45.9	1.54	2.37
1-5	757	27.8	4763	32.0	1.47	2.35
6-10	413	15.1	2125	14.3	1.53	2.24
11-15	172	6.3	783	5.3	1.51	2.09
16-20	85	3.2	376	2.5	1.47	2.02
21 or more	128	4.7	0	0	1.37	0
TOTAL	2724		14865			
GRADE 8						
None	1248	35.4	7000	38.6	1.60	2.37
1-5	1041	29.6	6357	35.1	1.61	2.37
6-10	641	18.2	3082	17.0	1.52	2.25
11-15	253	7.2	1168	6.4	1.58	2.13
16-20	131	3.7	531	2.9	1.46	2.09
21 or more	207	5.9	0	0	1.56	0
TOTAL	3521		18138			
GRADE 9						
None	1815	35.3	10988	39.3	1.78	2.37
1-5	1461	28.4	9330	33.4	1.78	2.40
6-10	826	16.0	4613	16.6	1.72	2.22
11-15	410	8.0	1897	6.8	1.70	2.15
16-20	268	5.2	1098	3.9	1.55	2.03
21 or more	367	7.1	0	0	1.50	0
TOTAL	5147		27926			

TABLE I (continued)

ITEM: On the average, during the school year, how many hours a week do you work for which you are paid?

Response	Number of Pupils		Mean MPA		Standard Deviation			
	N	%	Title I	State	Title I	State		
GRADE 10								
None	1446	33.3	9842	38.9	1.74	2.35	0.67	0.79
1-5	1015	23.4	7473	29.5	1.73	2.40	0.65	0.77
6-10	698	16.0	4064	16.0	1.63	2.20	0.63	0.76
11-15	368	8.5	2166	8.6	1.60	2.14	0.62	0.74
16-20	340	7.8	1759	7.0	1.52	2.04	0.61	0.75
21 or more	479	11.0	0	0	1.53	0	0.57	0
TOTAL	4346		25304					
GRADE 11								
None	1142	30.2	8948	38.5	1.85	2.45	0.67	0.69
1-5	719	19.0	5687	24.5	1.83	2.48	0.67	0.71
6-10	546	14.4	3613	15.5	1.75	2.30	0.61	0.73
11-15	419	11.1	2613	11.2	1.73	2.25	0.64	0.73
16-20	367	9.7	2375	10.3	1.63	2.15	0.62	0.70
21 or more	592	15.6	0	0	1.54	0	0.55	0
TOTAL	3785		23236					
GRADE 12								
None	931	30.2	8206	40.4	2.05	2.65	0.66	0.74
1-5	518	16.8	4213	20.7	2.10	2.66	0.68	0.73
6-10	416	13.5	2959	14.6	1.93	2.48	0.69	0.74
11-15	322	10.4	2386	11.7	1.88	2.43	0.67	0.71
16-20	320	10.4	2555	12.6	1.96	2.38	0.62	0.69
21 or more	579	18.7	0	0	1.78	0	0.57	0
TOTAL	3086		20319					

the statewide sample are shown. To the right of the actual response patterns, the mean mark-point average for Title I pupils and the statewide sample are presented along with the standard deviations of mark-point average for the two groups.

Looking first at the seventh grade response, it is easily seen that Title I participants averaged many more hours of work for which they were paid than did the statewide sample. One significant feature of the distribution at the seventh grade level shows that 128 or 4.7% of the Title I pupils worked 21 or more hours per week. The relevance of this figure is even more apparent when compared with the zero response for pupils from the statewide sample to the category 21 or more hours.

Moving to the right and comparing the mean mark-point average of the two groups, it becomes fairly obvious that the Title I pupils begin with a lower mark-point average than the statewide sample and as they work they do not profit in terms of mark-point average from the intrusion of work on their time. While this is also true for the statewide sample, the fact remains that "regular" pupils begin at a much higher level of mark-point average and the detrimental effects of working still leave them much better off than the Title I group.

Again at grade eight, the difference in the percentage of Title I pupils who work a significant number of hours per week can be noticed.

Of the two groups, 16.8% of the Title I recipients worked eleven or more hours per week, while in contrast only 9.3% of the statewide sample showed this degree of involvement in work for pay outside of school hours. Again, the tendency was for Title I pupils to start with a lower mark-point average and show a similar decrease in mark-point average as they become more involved with outside work. The standard deviations of the two groups are comparable across response categories. In all of the tables, the possible responses to the item are none, one to five hours, six to ten hours, and twenty-one or more hours, thus allowing for six possible response categories.

At grade nine, the same trend as for grades seven and eight occurred. While 20.3% of the Title I pupils work eleven or more hours per week, only 10.7% of the statewide sample were thus involved.

At grade ten, the trend held. While the percentage of the total responding at the grade level increases in terms of time spent working, the percentage for Title I pupils far exceeds that for the statewide sample. For example, when we look at eleven or more hours of work for pay, 27.3% of the Title I recipients at the tenth grade level fall in this category compared with only 15.6% of the state total. Again we see the tendency for Title I pupils to have lower mark-point averages than those of the comparison group.

The trend continues through grades eleven and twelve and becomes even more pronounced. While 36.4% of the Title I participants worked eleven or more hours per week, only 21.5% of the comparison group responded in this manner at the eleventh grade level. Of the twelfth grade Title I pupils, 39.5% as contrasted to only 24.3% of the state sample worked eleven or more hours per week.

The general tendency across grade levels was for Title I pupils to both begin the comparisons with a lower mark point average and be more involved in excessive outside work for pay which further handicapped them in academic competition. This trend was apparent at every grade level and represented a significant relationship between the response to this item and mark point average for the two groups.

How do your teachers view you?

When the responses of the two groups to the question, "How do your teachers view you?" were analyzed, another striking difference between the groups appeared. Table II contrasts the results by grade level for the responses of the two groups. On this particular question, a pupil had five response possibilities. He could mark himself a top pupil, a good pupil, an average pupil, below average, or a very poor pupil. Again, on the right hand side of the table the mean mark point average for Title I pupils and the state sample are presented along with the standard deviation of mark point average for the two groups.

The responses at the seventh grade level showed that 26.2%

TABLE II

ITEM: How do your teachers view you?

Response	Number of Pupils		Mean MPA		Standard Deviation	
	Title I N	State N	Title I %	State %	Title I	State
GRADE 7						
A top pupil	29	819	1.1	5.3	1.46	3.42
A good pupil	202	4313	7.4	28	1.98	2.86
An average pupil	1772	8679	65.3	56.3	1.62	2.10
Below average	586	1322	21.6	8.6	1.12	1.38
Very poor pupil	124	271	4.6	1.8	0.92	1.17
TOTAL	<u>2713</u>	<u>15404</u>				
GRADE 8						
A top pupil	41	1055	1.2	5.6	1.90	3.33
A good pupil	356	5819	10.2	31	2.28	2.86
An average pupil	2283	10135	65.6	54	1.64	2.06
Below average	680	1514	19.5	8	1.12	1.35
Very poor pupil	121	264	3.5	1.4	0.98	1.30
TOTAL	<u>3481</u>	<u>18787</u>				
GRADE 9						
A top pupil	58	1495	1.1	5.1	2.00	3.37
A good pupil	488	8531	9.5	29.2	2.41	2.88
An average pupil	3577	16700	70	57.2	1.78	2.06
Below average	847	2134	16.6	7.3	1.23	1.38
Very poor pupil	143	347	2.8	1.2	1.12	1.36
TOTAL	<u>5113</u>	<u>29207</u>				

TABLE II (continued)

ITEM: How do your teachers view you?

Response	Number of Pupils		State N	%	Mean MPA		Standard Deviation	
	Title I N	%			Title I	State	Title I	State
GRADE 10								
A top pupil	48	1.1	1351	5	1.91	3.42	1.05	0.70
A good pupil	342	7.9	7831	28.7	2.34	2.88	0.69	0.55
An average pupil	2832	65.6	15239	55.8	1.76	2.03	0.56	0.56
Below average	954	22.2	2487	9.1	1.25	1.35	0.51	0.52
Very poor pupil	139	3.3	383	1.4	0.98	1.32	0.62	0.78
TOTAL	4315		27291					
GRADE 11								
A top pupil	48	1.3	1476	5.6	2.24	3.39	1.02	0.66
A good pupil	313	8.3	8269	31.5	2.50	2.87	0.73	0.54
An average pupil	2504	66.7	14045	53.5	1.81	2.07	0.55	0.54
Below average	763	20.4	2102	8.1	1.31	1.43	0.48	0.52
Very poor pupil	125	3.3	351	1.3	1.23	1.38	0.57	0.66
TOTAL	3753		26243					
GRADE 12								
A top pupil	49	1.6	1649	6.9	2.70	3.48	1.04	0.59
A good pupil	319	10.5	8074	33.8	2.62	2.98	0.64	0.52
An average pupil	2104	69	12432	52	1.99	2.20	0.55	0.55
Below average	524	17.2	1495	6.3	1.45	1.54	0.53	0.53
Very poor pupil	55	1.7	230	1	1.41	1.71	0.59	0.70
TOTAL	3051		23880					

of the Title I respondents saw themselves as below average or very poor pupils while 10.4% of the statewide distribution responded in this manner. When the responses of the pupils are compared to the mark point average of pupils at the same response level, it can be seen that they are relatively realistic estimations of performance in terms of mark point average at the respective levels. The striking feature of the table was that Title I pupils did, in fact, far outnumber the state group in degree of representation at the lower end of the continuum. For the most part, their perceptions were realistic.

At the eighth grade level the response pattern likewise showed the decided shift of Title I pupil responses toward the less satisfactory or less positive evaluation of their performance in school. Twenty-three percent of the Title I pupils saw their teachers viewing them as below average or very poor. This was in contrast to only 9.4% of the state group who viewed themselves in this manner.

When one moves to the right and compares the mark point average of the two groups, it can readily be seen that there is a relationship between their estimations of their teachers' views of their performance in school and the groups' mark point average. Again, the difference in the distribution of Title I recipients and the statewide average is clearly evident.

At grade nine, the same tendency also holds as 19.4% of the Title I pupils viewed themselves below average to the very poor, while only 8.5% of the state distribution saw themselves in this light.

Across all of the mark point average distributions for the three grades, it can be seen that as pupils progress in school the Title I group tends to do better. This tendency may in part be offset by the fact that the state distribution also tends to get better as they progress in school. Perhaps selective attrition is operating on both groups. This becomes more clearly evident at the tenth, eleventh and twelfth grade levels. Here again the top pupils from the state distribution have significantly higher mark point averages than do the Title I pupils who see themselves as good pupils as contrasted to top pupils.

Looking again at those pupils from both groups who see themselves as below average to very poor pupils, at the tenth grade level 25.5% of the Title I pupils, as contrasted to 10.5% of the statewide sample, rate themselves in this category. The tendency is repeated at the eleventh grade level where 23.7% of the Title I pupils see themselves as below average to very poor in the eyes of their teachers, while only 9.4% of the statewide distribution respond in this manner. However, the difference in mark point average for the Title I group and the statewide distribution becomes less obvious. While these last figures are probably indirect realistic estimates of how these pupils view themselves, the difference in mark point average is not as apparent. At the twelfth grade level, 18.9% of the Title I recipients saw themselves as below average or very poor in school while only

7.3% of the state distribution saw themselves in this light.

One of the most salient generalizations from examining the tables showing the response to the question "How do your teachers view you?" comes from finding that a significant number of Title I pupils (representing over 1% of the total distribution) at each grade level saw themselves as top pupils. This finding is most meaningful when examined in relationship to the mark point average of these particular Title I pupils. Those who saw themselves as good pupils had mark point averages that were higher than the Title I recipients who saw themselves as top pupils across every grade level except the twelfth grade.

While it is hard to render a direct interpretation of the meaning of this finding, one can surmise that the small percentage, representing a significant number of pupils, saw themselves quite unrealistically when not only compared with the state average but when compared to other Title I recipients. The discrepancy appears to be absent at the twelfth grade level where for the first time Title I pupils who see themselves as top pupils have a higher mark point average than those seeing themselves as good pupils. But, in every case it should be pointed out that Title I pupils are in fact lower in mark point average and distribute themselves quite differently than do the pupils in the state sample.

Average hours spent doing homework

The responses to the item "On the average how many hours each week do you spend doing work outside of school?" were analyzed and the results shown as Table III. The responses are shown by grade level on the left, with the possible response categories being none, 1-4, 5-9, 10-14, and 15 or more. To the right of the responses of the two groups appear the mean mark-point average and standard deviation for the Title I recipients and the statewide sample.

The grade seven response pattern was typical of the response pattern for the other grade levels. At the seventh grade level, Title I pupils spent less time doing work outside of school than the statewide total. In fact, 11.9% of Title I pupils as contrasted to 8.1% of the state as a whole spent no time doing homework outside of school. At the other end of the scale, ten or more hours of homework, we find 9% of the Title I pupils spending this amount of time while 9% of the state group also spent over ten hours or more doing homework outside of the school.

When one moves over to the right and examines the mean mark-point averages for the two groups, it becomes readily apparent that the more time spent doing homework, the better the mark-point average. It should be pointed out that the mean mark-point average for Title I students in no case exceeded the mean mark-point average for the state distribution as a whole.

TABLE III

ITEM: On the average how many hours each week do you spend doing homework outside of school?

Response	Number of Pupils		State N	%	Mean MPA		Standard Deviation	
	Title I N	State N			Title I	State	Title I	State
GRADE 7								
None	325	1248		8.1	1.37	2.07	0.77	0.78
1 - 4	1535	8316		53.7	1.51	2.24	0.75	0.76
5 - 9	621	4515		29.2	1.56	2.43	0.78	0.76
10 - 14	174	1077		6.9	1.58	2.50	0.79	0.79
15 or more	70	316		2.1	1.42	2.37	0.72	0.92
TOTAL	2725	15472						
GRADE 8								
None	392	1534		8.1	1.45	2.05	0.74	0.78
1 - 4	1912	9318		49.3	1.54	2.21	0.74	0.74
5 - 9	918	6025		31.9	1.67	2.43	0.76	0.74
10 - 14	227	1608		8.5	1.75	2.64	0.88	0.76
15 or more	54	421		2.2	1.66	2.68	1.02	0.85
TOTAL	3503	18906						
GRADE 9								
None	655	2731		9.3	1.63	2.02	0.65	0.73
1 - 4	2786	14119		47.9	1.69	2.20	0.65	0.73
5 - 9	1299	9096		30.9	1.83	2.43	0.66	0.73
10 - 14	342	2773		9.5	1.83	2.66	0.70	0.76
15 or more	77	699		2.4	1.90	2.76	0.84	0.83
TOTAL	5159	29418						

TABLE III (continued)

ITEM: On the average how many hours each week do you spend doing homework outside of school?

Response	Number of Pupils		%	State N	%	Mean MPA		Standard Deviation	
	Title I N	State N				Title I	State	Title I	State
GRADE 10									
None	511	2456	11.8	2456	8.9	1.51	1.93	0.62	0.72
1 - 4	2255	12106	51.9	12106	44.0	1.61	2.11	0.62	0.74
5 - 9	1217	8942	28.0	8942	32.5	1.75	2.37	0.65	0.75
10 - 14	284	3061	6.5	3061	11.2	1.98	2.67	0.69	0.76
15 or more	79	937	1.8	937	3.4	1.90	2.87	0.69	0.81
TOTAL	4346	27502		27502					
GRADE 11									
None	533	2503	14.1	2503	9.4	1.59	1.98	0.60	0.69
1 - 4	1857	10895	48.9	10895	41.1	1.69	2.16	0.62	0.71
5 - 9	1071	8803	28.2	8803	33.3	1.86	2.43	0.64	0.73
10 - 14	268	3281	7.1	3281	12.4	2.01	2.73	0.75	0.73
15 or more	63	996	1.7	996	3.8	2.06	2.89	0.88	0.75
TOTAL	3792	26478		26478					
GRADE 12									
None	462	2574	14.9	2574	10.7	1.82	2.10	0.63	0.75
1 - 4	1474	10079	47.8	10079	41.8	1.93	2.19	0.63	0.76
5 - 9	847	7540	27.5	7540	31.3	2.02	2.37	0.65	0.73
10 - 14	229	2932	7.5	2932	12.1	2.18	2.56	0.74	0.74
15 or more	69	990	2.3	990	4.1	2.26	2.58	0.79	0.72
TOTAL	3081	24115		24115					

Beginning with grade eight, and carried through grades nine, ten, eleven and twelve, was the tendency for Title I pupils to spend less time doing homework outside of school than their counterpart pupils in the statewide sample. For example, at grade 8, while 8% of the Title I respondents spent ten or more hours outside of school doing homework, 10.7% of the statewide distribution spent this amount of time. Moving to grade nine, the difference becomes one of 8.1% for the Title I group as contrasted to 11.9% for the state sample. At grade ten, while 8.3% of the Title I respondents spent ten or more hours working at homework, 13.6% of the state group responded in the category. At grade eleven the difference becomes greater. While 8.8% of the Title I respondents spent ten or more hours doing homework, 16.2% of the state sample spent a comparable amount of time. At grade twelve, 9.8% of the Title I pupils were involved for more than ten hours in homework while 16.2% of the state sample were involved to this extent.

In general, the figures shown in the table comparing the two groups on the question of the amount of time spent on homework outside of school showed at least three significant trends. First, Title I pupils were represented across all grade levels to a larger extent than the comparison group by the percentage responding under the category of not being involved at all in homework activity. Second, the number of Title I pupils represented by the two response categories - 10 -14 hours and 15 or

more hours spent doing homework - remained relatively constant and showed a slight rise as the grade level in school increased. On the other hand, for the state as a whole, with each successive grade level a corresponding increase in the percent of pupils who were involved in homework for ten or more hours per week appeared. Title I pupils tended to spend less time involved in homework activity than did their counterparts from the state group.

Third, whether or not one has the Title I pupil in mind as a referent, the relationship of the time spent doing homework outside of school to the mark-point average was positive. In other words, whether or not one was involved in Title I the following relationships held: (1) the amount of time spent doing homework was directly related to the marks received in school; (2) there was a disparity or discrepancy between mark-point average and involvement in homework activity which appeared to get larger as one progressed through the grade levels. When these findings are compared to the amount of time spent outside of school working for pay, the implications become still more meaningful.

Unpleasant experiences with other pupils

Pupil responses to the question "How many unpleasant experiences have you had with other students in the school?" for the two groups at grades 7, 8, 9, 10, 11 and 12 were also compared. Title I participants

ITEM: How many unpleasant experiences have you had with other students in the school?

TABLE IV

Response	Number of Pupils		%	Mean MPA		Standard Deviation		
	Title I N	State N		Title I	State	Title I	State	
GRADE 7								
A great many	178	550	6.5	3.5	1.16	1.74	0.68	0.75
Quite a few	304	1341	11.1	8.7	1.39	2.04	0.69	0.76
Not very many	936	4669	34.4	30.2	1.54	2.24	0.75	0.75
Very few	991	6788	36.4	43.9	1.57	2.41	0.78	0.77
None	314	2113	11.6	13.7	1.50	2.45	0.78	0.74
TOTAL	<u>2723</u>	<u>15461</u>						
GRADE 8								
A great many	177	544	5.1	2.9	1.36	1.80	0.72	0.76
Quite a few	377	1375	10.8	7.3	1.39	1.98	0.73	0.75
Not very many	1088	5113	31.4	27.1	1.53	2.19	0.72	0.75
Very few	1432	8935	40.4	47.3	1.64	2.41	0.79	0.74
None	430	2906	12.3	15.4	1.75	2.48	0.79	0.75
TOTAL	<u>3504</u>	<u>18873</u>						
GRADE 9								
A great many	178	599	3.5	2.1	1.30	1.72	0.61	0.71
Quite a few	441	1755	8.6	5.9	1.54	1.98	0.65	0.72
Not very many	1591	7649	30.5	26.0	1.70	2.17	0.63	0.73
Very few	2189	14232	42.5	48.5	1.79	2.39	0.66	0.74
None	755	5129	14.9	17.5	1.84	2.47	0.67	0.76
TOTAL	<u>5154</u>	<u>29364</u>						

TABLE IV (continued)

ITEM: How many unpleasant experiences have you had with other students in the school?

Response	Number of Pupils		N	%	Mean MPA		Standard Deviation		
	Title I	State			Title I	State	Title I	State	
GRADE 10									
A great many	126	476	1.7	1.37	1.76	0.63	0.75		
Quite a few	318	1290	4.7	1.45	1.90	0.60	0.75		
Not very many	1219	6242	22.8	1.62	2.09	0.61	0.75		
Very few	1961	13826	50.4	1.71	2.34	0.65	0.78		
None	719	5602	20.4	1.80	2.42	0.66	0.77		
TOTAL	4343	27436							
GRADE 11									
A great many	105	380	1.4	1.49	1.83	0.54	0.76		
Quite a few	231	1047	3.9	1.54	2.01	0.61	0.75		
Not very many	1037	5717	21.6	1.67	2.17	0.62	0.74		
Very few	1746	13760	52.2	1.80	2.39	0.65	0.75		
None	671	5538	20.9	1.85	2.44	0.66	0.73		
TOTAL	3790	26442							
GRADE 12									
A great many	64	339	1.4	1.69	2.10	0.61	0.75		
Quite a few	169	782	3.3	1.80	2.19	0.60	0.76		
Not very many	815	5052	21.0	1.90	2.37	0.61	0.73		
Very few	1517	13099	54.5	2.01	2.56	0.67	0.74		
None	516	4772	19.8	2.03	2.58	0.69	0.72		
TOTAL	3081	24044							

who responded to the question were tallied separately. A sample of statewide pupils who were not involved in Title I programs was again used for a comparison group. Table IV shows the responses of the two groups on the following five alternatives to the item: a great many, quite a few, not very many, very few, and none. Also included to the right of the response categories are the mean mark-point average for the Title I group and the state sample. The standard deviation for the two groups shown by response category is also indicated.

When examining the responses for grade seven, it becomes readily apparent that Title I pupils have many more unpleasant experiences with their fellow pupils than do those represented in the state sample. Under the category "a great many," 6.5% of the Title I pupils responded while only 3.5% of the state sample gave this reply. The two categories "quite a few" and "a great many" clearly show that the difference between the experiences of Title I pupils and the state comparison group becomes even more apparent. While 17.6% of the Title I participants in the seventh grade have had many experiences that were unpleasant, only 12.2% of the state group responded in this category.

Moving to the mark-point average, the relationship between the unpleasantness of school experiences and the mark-point average can be seen very readily. The less enjoyable school is, the more likely the

mark-point average will suffer. At grades 8, 9, 10, 11 and 12, the same general tendencies as were shown in grade seven held. In each case, Title I involved children had many more unpleasant experiences in school than did their counterparts. The significant shift that occurs across grade level between Title I pupils and those from the comparison groups occurs in the "very few" and "none" response categories.

For Title I pupils at grade seven, 11.6% report no unpleasant experience. The figure jumps to 12.3% at grade eight, 14.9% at grade nine, 16.6% at grade ten, 17.6% at grade eleven, 17.1% at grade twelve. In contrast, for the statewide sample the figures show an increase from grades seven, eight and nine but at grade ten, eleven and twelve the figure appears to be more constant and represents a little over 20% for grades ten and eleven, and slightly under 20% (19.8%) at grade twelve. Perhaps the best explanation of this finding also falls under selective retention.

From Table IV it should also be pointed out that across all grade levels there is a marked relationship between the mark-point average one achieves in school and the pleasantness of the experiences with other pupils. In general, the more pleasant the experiences with other students, the higher the mark-point average will be. This relationship holds for both Title I involved pupils and for the state sample.

Again on the positive side, it is interesting to note that over three-fourths of the pupils from both groups at all grade levels have not had very many unpleasant experiences with other pupils in their schools. In general, for both Title I pupils and for the state as a whole, school is a pleasant place. But, when unpleasant experiences do occur, the chances are that they will occur in significantly greater numbers to Title I pupils than to other pupils in the school.

Multiple Regression

A multiple regression analysis was performed on twenty-three variables for grades 8 and 9. The criterion variable in this analysis was the Mark-Point Average of the student. The idea of a multiple regression problem is to predict the criterion (Mark-Point Average) from the best linear combination of the contributions of the other available items of information. This particular program only retains information which assists in predicting the criterion. The following items of information were included:

1. Sex
2. ITBS - vocabulary score
3. ITBS - reading comprehension score
4. ITBS - language skills total score
5. ITBS - work-study skills total score
6. ITBS - arithmetic skills total score
7. Father's occupation
8. Mother's occupation
9. Hours per week mother works
10. Father's education
11. Mother's education
12. Hours per week work for pay
13. Hours per week work for no pay
14. Hours per week on homework outside of school
15. Unpleasant experiences
16. Attitude toward studying
17. How teachers view you
18. Expected grades for next year
19. Educational aspirations
20. Educational expectations
21. Own a car
22. How often drive car
23. Mark-Point Average

The program employed in this analysis consisted of a multiple regression with elimination. The program provides as output the correlations among the independent and criterion variables; the inverse of the correlation matrix for the independent variables; the beta weights for linear regression on the criterion variable; means and standard deviations of the independent and dependent variables; the capital B coefficients for a linear prediction equation; the multiple correlation coefficient; the multiple correlation squared coefficient; F test of departure of the multiple correlation from 0; and the t test for the significance of beta coefficients.

The program functions by sequentially selecting and eliminating the variables with the lowest beta values and recomputing the resulting correlation matrix and inverse until only significant beta values remain.

Grade 7

In the series of tables that follow, a summary of the significant features of the multiple regression with elimination program are presented. Table V, the summary for non-Title I pupils at the seventh grade level, shows the inter-correlations of six independent variables and Mark-Point Average, the seventh variable. The independent variables were sex, ITBS-reading, ITBS-language total, ITBS-arithmetic total, CardPac Item 24, "How do teacher view you," and CardPac Item 25, "Next year if you are in school (or a college) you will probably."

NON-TITLE I -- GRADE 7

Intercorrelations Among Retained Variables for
Predicting Mark-Point Averages

	1	2	3	4	5	6	7	M	S.D.
1. SEX		-.03	.22	-.04	-.03	.03	.12	1.53	0.50
2. ITBS-R			.67	.67	-.30	.43	.52	79.79	15.99
3. ITBS-LT				.68	-.32	.42	.56	79.45	16.85
4. ITBS-AT					-.35	.44	.55	80.15	13.53
5. CP-24						-.15	-.32	12.63	1.00
6. CP-25							.40	13.58	0.94
7. M.P.A.								2.61	1.00

Beta Values

$$Z_7 = .08Z_1 + .147Z_2 + .188Z_3 + .228Z_4 - .114Z_5 + .144Z_6$$

B - Values

$$X_7 = .161X_1 + .009X_2 + .011X_3 + .017X_4 - .114X_5 + .153X_6 - 1.329$$

$$R = 0.64175 \quad R\text{-SQ} = 0.41185$$

$$\text{Standard error of estimate} = 0.7692$$

F-test value for hypothesis of R-SQ equal to 0

$$F = 218.824$$

t-test value for Betas

1	2	3	4	5	6
4.19	5.51	6.56	8.31	-5.98	7.11

Degrees of freedom = 1875.

To the right of the variable matrix, the mean and standard deviation for each variable are shown. Below the correlation matrix two computations of beta weights are presented. The first presents the contribution of each variable to the criterion of Mark-Point Average when the variables are expressed as standard scores. Second, B values are shown for each of the variables in their raw score form. The last figure shown in the second computation is the constant necessary to balance the equation or the correction term.

Below the B values, the multiple correlation and the multiple correlation squared are presented along with the standard error of estimate for the multiple correlation. The F-test for the hypothesis that r square is equal to 0 and the t tests for significance of the weights are also presented in the table.

For non-Title I pupils the best combination of the twenty-two variables were the six listed above. Upon examining Table V, the multiple correlation for the six variables was $R = .642$. The unusual bits of information from this analysis were the two CardPac Items representing a pupil's understanding of how he was viewed by his teachers and his prediction of his success in school next year.

Grade 8

Table VI summarizes the significant variables in the multiple regression analysis for Title I pupils at the eighth grade level. Of the

TABLE VI
TITLE I -- GRADE 8

Intercorrelations Among Retained Variables for
Predicting Mark-Point Averages

	1	2	3	4	M	S.D.
1. ITBS-V		-.21	.29	.29	68.62	15.85
2. CP-24			-.44	-.26	13.04	0.65
3. CP-25				.30	12.88	0.75
4. M.P.A.					1.96	1.02

Beta Values

$$Z_4 = .211Z_1 - .136Z_2 + .176Z_3$$

B - Values

$$X_4 = .013X_1 - .212X_2 + .238X_3 + .767$$

$$R = 0.38479$$

$$R-SQ = 0.14806$$

Standard error of estimate = 0.9370

F-test value for hypothesis of R-SQ equal to 0

$$F = 31.167$$

t-test value for Betas

1	2	3
5.04	-3.05	3.89

Degrees of freedom = 538.

twenty-two possible variables, three were significant in terms of their contribution to the prediction of Mark-Point Average at the eighth grade level for Title I pupils.

The ITBS-verbal, CardPac Item 24, "How do teachers view you," and CardPac Item 25, "Next year if you are in school (or a college) you will probably," proved valuable in predicting Mark-Point Average. The multiple correlation for the group was $R = .385$. For Title I pupils, there were only three independent variables contributing to the best linear predictions of Mark-Point Average at the eighth grade level.

Table VII clearly shows the marked contrast between Title I and non-Title I pupils in terms of the ability of the regression model to predict Mark-Point Average from the best linear combination of variables. At the eighth grade level only three variables contributed significantly to the prediction of Mark-Point Average for Title I pupils while ten variables did so for the non-Title I group.

For non-Title I pupils the variables which contributed to the prediction of mark-point averages were:

sex, ITBS-reading, ITBS-language total, ITBS-arithmetic total, CardPac Item 3 - "Father's occupation," CardPac Item 5 - "Mother's work at present," CardPac Item 22 - "Unpleasant experiences with other students," CardPac Item 24 - "How do teachers view you," CardPac Item 25 - "If in school next year will probably," and CardPac Item 26 - Educational aspirations.

The multiple correlation for non-Title I pupils shown on Table VII was .609. On Table VI the multiple correlation for Title I pupils at the

TABLE VII

NON-TITLE I -- GRADE 8

Intercorrelations Among Retained Variables for
Predicting Mark-Point Averages

	1	2	3	4	5	6	7	8	9	10	11	M	S.D.
1. SEX		.00	.28	-.02	-.02	-.00	.10	-.03	.05	.01	.51	1.51	0.50
2. ITBS-R			.67	.68	.24	-.16	.11	-.44	.49	.46	.47	89.45	17.06
3. ITBS-LT				.67	.22	-.16	.14	-.43	.46	.42	.52	88.92	18.45
4. ITBS-AT					.20	-.15	.13	-.45	.47	.40	.48	89.60	15.77
5. CP-3						-.13	.05	-.15	.19	.25	.11	20.69	7.89
6. CP-5							-.06	.09	-.12	-.14	-.15	13.89	4.17
7. CP-22								-.17	.15	.14	.17	13.71	0.89
8. CP-24									-.37	-.34	-.40	12.54	0.84
9. CP-25										.43	.43	13.56	0.86
10. CP-26											.36	21.30	4.62
11. M.P.A.												2.58	1.02

Intercorrelations Among Retained Variables -- Grade 8 Non-Title I (cont.)

Beta Values

$$Z_{11} = .085Z_1 + .091Z_2 + .187Z_3 + .141Z_4 - .056Z_5 - .053Z_6 + .051Z_7 - \\ .127Z_8 + .141Z_9 + .076Z_{10}$$

B - Values

$$X_{11} = .174X_1 + .005X_2 + .01X_3 + .009X_4 - .007X_5 - .013X_6 + .059X_7 - \\ .155X_8 + .167X_9 + .017X_{10} - .992$$

$$R = 0.60913 \quad R-SQ = 0.37104$$

Standard error of estimate = 0.8126

F-test value for hypothesis of R-SQ equal to 0

$$F = 128.250$$

t-test value for Betas

1	2	3	4	5	6	7	8
4.50	3.45	6.70	5.38	-3.13	-3.03	2.95	-6.33
9	10						
6.77	3.74						

Degrees of freedom = 2174.

eighth grade level was .385. In terms of the overlap or commonality of independent variables, CardPac items 24 and 25 were included under both groups. In terms of "best fit" there were over three times the number of variables contributing to non-Title I prediction as contributed to prediction of Title I pupils' MPA at the eighth grade level.

Significantly, the overlapping items from the two groups were those in which the pupils themselves served as the source of information. At least at the eighth grade level, this finding would tend to confirm the oft-heard generalization that the most valid source of pupil information related to his success in school when success is expressed as a Mark-Point Average is the pupil's own estimation of future success.

Grade 9 ITBS

The multiple correlations and predictive equations summarized as Table VIII were for Title I pupils at the ninth grade level.

Here again the restricted range of significant contributing variables to predicting Mark-Point Average was shown. The multiple correlation for the group was .772. But, at this grade level, there were very few cases, the number being in the 70's. The appearance of CardPac Item 25, "If in school next year will probably," as a significant item for the group should be noted.

Iowa Tests of Educational Development

At the secondary level, the sub-tests of the Iowa Tests of Educational Development replaced the ITBS in the multiple regression analysis. While

TABLE VII
TITLE I -- GRADE 9

Intercorrelations Among Retained Variables for
Predicting Mark-Point Averages

	1	2	3	M	S. D.
1. TBS-WT		.04	.70	77.40	16.14
2. CP-25			.57	13.03	0.68
3. M.P.A.				2.01	0.65

Beta Values

$$Z_3 = .568Z_1 + .344Z_2$$

B - Values

$$X_3 = .023X_1 + .330X_2 - 2.520$$

$$R = 0.77231 \quad R\text{-SQ} = 0.59646$$

$$\text{Standard error of estimate} = 0.4148$$

F-test value for hypothesis of R-SQ equal to 0

$$F = 51.732$$

t-test value for Betas

1	2
6.86	4.16

Degrees of freedom = 70.

the Iowa Tests of Basic Skills contributed five variables, the ITED subtests furnished nine and expanded the number of independent variables in the secondary analysis to twenty-six. The twenty-seventh variable was again the criterion variable of Mark-Point Average. The following list presents the items employed:

1. Sex
2. ITED-Understanding of basic social concepts
3. ITED-Background in the natural sciences
4. ITED-Correctness and appropriateness of expression
5. ITED-Ability to do quantitative thinking
6. ITED-Ability to interpret reading materials in the social studies
7. ITED-Ability to interpret reading materials in the natural sciences
8. ITED-Ability to interpret literary materials
9. ITED-General vocabulary
10. ITED-Use of sources of information
11. Father's occupation
12. Mother's occupation
13. Hours per week mother works
14. Father's education
15. Mother's education
16. Hours per week work for pay
17. Hours per week work for no pay
18. Hours per week on homework outside of school
19. Unpleasant experiences
20. Attitude toward studying
21. How teachers view you
22. Expected grades for next year
23. Educational aspirations
24. Educational expectations
25. Own a car
26. How often drive car
27. Mark-Point Average

Grade 9 ITED

The five variables which contributed significantly to the prediction of Mark-Point Average of the twenty-six possible variables for non-Title I pupils at the secondary level were ITED-general vocabulary, ITED-use of sources of information, CardPac Item 24 - "How do teachers view you," CardPac Item 25 - "If in school next year will probably," and CardPac Item 26 which deals with the educational aspirations. The multiple correlation for the group was .548. See Table IX.

Grade 10

Turning to grade 10, Table X shows the six items of information or variables which contribute significantly to the prediction of Mark-Point Average for Title I pupils at this particular grade level. In order they were: ITED-correctness and appropriateness of expression, ITED-ability to do quantitative thinking, ITED-general vocabulary, and the same three items of CardPac information that were listed for non-Title I pupils on Table IX.

When these findings are compared to those for non-Title I pupils at the tenth grade level shown in Table XI, five of the eight variables that contributed significantly differed. The non-overlapping items on the second group were sex, ITED-background in natural sciences, ITED-ability to interpret reading material in the natural sciences, and ITED-use of sources of information. The same three CardPac items contributed to

NON-TITLE I -- GRADE 9

Intercorrelations Among Retained Variables for
Predicting Mark-Point Averages

	1	2	3	4	5	6	M	S. D.
1. ITED-8		.93	-.17	.11	.20	.12	17.40	11.45
2. ITED-9			-.23	.15	.22	.17	17.98	11.88
3. CP-24				-.42	-.41	-.51	12.56	0.72
4. CP-25					.33	.34	13.60	1.21
5. CP-26						.35	21.24	4.56
6. M. P. A.							2.59	1.02

Beta Values

$$Z_6 = -.172Z_1 + .197Z_2 - .387Z_3 + .118Z_4 + .144Z_5$$

B - Values

$$X_6 = -.015X_1 + .017X_2 - .550X_3 + .1X_4 + .032X_5 + 7.414$$

$$R = 0.54839 \quad R\text{-SQ} = 0.30073$$

$$\text{Standard error of estimate} = 0.8546$$

F-test value for hypothesis of R-SQ equal to 0

$$F = 227.937$$

t-test value for Betas

1	2	3	4	5
-3.99	4.52	-20.28	6.47	7.88

Degrees of freedom = 2650.

TITLE I -- GRADE 10

Intercorrelations Among Retained Variables for
Predicting Mark-Point Averages

	1	2	3	4	5	6	7	M	S. D.
1. ITED-3		.42	.51	-.18	.18	.30	.27	12.03	4.26
2. ITED-4			.40	-.20	.14	.29	.25	11.71	4.65
3. ITED-8				-.18	.15	.32	.26	11.78	4.33
4. CP-24					.38	-.08	-.19	13.14	1.09
5. CP-25						.30	.17	12.93	1.36
6. CP-26							.23	16.89	4.75
7. M.P.A.								1.89	1.07

Beta Values

$$Z_7 = .102Z_1 + .089Z_2 + .082Z_3 - .197Z_4 + .175Z_5 + .077Z_6$$

B-Values

$$X_7 = .026X_1 + .02X_2 + .02X_3 - .192X_4 + .137X_5 + .017X_6 + 1.427$$

$$R = 0.39193 \quad R\text{-SQ} = 0.15361$$

Standard error of estimate = 0.9845

F-test value for hypothesis of R-SQ equal to 0

$$F = 65.850$$

t-test value for Betas

1	2	3	4	5	6
4.19	3.84	3.41	-8.62	7.48	3.47

Degrees of freedom = 2177.

NON-TITLE I -- GRADE 10

Intercorrelations Among Retained Variables for
Predicting Mark-Point Averages

	1	2	3	4	5	6	7	8	9	M	S. D.
1. SEX		-.18	-.10	.08	.15	-.07	.08	-.03	.16	1.52	0.50
2. ITED-2			.63	.69	.63	-.45	.39	.45	.37	19.54	4.81
3. ITED-4				.65	.64	-.48	.42	.44	.39	17.42	5.52
4. ITED-6					.71	-.50	.43	.46	.42	18.23	6.03
5. ITED-9						-.47	.42	.45	.37	18.80	5.58
6. CP-24							-.47	-.43	-.44	12.60	0.76
7. CP-25								-.41	.39	13.56	0.95
8. CP-26									.34	21.10	4.55
9. M. P. A.										2.57	1.18

Beta Values

$$Z_9 = .182Z_1 + .134Z_2 + .118Z_3 + .096Z_4 - .079Z_5 - .203Z_6 + .14Z_7 + .08Z_8$$

B - Values

$$X_9 = .431X_1 + .033X_2 + .025X_3 + .019X_4 - .017X_5 - .314X_6 + .173X_7 + .021X_8 - 1.61$$

$$R = 0.55727$$

$$R-SQ = 0.31055$$

$$\text{Standard error of estimate} = 0.9795$$

F-test value for hypothesis of R-SQ equal to 0

$$F = 131.245$$

t-test value for Betas

1	2	3	4	5	6	7	8
9.44	4.88	4.55	3.34	-2.82	-9.34	6.73	3.84

$$\text{Degrees of freedom} = 2331.$$

the prediction for both Title I and non-Title I pupils at the tenth grade level.

In terms of contrast, the multiple correlation for the Title I group was .391 for the six variables while the non-Title I group had a multiple correlation of .557 for their eight variables.

This finding was consistent with other comparisons of multiple correlations for the Title I and non-Title I pupils. The usefulness of the linear model for predicting future Mark-Point Average appears to be greater for pupils not involved in Title I programs at the levels thus far investigated.

Grade 11

Table XII presents the seven variables of information retained by the elimination process from the original twenty-six variables in the prediction of Mark-Point Average at the eleventh grade level.

For Title I pupils sex, ITED-understanding of basic social concepts, ITED-ability to do quantitative thinking, ITED-ability to interpret reading materials in the natural sciences, and CardPac Items 24, 25 and 26, already described for grades 9 and 10, were the significant contributors. The multiple correlation for the Title I group at the eleventh grade level was .403.

When compared to the non-Title I pupils at grade 11 (Table XIII), it became apparent that again fewer variables are related to the criterion measure for Title I pupils than for non-Title I pupils.

TITLE I -- GRADE 11

Intercorrelations Among Retained Variables for
Predicting Mark-Point Averages

	1	2	3	4	5	6	7	8	M	S. D.
1. SEX		-.12	-.16	.00	-.08	.04	-.01	.12	1.47	0.50
2. ITED-1			.48	.53	-.20	.18	.38	.26	12.41	4.66
3. ITED-4				.48	-.20	.16	.31	.24	12.62	4.96
4. ITED-6					-.22	.19	.33	.27	12.62	5.18
5. CP-24						.15	-.15	-.21	13.12	0.88
6. CP-25							.36	.17	12.95	1.25
7. CP-26								.25	17.31	4.79
8. M.P.A.									1.98	1.20

Beta Values

$$Z_8 = .13Z_1 + .095Z_2 + .092Z_3 + .094Z_4 - .146Z_5 + .106Z_6 + .098Z_7$$

B - Values

$$X_8 = .311X_1 + .025X_2 + .022X_3 + .022X_4 - .199X_5 + .102X_6 + .025X_7 + .819$$

$$R = 0.40297 \quad R\text{-SQ} = 0.16238$$

Standard error of estimate = 1.0987

F-test value for hypothesis of R-SQ equal to 0

$$F = 58.658$$

t-test value for Betas

1	2	3	4	5	6	7
6.29	3.74	3.77	3.74	-6.79	4.77	4.24

Degrees of freedom = 2118.

TABLE XIII

NON-TITLE I -- GRADE 11

Intercorrelations Among Retained Variables for
Predicting Mark-Point Averages

	1	2	3	4	5	6	7	8	9	10	M	S.D.
1. SEX		-.12	-.24	.31	-.17	.11	-.06	.04	-.07	.18	1.52	0.50
2. ITED-1			.75	.57	.67	.73	-.37	.37	.52	.45	19.06	5.34
3. ITED-2				.49	.64	.63	-.31	.33	.48	.40	20.90	4.78
4. ITED-3					.58	.70	-.41	.37	.45	.51	18.79	4.56
5. ITED-4						.64	-.39	.36	.48	.48	19.31	6.06
6. ITED-9							-.38	.37	.50	.45	21.19	5.43
7. CP-24								-.19	-.33	-.42	12.57	1.05
8. CP-25									.30	.36	13.63	1.13
9. CP-26										.37	21.35	4.44
10. M.P.A.											2.56	0.97

Intercorrelations Among Retained Variables -- Grade 11 Non-Title I (cont.)

Beta Values

$$Z_{10} = .212Z_1 + .086Z_2 + .105Z_3 + .106Z_4 + .228Z_5 - .077Z_6 - .188Z_7 + .142Z_8 + .063Z_9$$

B - Values

$$X_{10} = .411X_1 + .016X_2 + .021X_3 + .022X_4 + .036X_5 - .014X_6 - .173X_7 + .121X_8 + .014X_9 + 2.554$$

$$R = 0.63256 \quad R\text{-SQ} = 0.40013$$

$$\text{Standard error of estimate} = 0.7498$$

F-test value for hypothesis of R-SQ equal to 0

$$F = 167.199$$

t-test value for Betas

1	2	3	4	5	6	7
10.23	2.93	3.91	3.88	8.91	-2.70	-10.17
8	9					
7.80	3.10					

Degrees of freedom = 2256.

For the non-Title I group the non-overlapping variables were ITED-background in natural sciences, ITED-the correctness and appropriateness of expression, and ITED-use of sources of information. While seven variables contributed to the Title I group, the contribution of nine variables was significant for the non-Title I group.

Again, the significance of the CardPac information related to pupil perceptions of how teachers view them, their prediction of success, and their educational aspirations were relevant for both groups in terms of predicting Mark-Point Average. The multiple correlation for the non-Title I group with nine variables was .633. This correlation was significantly higher than the multiple correlation for Title I pupils at the eleventh grade level.

Grade 12

At the twelfth grade level, six of the variables were retained in the prediction of Mark-Point Average for Title I involved pupils.

The ITED-understanding of basic social concepts, ITED-background in natural sciences, ITED-correctness and appropriateness of expression, ITED-use of sources of information, CardPac Item "Unpleasant experiences with other students," and the CardPac Item "How do teachers view you," contributed to the predicted equation. At the twelfth grade level the multiple correlation for the six significant variables was .386. See Table XIV.

TITLE I -- GRADE 12

Intercorrelations Among Retained Variables for
Predicting Mark-Point Averages

	1	2	3	4	5	6	7	M	S. D.
1. ITED-1		.66	.48	.66	.05	-.23	.27	14.54	4.96
2. ITED-2			.39	.56	.05	-.14	.16	15.76	5.16
3. ITED-3				.64	.07	-.27	.30	14.62	4.71
4. ITED-9					.00	-.27	.29	15.46	5.82
5. CP-22						.44	.05	13.79	1.68
6. CP-24							-.23	13.04	0.85
7. M. P. A.								9.22	1.38

Beta Values

$$Z_7 = .147Z_1 - .081Z_2 + .124Z_3 + .108Z_4 + .125Z_5 - .204Z_6$$

B-Values

$$X_7 = .041X_1 - .021X_2 + .036X_3 + .025X_4 + .102X_5 - .331X_6 + 3.911$$

$$R = 0.38581 \quad R\text{-SQ} = 0.14885$$

Standard error of estimate = 1.2706

F-test value for hypothesis of R-SQ equal to 0

$$F = 50.598$$

t-test value for Betas

1	2	3	4	5	6
4.37	-2.65	4.19	3.12	4.92	-7.69

Degrees of freedom = 1736.

Table XV shows the summary of relevant information when non-Title I twelfth grade pupil data were subjected to the linear regression model. The multiple correlation for non-Title I pupils at the twelfth grade level was .552.

In terms of the unique contributors to the non-Title I group equation or non-overlapping contributors on the non-Title I group, sex, ITED-ability to do quantitative thinking, ITED-ability to interpret reading materials in the natural sciences, CardPac Item 11, the "hours per week spent doing homework outside of school," and CardPac Item 23, "general attitude toward studying," occurred.

At the twelfth grade level the only common item of information that served as a contributing variable for both the Title I and non-Title I groups was ITED-correctness and appropriateness of expression.

Summary

When the comparisons of Title I and non-Title I pupils using the linear model of multiple regression were made, the most salient generalization was that no single set of items contributed across grade levels. The relationship between Mark-Point Averages and related variables is a multifarious one and does not lend itself to oversimplification.

The one outstanding contribution from these analyses was the consistent contribution of pupil self-descriptive information in the prediction problem. CardPac proved to be a significant source of information across

NON-TITLE I -- GRADE 12

Intercorrelations Among Retained Variables for
Predicting Mark-Point Averages

	1	2	3	4	5	6	7	M	S. D.
1. SEX		.34	-.15	.07	.21	-.14	.23	1.50	0.50
2. ITED-3			.63	.71	.24	-.26	.49	19.74	4.98
3. ITED-4				.72	.13	-.17	.40	20.33	6.55
4. ITED-6					.18	-.23	.45	21.33	6.52
5. CP-11						-.27	.23	12.66	1.10
6. CP-23							-.25	12.83	0.87
7. M.P.A.								2.68	0.99

Beta Values

$$Z_7 = .16Z_1 + .161Z_2 + .182Z_3 + .158Z_4 + .082Z_5 - .098Z_6$$

B - Values

$$X_7 = .316X_1 + .032X_2 + .027X_3 + .024X_4 + .074X_5 - .111X_6 + 1.001$$

$$R = 0.55158 \quad R\text{-SQ} = 0.30424$$

Standard error of estimate = 0.8224

F-test value for hypothesis of R-SQ equal to 0

$$F = 158.510$$

t-test value for Betas

1	2	3	4	5	6
7.26	5.24	6.18	5.34	4.29	-5.14

Degrees of freedom = 2175.

all grade levels. A pupil's perceptions of himself and how his teachers view him along with his attitudes toward studying and his aspirations for further education were closely tied with any prediction of success in an academic setting when the linear regression model was employed.

Table XVI shows the discriminant function means and standard deviations on the 18 selected variables for the three groups at the 10th grade level. Down the left hand column of the table the 18 variables are listed. Across the table the means and standard deviations for the three groups--non-Title I and Title I identified and Title I included--are presented.

The similarity between the means for the three groups on many of the variables becomes readily apparent upon examining the table. The most notable mean differences occurred on variable 3, the composite Iowa Testing Program mean score, variable 4, CardPac inventory item 3 "Father's Occupation", CardPac Item 26 "Educational Aspirations" and CardPac Item 27 "Educational expectations". While other variables were significantly different in terms of mean score those sited here were the most obvious differences noted.

Table XVII shows the discriminant vectors for the three group assignment categories at the 10th grade level. Across the bottom of the table the constant necessary for the balancing of the discriminant function equation is shown. In contrast to the more obvious difference in means noted on Table XVI, variables 16 and 17 in terms of their discriminant vector function showed little difference across the three groups. This was especially noticeable for variable 17--the educational expectations of the pupil--with the vector code being .53 for the non-Title I pupils, .53 for the Title I identified and .55 for the Title I included pupils.

TABLE XVI
 DISCRIMINANT FUNCTION MEANS AND STANDARD DEVIATIONS
 FOR 3 GROUPS -- GRADE 10

Variable	Non-Title I		Title I Identified		Title I Included	
	M	SD	M	SD	M	SD
1	1.50	0.50	1.47	0.50	1.43	0.50
2	2.39	0.73	1.72	0.61	1.68	0.63
3	17.72	5.50	11.73	3.81	10.93	3.92
4	6.12	3.73	4.97	3.43	4.68	3.51
5	4.00	2.61	3.60	2.18	3.56	2.19
6	2.69	2.19	2.87	2.28	2.97	2.38
7	5.60	2.56	5.07	2.64	5.05	2.65
8	5.85	2.31	5.32	2.35	5.30	2.34
9	2.35	1.51	2.60	1.65	2.71	1.73
10	2.77	1.59	2.78	1.63	2.94	1.72
11	2.55	0.92	2.40	0.87	2.34	0.85
12	3.87	0.84	3.67	0.94	3.65	0.95
13	2.90	0.77	3.03	0.75	3.05	0.78
14	2.66	0.73	3.16	0.68	3.20	0.67
15	3.46	0.82	2.86	0.80	2.80	0.78
16	7.05	2.65	5.06	2.50	4.79	2.47
17	6.46	2.72	4.77	2.55	4.61	2.43
18	2.86	1.83	2.70	1.87	2.85	1.83

TABLE XVII

DISCRIMINANT VECTORS FOR 3 GROUP ASSIGNMENT CATEGORIES
GRADE 10

<u>Variable</u>	<u>Non-Title I</u>	<u>Title I Identified</u>	<u>Title I Included</u>
1	5.82	5.90	5.83
2	5.76	5.22	5.37
3	0.50	0.30	0.25
4	0.16	0.14	0.13
5	0.07	0.07	0.07
6	0.52	0.50	0.52
7	0.38	0.38	0.39
8	0.62	0.60	0.60
9	1.46	1.46	1.49
10	1.25	1.26	1.32
11	2.48	2.60	2.56
12	4.85	4.79	4.81
13	6.37	6.31	6.31
14	16.09	16.09	16.06
15	8.14	8.08	8.06
16	-0.07	-0.10	-0.13
17	0.53	0.53	0.55
18	0.74	0.73	0.77
Constant	-83.12	-78.34	-78.16

When the pupils at the tenth grade level were reclassified using the discriminant function equations the correct and incorrect classifications are shown in the cross break titled Table XVIII.

Of the 8,930 pupils classified at the tenth grade level there were a total of 5,506 correct classifications. Upon examining the table, it becomes readily apparent that the program made the most errors in classification within groups 2 and 3, the Title I identified and Title I included groups. This type of error of classification would be expected after examining the information presented in Part 3 of this report. The similarity between the two groups was great.

Stated another way, the table showed that of the 4,761 pupils in the non-Title I group, 3,433 were correctly classified. Of the 11,053 Title I identified pupils, 478 were correctly classified. Of the 3,016 Title I included pupils, 1,595 were correctly classified. A much better prediction ratio would occur if groups 2 and 3 were collapsed into a single group. Nevertheless, the discriminant function equations did in fact, correctly classify pupils beyond chance expectation (significance level: greater than .01).

The discriminant function means and standard deviations at the 11th grade level are shown in Table XIX. Again, the variables of composite Iowa Testing Program mean score, CardPac questionnaire item 3, "Father's Occupation" and variables 16 and 17, CardPac items 26 and 27, "Educational Aspirations," and "Educational Expectations," showed the largest mean difference between the groups.

TABLE XVIII

TABLE OF CORRECT AND INCORRECT
DISCRIMINANT CLASSIFICATIONS--GRADE 10

True Group	Classified in Group			Totals
	1	2	3	
1	3433	740	588	4761
2	203	478	472	1153
3	<u>371</u>	<u>1050</u>	<u>1595</u>	<u>3016</u>
Totals	4007	2268	2655	8930

$\chi^2_{df=4} = 3166$ significant at .01 level

$t_2 = 62.3$ significant at .01 level

TABLE XIX

DISCRIMINANT FUNCTION MEANS AND STANDARD DEVIATIONS
FOR 3 GROUPS -- GRADE 11

Variable	Non-Title I		Title I Identified		Title I Included	
	M	SD	M	SD	M	SD
1	1.50	0.50	1.46	0.50	1.41	0.49
2	2.43	0.73	1.78	0.63	1.75	0.63
3	19.70	6.02	13.60	4.05	12.60	4.29
4	6.34	3.70	5.01	3.67	4.83	3.61
5	3.97	2.56	3.84	2.53	3.62	2.28
6	2.74	2.22	2.75	2.26	2.83	2.33
7	5.48	2.54	4.96	2.50	5.00	2.67
8	5.68	2.26	5.41	2.40	5.34	2.40
9	2.64	1.73	2.94	1.83	2.98	1.84
10	2.74	1.61	2.89	1.65	2.94	1.70
11	2.56	0.93	2.39	0.88	2.32	0.86
12	3.91	0.81	3.76	0.91	3.68	0.95
13	2.86	0.81	3.07	0.84	3.09	0.79
14	2.64	0.77	3.14	0.68	3.17	0.68
15	3.49	0.87	2.88	0.78	2.81	0.80
16	7.10	2.58	5.29	2.50	5.03	2.43
17	6.44	2.70	4.93	2.42	4.65	2.40
18	3.55	1.90	3.22	1.91	3.11	1.87

Table XX which showed the discriminant vectors for the three groups by assignment category again showed the relative weights assigned to each of the variables when classified in a multi-dimensional test space. The contribution of variable 4 "Father's Occupation" and variable 16 "Educational Aspirations" was the smallest of the 18 variables included.

When the discriminant vectors were applied to the groups for correct and incorrect discriminant function classifications, Table XXI resulted. In all, 8,100 pupils were classified at the 11th grade level. The ability of the discriminant function to predict class or group membership was significant beyond the 01 level.

Again it should be noted that the most frequent errors occurred in the classifications of group 1 and group 2. And this should be expected as the differences between the Title I identified and the Title I involved group were very slight and for practical purposes are not necessary.

The discriminant function means and standard deviation for the three groups at the twelfth grade level are shown in Table XXII. Variables 3, 4, 16 and 17 showed the largest discrepancy in mean score for the non-Title I and Title I identified pupils.

When the discriminant vectors for the three-group assignment categories were computed for the twelfth grade level, the results are shown as Table XXIII. Variables 16 and 17, while showing significant mean differences between the groups, again did not account for a large discrepancy in vector assignments. Variables 4 and 5 "Father's

TABLE XX
 DISCRIMINANT VECTORS FOR 3 GROUP ASSIGNMENT CATEGORIES
 GRADE 11

<u>Variable</u>	<u>Non-Title I</u>	<u>Title I Identified</u>	<u>Title I Included</u>
1	6.28	6.36	6.16
2	5.78	5.28	5.54
3	0.50	0.33	0.28
4	0.04	0.01	0.01
5	0.13	0.17	0.14
6	0.38	0.32	0.35
7	0.29	0.28	0.31
8	0.51	0.54	0.53
9	1.44	1.46	1.46
10	1.55	1.59	1.60
11	2.64	2.74	2.70
12	5.30	5.25	5.18
13	6.14	6.20	6.21
14	14.66	14.69	14.60
15	6.37	6.31	6.25
16	0.07	0.05	0.06
17	0.59	0.61	0.59
18	0.47	0.48	0.46
Constant	-79.80	-76.20	-74.82

TABLE XXI

TABLE OF CORRECT AND INCORRECT
DISCRIMINANT CLASSIFICATIONS--GRADE 11

True Group	Classified in Group			Totals
	1	2	3	
1	3207	760	489	4456
2	183	352	381	926
3	<u>397</u>	<u>939</u>	<u>1382</u>	<u>2718</u>
Totals	3787	2061	2252	8100

$$\chi^2_{df=4} = 2660 \quad \text{significant at .01 level}$$

$$t_2 = 34.6 \quad \text{significant at .01 level}$$

TABLE XXII

DISCRIMINANT FUNCTION MEANS AND STANDARD DEVIATIONS
FOR 3 GROUPS -- GRADE 12

Variable	Non-Title I		Title I Identified		Title I Included	
	M	SD	M	SD	M	SD
1	1.49	0.50	1.44	0.50	1.43	0.49
2	2.56	0.71	2.01	0.65	1.97	0.64
3	21.50	6.48	14.93	4.48	14.29	4.54
4	6.42	3.74	5.28	3.68	4.92	3.62
5	4.01	2.60	3.78	2.45	3.57	2.12
6	2.73	2.21	2.87	2.30	2.81	2.28
7	5.46	2.55	4.91	2.40	4.77	2.53
8	5.78	2.24	5.36	2.18	5.15	2.20
9	2.90	1.87	3.15	1.89	3.10	1.90
10	2.69	1.58	2.85	1.63	2.96	1.71
11	2.56	0.96	2.40	0.90	2.34	0.92
12	3.91	0.78	3.72	0.91	3.72	0.87
13	2.78	0.78	2.96	0.78	3.02	0.75
14	2.57	0.74	3.05	0.65	3.06	0.63
15	3.23	0.81	2.81	0.89	2.79	0.94
16	7.50	2.48	5.71	2.48	5.40	2.44
17	6.65	2.74	5.14	2.51	4.84	2.37
18	3.45	1.95	3.07	1.88	3.01	1.88

TABLE XXIII
 DISCRIMINANT VECTORS FOR 3 GROUP ASSIGNMENT CATEGORIES
 GRADE 12

<u>Variable</u>	<u>Non-Title I</u>	<u>Title I Identified</u>	<u>Title I Included</u>
1	6.65	6.51	6.45
2	8.05	7.82	7.79
3	0.58	0.40	0.39
4	0.09	0.08	0.06
5	0.08	0.09	0.07
6	0.44	0.43	0.43
7	0.42	0.40	0.41
8	0.70	0.71	0.69
9	1.72	1.70	1.67
10	1.79	1.83	1.86
11	3.24	3.36	3.33
12	6.00	5.88	5.90
13	7.38	7.38	7.45
14	16.22	16.32	16.20
15	4.61	4.63	4.68
16	0.49	0.44	0.41
17	0.48	0.49	0.49
18	0.39	0.41	0.41
Constant	-89.11	-85.17	-84.40

Occupation" had the smallest weightings in the vector computations for the twelfth grade group.

When the discriminant functions were computed and the correct and incorrect classifications tabulated for the twelfth grade level, Table XXIV shows the result. Again, the ability of this technique to classify pupils into their proper group was significant beyond the 01 level. Where incorrect classifications occurred, the trend was for them to occur between group 2 and group 3--the Title I identified and Title I involved groups.

The last of the discriminant function analyses was performed on the combined grades 10 through 12. In all, 24,135 pupils were handled in the combined analysis. Tables XXV, XXVI and XXVII show the results of these analyses. Table XXVII shows the discriminant function means and standard deviations for the combined 10 through 12 groups. The same trends that existed for the individual groups occurred; since they have already been discussed earlier, they are not reiterated here.

Table XXVI shows the discriminant vectors that a three group assignment categories on the combined grades 10 through 12. The similarity in vector weights between Table XXVI, Table XXIV and Table XX should be noted.

When the overall scheme was used to reclassify the total group, the classification distribution was again significantly different from chance beyond the 01 level. Of the total 13,482 non-Title I pupils, 9,631 were correctly classified. The misclassifications that did occur occurred between

TABLE XXIV

TABLE OF CORRECT AND INCORRECT
DISCRIMINANT CLASSIFICATIONS--GRADE 12

True Group	Classified in Group			Totals
	1	2	3	
1	3151	522	592	4265
2	174	305	363	842
3	<u>315</u>	<u>607</u>	<u>1076</u>	<u>1998</u>
Totals	3640	1434	2031	7105

$\chi^2_{df=4} = 2242$ significant at .01 level

$t_2 = 35.4$ significant at .01 level

TABLE XXV

DISCRIMINANT FUNCTION MEANS AND STANDARD DEVIATIONS
FOR 3 GROUPS -- GRADES 10-12 COMBINED

Variable	Non-Title I		Title I Identified		Title I Included	
	M	SD	M	SD	M	SD
1	1.50	0.50	1.46	0.50	1.43	0.50
2	2.46	0.73	1.79	0.61	1.77	0.65
3	19.68	6.18	13.35	4.22	12.49	4.45
4	6.33	3.67	5.07	3.64	4.79	3.57
5	3.99	2.58	3.77	2.42	3.57	2.17
6	2.75	2.22	2.81	2.27	2.87	2.33
7	5.62	2.60	5.00	2.53	4.97	2.63
8	5.81	2.30	5.39	2.32	5.30	2.36
9	2.65	1.74	2.90	1.79	2.91	1.82
10	2.66	1.57	2.83	1.62	2.93	1.71
11	2.58	0.94	2.42	0.90	2.35	0.87
12	3.91	0.81	3.72	0.92	3.69	0.93
13	2.84	0.79	3.03	0.79	3.07	0.79
14	2.62	0.75	3.13	0.66	3.15	0.67
15	3.41	0.84	2.85	0.85	2.80	0.82
16	7.25	2.57	5.35	2.50	5.09	2.49
17	6.54	2.72	4.96	2.50	4.74	2.43
18	3.29	1.93	3.00	1.89	3.00	1.87

TABLE XXVI

DISCRIMINANT VECTORS FOR 3 GROUP ASSIGNMENT CATEGORIES
 GRADES 10-12 COMBINED

<u>Variable</u>	<u>Non-Title I</u>	<u>Title I Identified</u>	<u>Title I Included</u>
1	5.98	6.05	5.93
2	6.41	5.85	6.04
3	0.51	0.35	0.31
4	0.11	0.08	0.07
5	0.12	0.15	0.12
6	0.45	0.40	0.42
7	0.38	0.36	0.37
8	0.60	0.61	0.59
9	1.54	1.55	1.54
10	1.48	1.53	1.57
11	2.88	3.00	2.95
12	5.38	5.32	5.30
13	6.48	6.47	6.50
14	15.51	15.53	15.45
15	6.36	6.25	6.24
16	0.17	0.14	0.13
17	0.52	0.53	0.53
18	0.56	0.58	0.59
Constant	-83.23	-79.07	-78.32

TABLE XXVII

TABLE OF CORRECT AND INCORRECT
DISCRIMINANT CLASSIFICATIONS--GRADES 10-12 COMBINED

True Group	Classified in Group			Totals
	1	2	3	
1	9631	2111	1740	13482
2	561	1064	1296	2921
3	<u>1180</u>	<u>2418</u>	<u>4134</u>	<u>7732</u>
Totals	11372	5593	7170	24135

$\chi^2_{df=4} = 12,627$ significant at .01 level

$t_2 = 91.4$ significant at .01 level

groups 2 and 3 for the most part and errors of this type should be taken rather lightly as the real problem is that of predicting membership in group 1 versus group 2 and 3 combined. Stated another way the program would have correctly classified 8,917 of the 10,653 pupils whose true group membership was 2 or 3.

PART V
SUMMARY

After reading the contents of this report, several of the more meaningful generalizations may have become obscured. This summary is presented in the hopes that their recapitulation will be useful to the reader.

In Part I, the distribution of Title I monies to the various SMSA levels within the states was shown. There, the first indication of the rural nature of the state became apparent. Still, in terms of involvement, over 95% of the eligible districts participated in the Title I programs. This was certainly a tribute to the State Department of Public Instruction's efforts in initiating the program.

The distribution of grant monies to LEA's and the ratio of administrative personnel to teaching and other specialized professional staff, to say the least, presented a favorable picture. The salaries paid to Title I staff members at all levels were consistent with those paid to teachers in similar work throughout the state. The professional workers employed in Title I activities were at a minimum comparable in training and age to those found elsewhere in the state. It was possible to implement a program of this scope without sacrificing quality of staff or salary structure within the state.

Perhaps the most significant shortcoming of the initial programs was their lack of comparable involvement at the preschool and early

elementary levels. It is expected that a significant shift in the composition of the pupil population toward more earlier involvement will occur during the second year of operation.

In Part II of the report, the objectives that were stated by the LEA's for their specific projects demonstrated the preponderance of reading type objectives--or, if you will, reading remediation projects during the initial year of Title I. The expectation for the second year, and, in fact, the commitment for the State Department of Public Instruction for the second year, is toward a better mix of projects.

The preponderance of reading type projects on the one hand may reflect the rather short period of project preparation before project involvement during this first year of operation. Then again, it may also reflect the most pressing need in our communities. Indeed, it is common knowledge that reading retardation accompanies a disadvantaged position in our educational society. Still, knowing the composition of educational objectives and the distribution of educational objectives across SMSA levels and within grade levels provides the first benchmark in determining the future needs within the state and the direction of the state mission for future program planning.

In the third part of the report, the make-up of the Title I pupil population in terms of aspirations, attitudes and achievement, was presented along with the background and training characteristics of the teaching and administrative staffs of the Title I effort. For comparison

purposes, figures were presented which represented the "non-disadvantaged" segment of our educational community to bring into striking relief the discrepancy, or academic lag that existed on all measured facets for Title I children.

Title I pupil achievement was lower, their aspirations were lower, their expectations were lower, their attendance was poorer, and their achievement level was less. When this information presented is taken as a whole, one could indeed say that during the first year of Title I operation educators did identify and treat under remedial programs the majority of those children who were identified as "educationally deprived."

In the fourth section of the report the more significant items of information were presented in juxtaposition with other information. The idea there was to attempt to find those first clues, those first steps, toward the interrelationships between educational segments and the outcome, i. e., the target population, the educationally disadvantaged pupil.

The results of the multiple regression and discriminant function analysis clearly demonstrated the prediction problems and the classification problems that exist when the range of ability as an input variable and the range of the criterion (Mark Point Average) is restricted for a group. The complete analysis of this information in the final report, it is expected, will indicate the changes in "what goes with what" as a pupil progresses through our educational system.

Finally, an interim report of this nature, because of the restrictions of time, leaves out many of the inprocess or as yet, incomplete analyses. For example, a separate appendix (Appendix D) is presented with this report which shows graphically the relationships across grade level for two achievement levels and the selected background characteristics of occupational and educational level of the parents and the aspirational level of the child.

The curriculum impact of Title I, when curriculum change was stated as a project objective during the first year, was such that of 307 districts serving as a base rate, 3.87 curriculum changes occurred in the 1965-66 school year. For the Title I curriculum projects, the 60 projects stating curriculum change as an objective averaged 6.06 changes. Truly, a significant difference in curriculum change.

It is hoped that this report has been viewed as an indication of the scope and direction of the final report due in July of 1968.